

## SPECIFICATIONS

PARAMETERS	VALUES	UNITS
RATED INPUT POWER	0.2	W
MAX INPUT POWER	0.4	W
IMPEDANCE	8 ± 15%	OHM
OUTPUT SPL @ 1W/0.5M (AT 0.8, 1.0, 1.2, 1.5 kHz)	90 ± 3	dBa
DISTORTION (MAX.)	5%	-
RESONANT FREQUENCY	550 ± 20%	Hz
FREQUENCY RANGE	550 ~ 4500	Hz
HOUSING MATERIAL	METAL	-
CONE MATERIAL	PAPER	-
MAGNET MATERIAL	Nd-Fe-B	-
OPERATING TEMPERATURE	-20 ~ +60	°C
WEIGHT	31	grams

THIS DOCUMENT CONTAINS DATA PROPRIETARY TO PROJECTS UNLIMITED, INC. ANY USE OR REPRODUCTION, IN ANY FORM, WITHOUT PRIOR WRITTEN PERMISSION OF PROJECTS UNLIMITED, INC. IS PROHIBITED.  
©2003, Projects Unlimited Inc.

## REVISION HISTORY

LTR	DESCRIPTION	DATE	APPROVED
-	RELEASED FROM ENGINEERING	5/8/2006	
A	REVISED TO INVENTOR 3-D DRAWING TEMPLATE	6/18/2008	B.R.

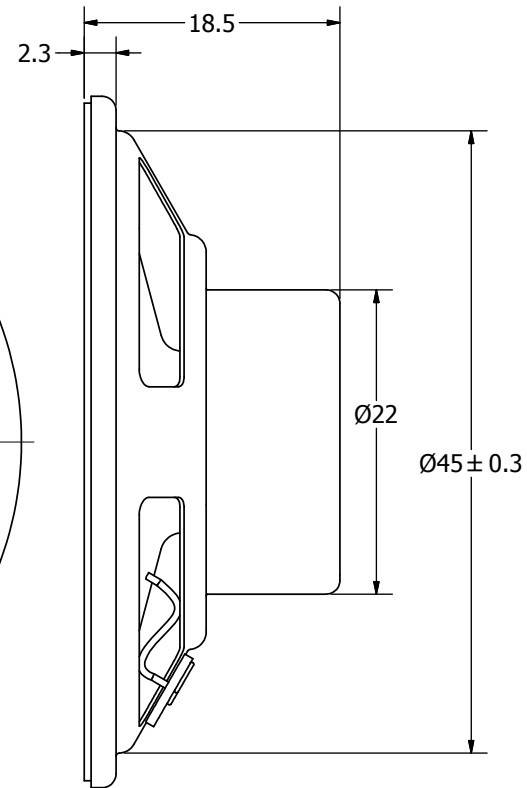
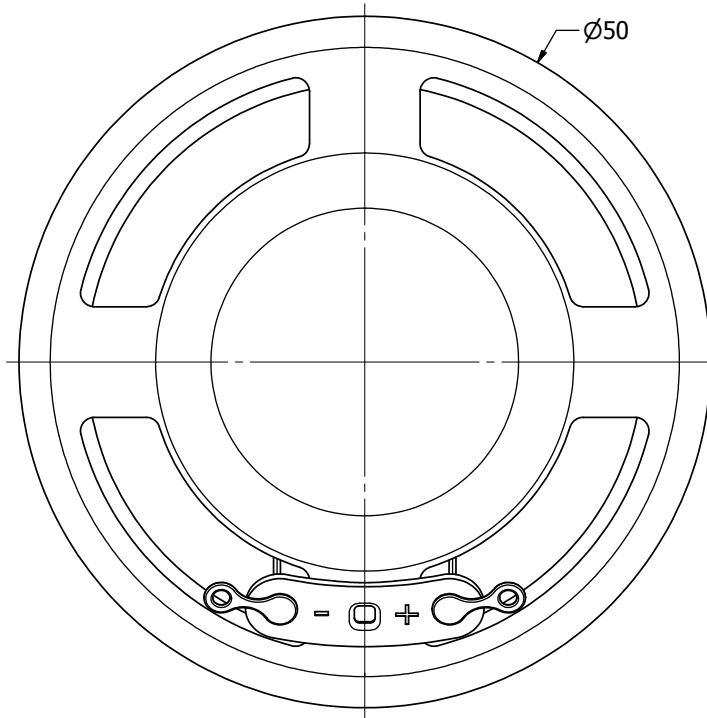

### NOTES:

1. ALL DIMENSIONS ARE IN MILLIMETERS.
2. SPECIFICATIONS SUBJECT TO CHANGE OR WITHDRAWAL WITHOUT NOTICE.
3. THIS PART IS RoHS 2002/95/EC COMPLIANT.

UNLESS OTHERWISE SPECIFIED: DIMENSIONS ARE IN MILLIMETERS, TOLERANCES ARE ±0.5 AND ANGLES ARE ±3°.	SIZE <b>A3</b>	Designed by	Date	Checked by	Date	Approved by	Date	Drawn Date
		J.D.	5/5/2006	E.P.	5/5/2006	B.R.	5/5/2006	6/18/2008
AS05008PR-2-R.idw						<b>AS05008PR-2-R</b>		
						Speaker		
					-	1 / 1		