



actual size

SMD Quartz Crystal · J49SML

- 2 pad version, 11.5 x 4.8 mm
- low cost SMD type
- reflow soldering temperature: 260 °C max.
- package height 3.0 mm max.



RoHS compliant



Pb free



REACH compliant



Conflict mineral free

GENERAL DATA

TYPE	J49SML
frequency range	4.0 MHz
	8.0 MHz
	12.0 MHz
	16.0 MHz
	20.0 MHz
	24.0 MHz
frequency tolerance at 25 °C	±30 ppm
load capacitance C_L	12 pF / 18 pF / 30 pF
shunt capacitance C_0	< 5 pF
storage temperature	-40 °C ~ +125 °C
drive level max.	500 µW (100 µW recommended)
aging	< ±5 ppm first year

ESR (SERIES RESISTANCE RS)

frequency in MHz	vibration mode	ESR max. in Ω	ESR typ. in Ω
4.0 MHz	fund. - AT	80	60
8.0 MHz	fund. - AT	50	25
12.0 MHz	fund. - AT	35	15
16.0 MHz	fund. - AT	30	10
20.0 MHz	fund. - AT	30	10
24.0 MHz	fund. - AT	30	10
25.0 MHz	fund. - AT	30	10

FREQUENCY STABILITY VS. TEMPERATURE

Stability code	G ±30 ppm
----------------	---------------------

LOAD CAPACITANCE CODES

12 pF : A
18 pF : F
30 pF : P

FREQUENCY TOLERANCE

Frequency tolerance code	G ±30 ppm
--------------------------	---------------------

OPERATING TEMPERATURE

Operating temperature code	K -40°C - +85°C
----------------------------	---------------------------

DIMENSIONS

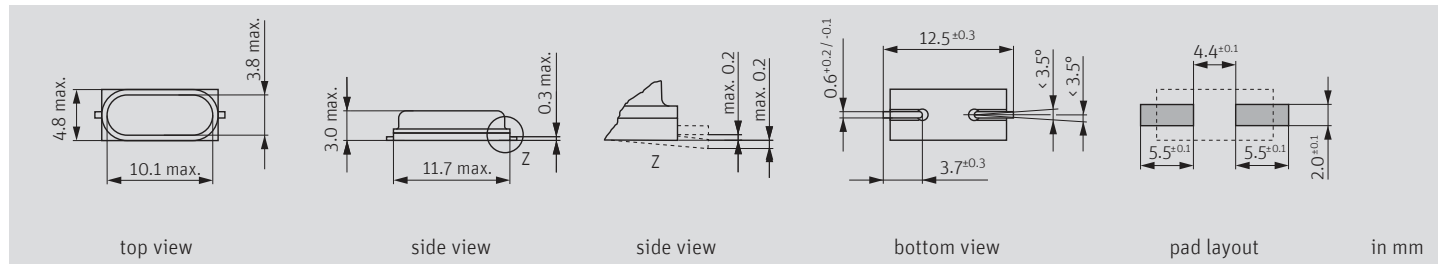

ORDER INFORMATION

J49SML-A-G-G-K-4M0	J49SML-P-G-G-K-12M0	J49SML-F-G-G-K-24M0
J49SML-F-G-G-K-4M0	J49SML-A-G-G-K-16M0	J49SML-P-G-G-K-24M0
J49SML-P-G-G-K-4M0	J49SML-F-G-G-K-16M0	J49SML-A-G-G-K-25M0
J49SML-A-G-G-K-8M0	J49SML-P-G-G-K-16M0	J49SML-F-G-G-K-25M0
J49SML-F-G-G-K-8M0	J49SML-A-G-G-K-20M0	J49SML-P-G-G-K-25M0
J49SML-P-G-G-K-8M0	J49SML-F-G-G-K-20M0	
J49SML-A-G-G-K-12M0	J49SML-P-G-G-K-20M0	
J49SML-F-G-G-K-12M0	J49SML-A-G-G-K-24M0	

Ordering example: J49SML-A-G-G-K-4M0 J49SML, 12pF Load Capacitance, 30ppm Freq tolerance, 30ppm Freq stability, -40-85 operating temp, 4MHz



SMD Quartz Crystal · J49SML

TAPING SPECIFICATION

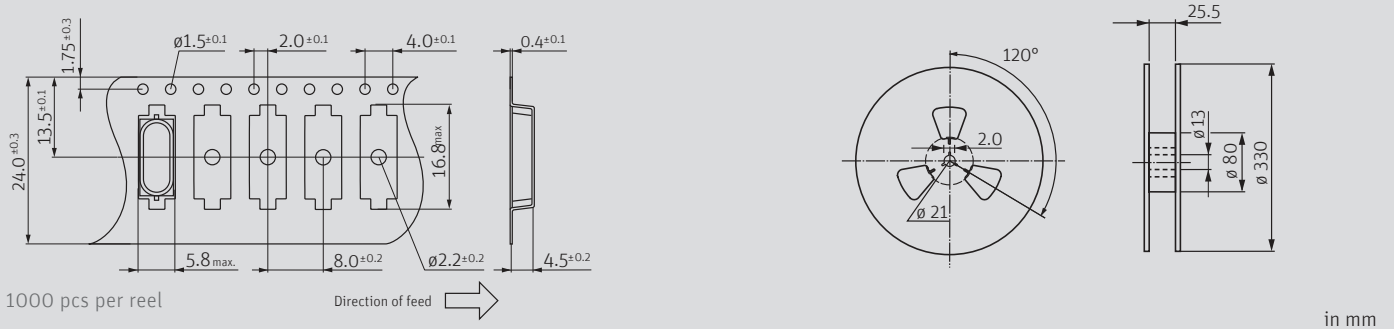

REFLOW SOLDERING PROFILE

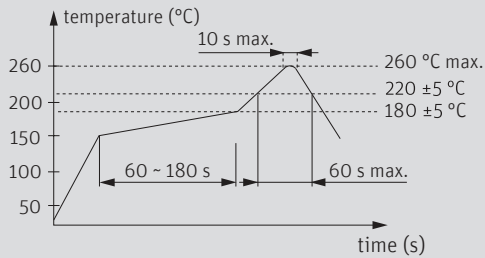

note: parts are also suitable for soldering systems with lead (Pb) content

MARKING

frequency with load capacitance code
company code / date code / internal code

	Jan.	Feb.	Mar.	Apr.	May	Jun.	Jul.	Aug.	Sep.	Oct.	Nov.	Dec.
2019	a	b	c	d	e	f	g	h	j	k	l	m
2020	n	p	q	r	s	t	u	v	w	x	y	z
2021	A	B	C	D	E	F	G	H	J	K	L	M
2022	N	P	Q	R	S	T	U	V	W	X	Y	Z