

ARM[®] Cortex[®]-M
32-bit Microcontroller

NuMicro[®] Family
NuTiny-SDK-NUC123
User Manual

The information described in this document is the exclusive intellectual property of Nuvoton Technology Corporation and shall not be reproduced without permission from Nuvoton.

Nuvoton is providing this document only for reference purposes of NuMicro microcontroller based system design. Nuvoton assumes no responsibility for errors or omissions.

All data and specifications are subject to change without notice.

For additional information or questions, please contact: Nuvoton Technology Corporation.

www.nuvoton.com

Table of Contents

1 OVERVIEW 4

2 NUTINY-SDK-NUC123 INTRODUCTION..... 5

2.1 NuTiny -SDK-NUC123 Jumper Description 6

2.1.1 Power Setting 6

2.1.2 Debug Connector 6

2.1.3 USB Connector 6

2.1.4 Extended Connector 6

2.1.5 Reset Button..... 6

2.1.6 Power Connector 6

2.1.7 Virtual COM Port Function Switch 7

2.2 Pin Assignment for Extended Connector 8

2.3 NuTiny-SDK-NUC123 PCB Placement 10

3 How to Start NuTiny-SDK-NUC123 on the Keil μ Vision[®] IDE 11

3.1 Keil uVision[®] IDE Software Download and Install 11

3.2 Nuvoton Nu-Link Driver Download and Install 11

3.3 Hardware Setup..... 11

3.4 Example Program..... 12

4 How to Start NuTiny-SDK-NUC123 on the IAR Embedded Workbench 13

4.1 IAR Embedded Workbench Software Download and Install 13

4.2 Nuvoton Nu-Link Driver Download and Install 13

4.3 Hardware Setup..... 13

4.4 Example Program..... 14

5 Starting to Use Nu-Link-Me 3.0 VCOM Function..... 15

5.1 Downloading and Installing VCOM Driver 15

5.2 VCOM Mode Setting on NuTiny-SDK-NUC123..... 16

5.3 Setup on the Development Tool..... 16

5.3.1 Check the Using UART on the Keil μ Vision[®] IDE..... 16

5.3.2 Check the Target Device and Debug Setting 17

5.3.3 Build and Download Code to NuTiny-SDK-NUC123..... 19

5.3.4 Open the Serial Port Terminal 19

5.3.5 Reset Chip 19

6 NuTiny-SDK-NUC123 Schematic 21

6.1 NuTiny-EVB-NUC123 Schematic 21

6.2 GPIO for 100 pin Schematic22

6.3 SDK Circuit Schematic.....23

6.4 Nu-Link-Me V3.0 Schematic24

7 REVISION HISTORY 25

1 OVERVIEW

NuTiny-SDK-NUC123 is the specific development tool for NuMicro® NUC123 series. Users can use NuTiny-SDK-NUC123 to develop and verify the application program easily.

NuTiny-SDK-NUC123 includes two portions. One is NuTiny-EVB-NUC123 and the other is Nu-Link-Me. NuTiny-EVB-NUC123 is the evaluation board and Nu-Link-Me is its Debug Adaptor. Thus, users do not need other additional ICE or debug equipments.

2 NUTINY-SDK-NUC123 INTRODUCTION

NuTiny-SDK-NUC123 uses the NUC123SD4AN0 as the target microcontroller. Figure 2-1 NuTiny-SDK-NUC123 (PCB Board) Figure 2-1 is NuTiny-SDK-NUC123 for NUC123 series, the left portion is called NuTiny-EVB-NUC123 and the right portion is Debug Adaptor called Nu-Link-Me.

NuTiny-EVB-NUC123 is similar to other development boards. Users can use it to develop and verify applications to emulate the real behavior. The on board chip covers NUC123 series features. The NuTiny-EVB-NUC123 can be a real system controller to design users' target systems.

Nu-Link-Me is a Debug Adaptor. The Nu-Link-Me Debug Adaptor connects your PC's USB port to your target system (via Serial Wired Debug Port) and allows you to program and debug embedded programs on the target hardware. The Nu-Link-Me V3.0 also supports VCOM function, which gives users more flexibility when debug. To use Nu-Link-Me Debug adaptor with IAR or Keil, please refer to "Nuvoton NuMicro® IAR ICE driver user manual" or Nuvoton NuMicro® Keil ICE driver user manual" in detail. These two documents will be stored in the local hard disk when the user installs each driver. To use Nu-Link-Me 3.0 VCOM function, please refer to Chapter 5.

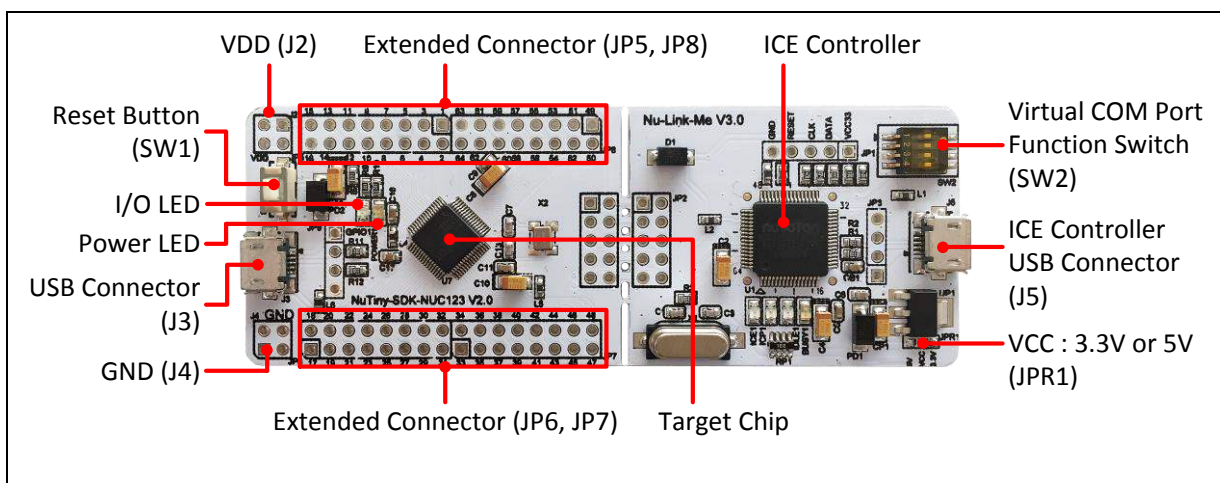

Figure 2-1 NuTiny-SDK-NUC123 (PCB Board)

2.1 NuTiny -SDK-NUC123 Jumper Description

2.1.1 Power Setting

- J2: V_{DD} Voltage connector in NuTiny-EVB-NUC123
- J3: USB port in NuTiny-EVB-NUC123
- J5: USB port in Nu-Link-Me
- JPR1: Select 5.0V or 3.3V for system power

Model	JPR1	J2 V_{DD}	J3 USB Port	J5 ICE USB Port	MCU Voltage
Model 1	Select 3.3V (Default)	DC 3.3V Output	X	Connect to PC	DC 3.3V
Model 2	Select 5.0V	DC 5.0V Output	X	Connect to PC	DC 5.0V
Model 3	Select 3.3V or 5.0V	DC 5.0V Output	Connect to PC	Connect to PC	DC 5.0V
Model 4*	X	DC 5.0V Output	Connect to PC	X	DC 5.0V
Model 5	Select 3.3V or 5.0V	DC 2.5V ~ 5.0V Input	X	Connect to PC	Voltage by J2 Input
Model 6*	X	DC 2.5V ~ 5.0V Input	X	X	Voltage by J2 Input

X: Unused.

Note*: Ned to separate NuTiny-EVB-NUC123 and Nu-Link-Me.

2.1.2 Debug Connector

- JP4: Connector in target board (NuTiny-EVB-NUC123) for connecting with Nuvoton ICE adaptor (Nu-Link-Me)
- JP2: Connector in ICE adaptor (Nu-Link-Me) for connecting with a target board (NuTiny-EVB-NUC123)

2.1.3 USB Connector

- J5: Micro USB Connector in NuTiny-EVB-NUC123 for application use
- J1: Micro USB Connector in Nu-Link-Me connected to a PC USB port

2.1.4 Extended Connector

- JP5, JP6, JP7, and JP8: Show all chip pins in NuTiny-EVB-NUC123

2.1.5 Reset Button

- SW1: Reset button in NuTiny-EVB-NUC123

2.1.6 Power Connector

- J2: V_{DD} connector in NuTiny-EVB-NUC123
- J4: GND connector in NuTiny-EVB-NUC123

2.1.7 Virtual COM Port Function Switch

- **SW2:** Switch SW2 on/off before power on to enable/disable VCOM function. SW2 connects pin 21(PB.0/RXD) and pin 22(PB.1/TXD) in NuTiny-EVB-NUC123 with pin 22(PB.1/TXD) and pin 21(PB.0/RXD) in Nuvoton ICE adaptor (Nu-Link-Me V3.0). SW2 connects pin 30(VCOM) in Nuvoton ICE adaptor (Nu-Link-Me V3.0) to GND to enable VCOM function.

Switch Pin Number	Disable VCOM Mode	Enable VCOM Mode
1	Off	On
2	Off	On
3	Off	On
4	Off	On

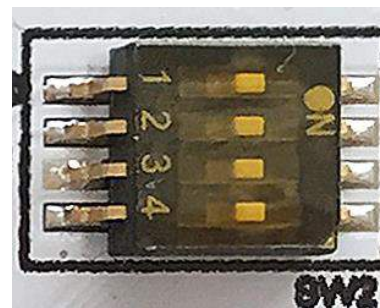

X: Unused.

2.2 Pin Assignment for Extended Connector

NuTiny-EVB-NUC123 provides NUC123SD4AN0 on board and the extended connector for LQFP100-pin. Table 2-1 is the pin assignment for NUC123SD4AN0.

Pin No	Pin Name	Pin No	Pin Name
01	PB.14/INT0	51	VSS
02	PB.13	52	PC.13/MOSI11/CLKO/PWM3
03	PB.12/SPISS10/CLKO	53	PC.12/MISO11/I2SMCLK/PWM2
04	PA.11/I2C1SCL/SPICLK1/MOSI20	54	PC.11/MOSI10
05	PA.10/I2C1SDA/MISO10/MISO20	55	PC.10/MISO10
06	PD.8/MOSI10	56	VDD
07	PD.9	57	PC.9/SPICLK1
08	PD.10/CLKO	58	PC.8/SPISS10
09	PD.11/INT1	59	PA.15/PWM3/CLKO/I2SMCLK
10	PB.4/RXD1/SPISS20/SPISS11	60	VSS
11	PB.5/TXD1/SPICLK2	61	PA.14/PWM2
12	PB.6/RTS1/MOSI20	62	PA.13/PWM1
13	PB.7/CTS1/MISO20	63	PA.12/PWM0
14	LDO	64	ICE_DAT
15	VDD	65	ICE_CLK
16	VSS	66	AVDD
17	VBUS	67	PD.0/SPISS20/ADC0
18	VDD33	68	PD.1/SPISS01/SPICLK2/ADC1
19	D-	69	PD.2/MISO01/MISO20/ADC2
20	D+	70	PD.3/MOSI01/MOSI20/ADC3
21	PB.0/RXD0	71	PD.4/MISO21/ADC4
22	PB.1/TXD0	72	PD.5/MOSI21/ADC5
23	PB.2/RTS0/T2EX	73	PB.15/INT1/T0EX
24	PB.3/CTS0/T3EX	74	PF.0/XT1_OUT
25	PC.5/MOSI01/TXD0	75	PF.1/XT1_IN
26	PC.4/MISO01/RXD0	76	/RESET
27	PC.3/MOSI00/I2SDO	77	VSS
28	PC.2/MISO00/I2SDI	78	VDD
29	PC.1/SPICLK0/I2SBCLK	79	PF.2/PS2DAT/I2C0SDA/ADC6

30	PC.0/SPISS00/I2SLRCLK	80	PF.3/PS2CLK/I2C0SCL/ADC7
31	PB.10/TM2/SPISS01	81	PVSS
32	PB.9/TM1/SPISS11	82	PB.8/TM0

Table 2-1 Pin Assignment for NUC123

2.3 NuTiny-SDK-NUC123 PCB Placement

Users can refer to Figure 2-2 for the NuTiny-SDK-NUC123 PCB placement.

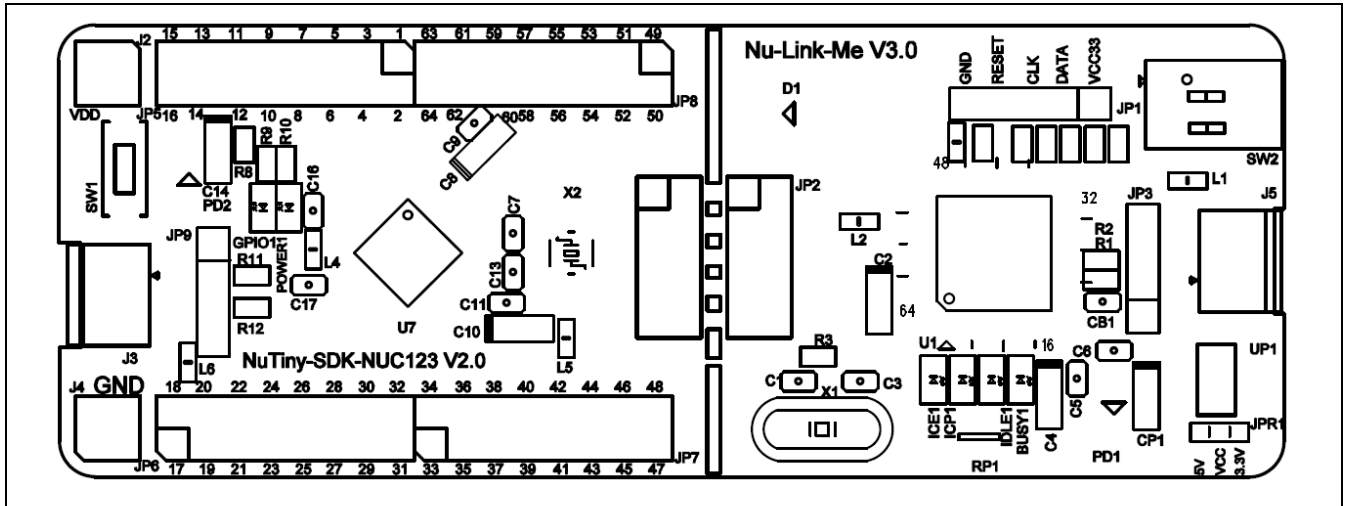

Figure 2-2 NuTiny-SDK-NUC123 PCB Placement

3 HOW TO START NUTINY-SDK-NUC123 ON THE KEIL MVISION® IDE

3.1 Keil uVision® IDE Software Download and Install

Please visit the Keil company website (<http://www.keil.com>) to download the Keil μ Vision® IDE and install the RVMDK.

3.2 Nuvoton Nu-Link Driver Download and Install

Please visit the Nuvoton company NuMicro® website (<http://www.nuvoton.com/NuMicro>) to download “NuMicro® Keil μ Vision® IDE driver” file. When the Nu-Link driver has been well downloaded, please unzip the file and execute the “Nu-Link_Keil_Driver.exe” to install the driver.

3.3 Hardware Setup

The hardware setup is shown as Figure 3-1.



Figure 3-1 NuTiny-SDK-NUC123 Hardware Setup

3.4 Example Program

This example demonstrates the ease of downloading and debugging an application on a NuTiny-SDK-NUC123 board. It can be found on Figure 3-2 list directory and downloaded from Nuvoton NuMicro® website.

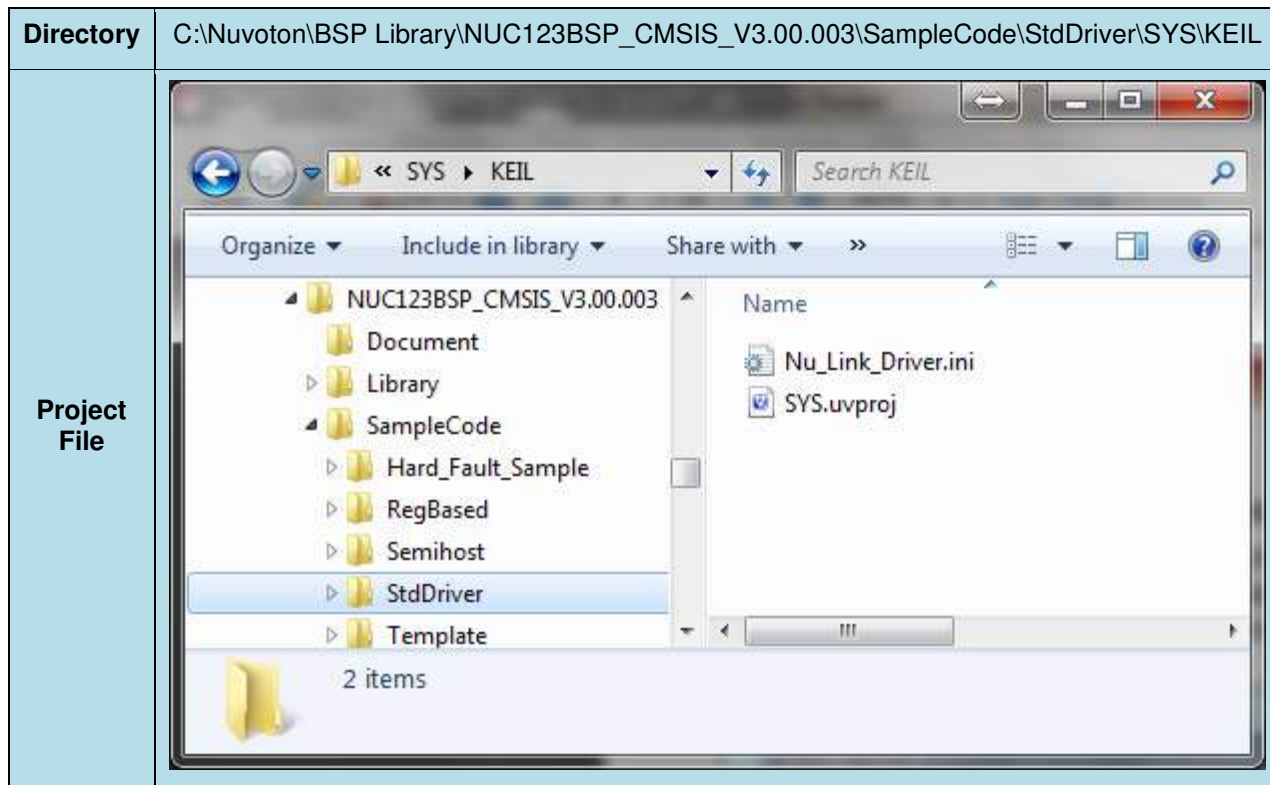









Figure 3-2 Example Directory

To use this example:

This sample code runs some functions about system manager controller and clock controller, and will show messages by Uart. Users can see the messages by following the steps of Chapter 5.

-  **Start µVision®**
- **Project-Open**
Open the SYS.uvproj project file
-  **Project - Build**
Compile and link the SYS application
-  **Flash – Download**
Program the application code into on-chip Flash ROM
-  **Start debug mode**
Using the debugger commands, you may:
 - ◆  Review variables in the watch window
 - ◆  Single step through code
 - ◆  Reset the device
 - ◆  Run the application

4 HOW TO START NUTINY-SDK-NUC123 ON THE IAR EMBEDDED WORKBENCH

4.1 IAR Embedded Workbench Software Download and Install

Please connect to IAR company website (<http://www.iar.com>) to download the IAR Embedded Workbench and install the EWARM.

4.2 Nuvoton Nu-Link Driver Download and Install

Please visit the Nuvoton company NuMicro[®] website (<http://www.nuvoton.com/NuMicro>) to download the “NuMicro[®] IAR EWARM Driver” file. When the Nu-Link driver has been well downloaded, please unzip the file and execute the “Nu-Link_Keil_Driver.exe” to install the driver.

4.3 Hardware Setup

The hardware setup is shown as Figure 4-1.

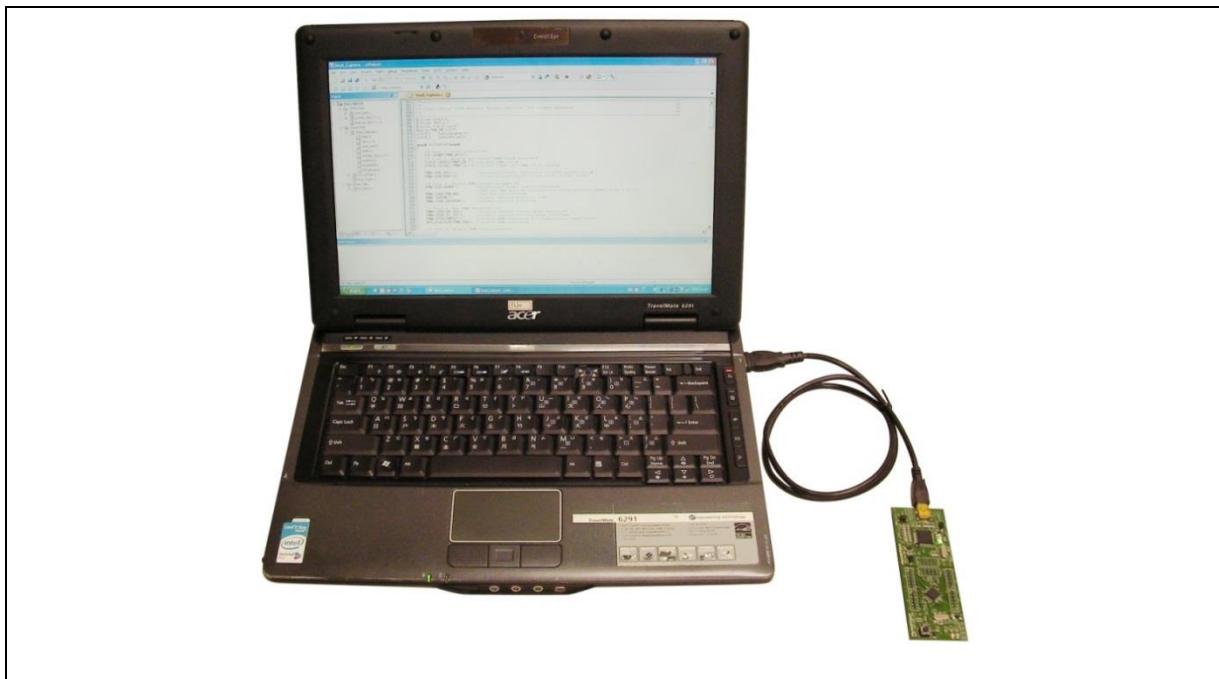

Figure 4-1 NuTiny-SDK-NUC123 Hardware Setup

4.4 Example Program

This example demonstrates the ease of downloading and debugging an application on a NuTiny-SDK-NUC123 board. It can be found on Figure 4-2 list directory and downloaded from Nuvoton NuMicro® website.

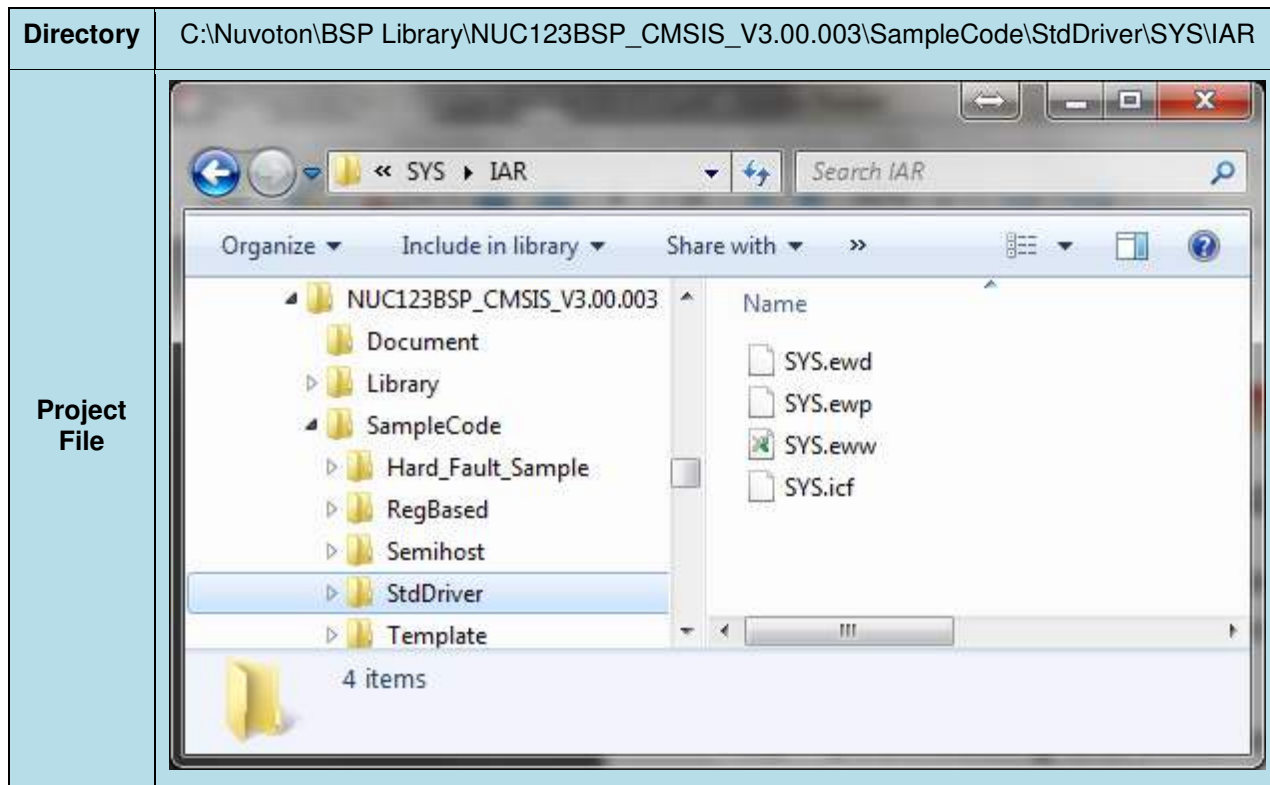

Figure 4-2 Example Directory

To use this example:

This sample code runs some functions about system manager controller and clock controller, and will show messages by Uart. Users can see the messages by following the steps of Chapter 5.

- Start IAR Embedded Workbench
- Project – Download and Debug
Program the application code into on-chip Flash ROM
- File-Open-Workspace
Open the SYS.eww workspace file
- Single step through code
- Reset the device
- Project - Make
Compile and link the SYS application
- Run the application

5 STARTING TO USE NU-LINK-ME 3.0 VCOM FUNCTION

5.1 Downloading and Installing VCOM Driver

Please connect to Nuvoton NuMicro® website (<http://www.nuvoton.com/NuMicro>) to download the “NuMicro® ICP Programming Tool” file. After the ICP Programming Tool driver is downloaded, please unzip the file and execute the “ICP Programming Tool.exe”. Simply follow the installation and optional steps to install ICP Programming Tool and Nu-Link USB Driver, which included VCOM driver.

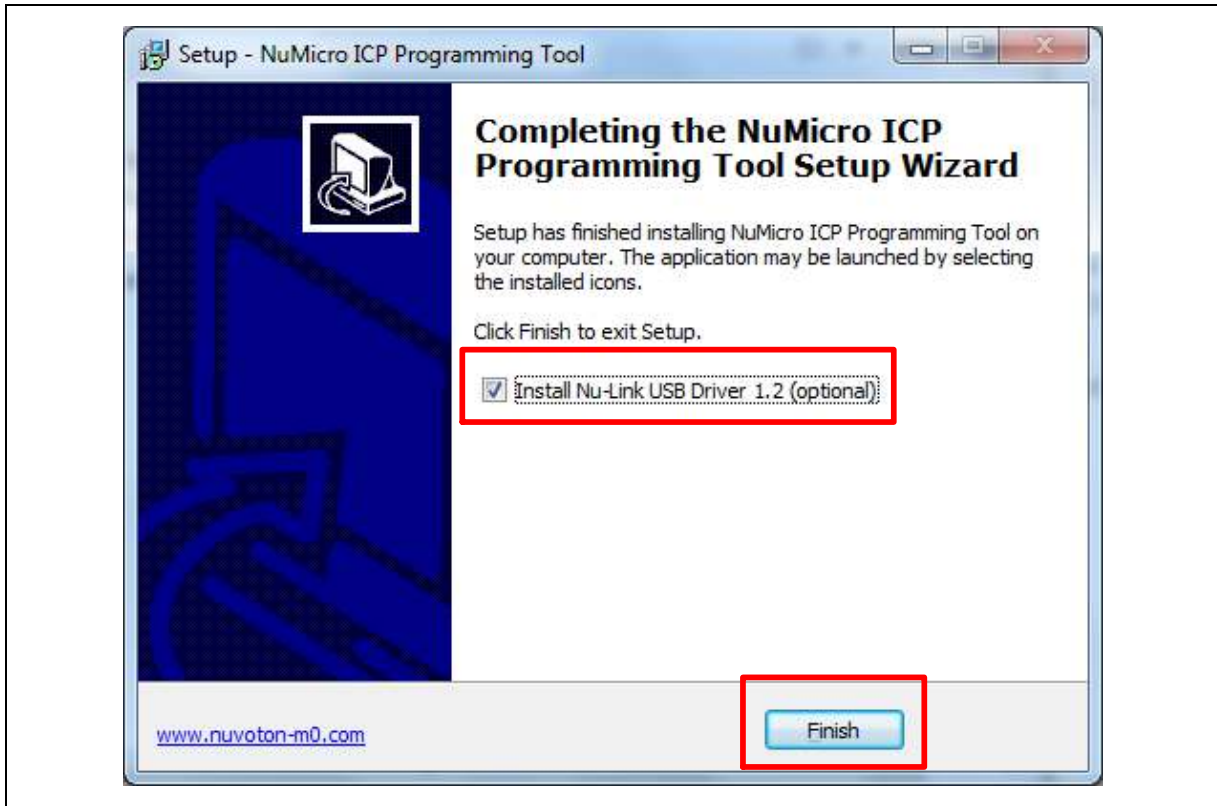

Figure 5-1 Optional Step after ICP Programming Tool Installation

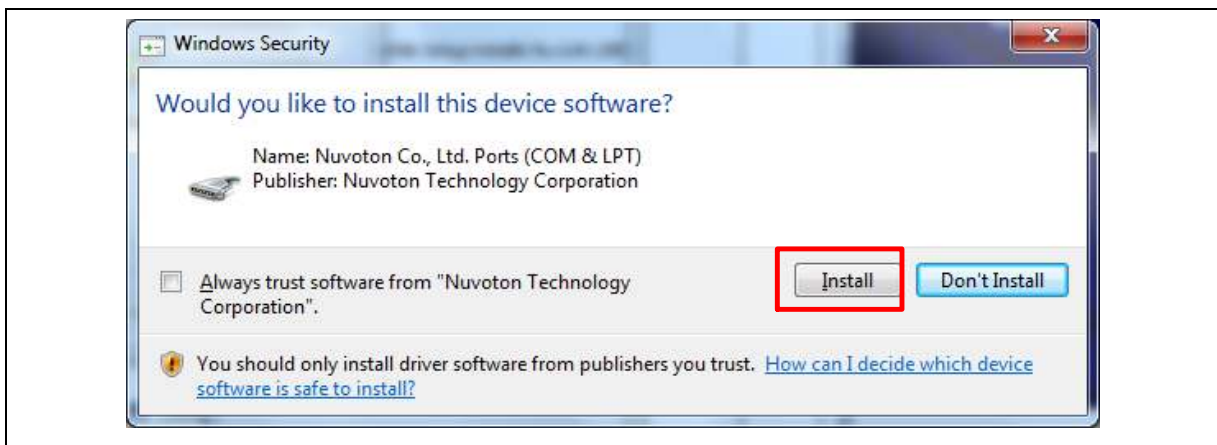

Figure 5-2 Install Nuvoton COM&LPT Driver

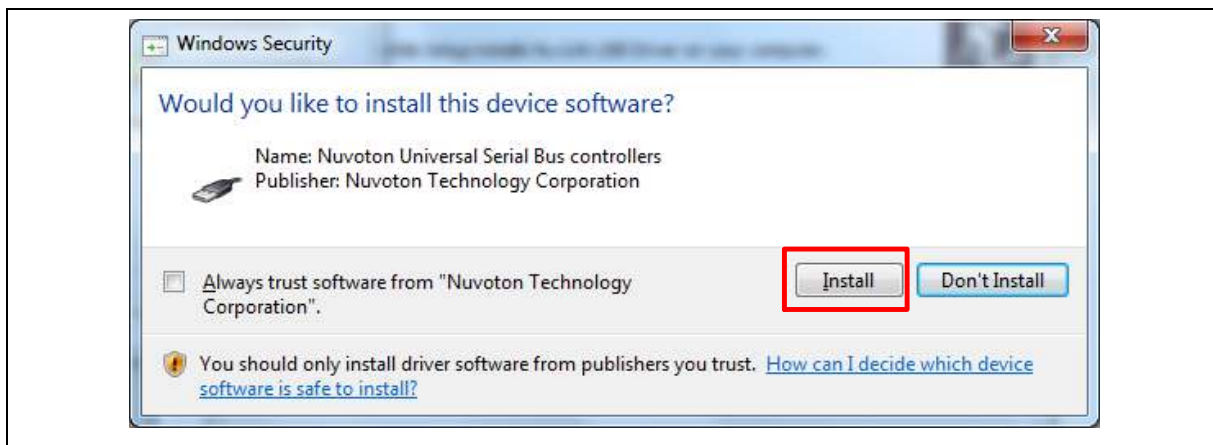

Figure 5-3 Install Nuvoton Universal Serial Bus Controllers

5.2 VCOM Mode Setting on NuTiny-SDK-NUC123

Before the NuTiny-SDK-NUC123 is connected to the PC, please enable SW2 VCOM function by switching on SW2. The NuTiny-EVB-NUC123 transmits through UART0 to VCOM to send out data. Switch SW2 off when using UART0 function without VCOM function.

After connected USB port in Nu-Link-Me to the PC, user can find a "Nuvoton Virtual Com Port" from Device Manager as Figure 5-4.

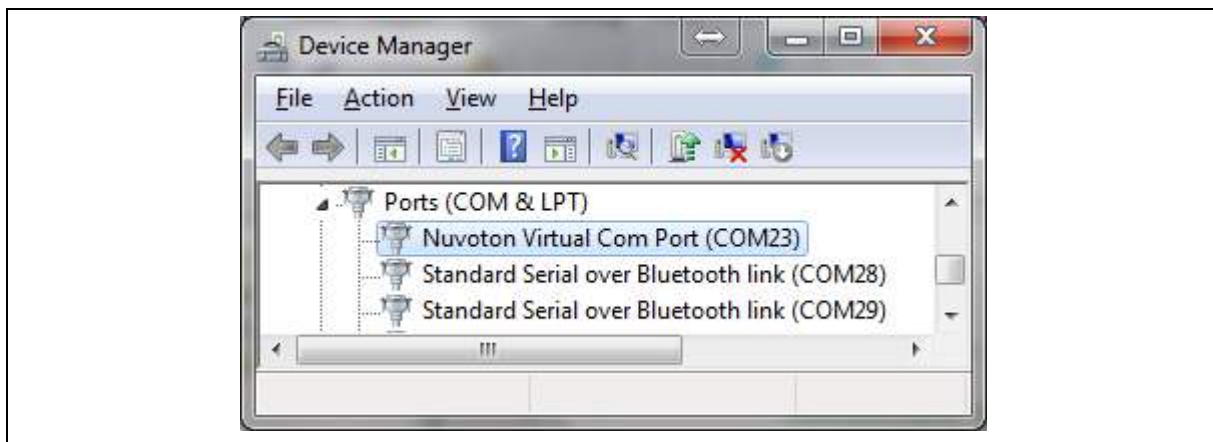

Figure 5-4 Nuvoton Virtual Com Port

5.3 Setup on the Development Tool

The example is demonstrated on the Keil μ Vision[®] IDE.

5.3.1 Check the Using UART on the Keil μ Vision[®] IDE

Please open the project and find system_NUC123.h (which can be found in \\NUC123BSP_CMSIS_V3.00.003\Library\Device\Nuvoton\NUC123\Include) to check the using UART in DEBUG_PORT. The setting has to be the same as the using UART in the NuTiny-EVB-NUC123.

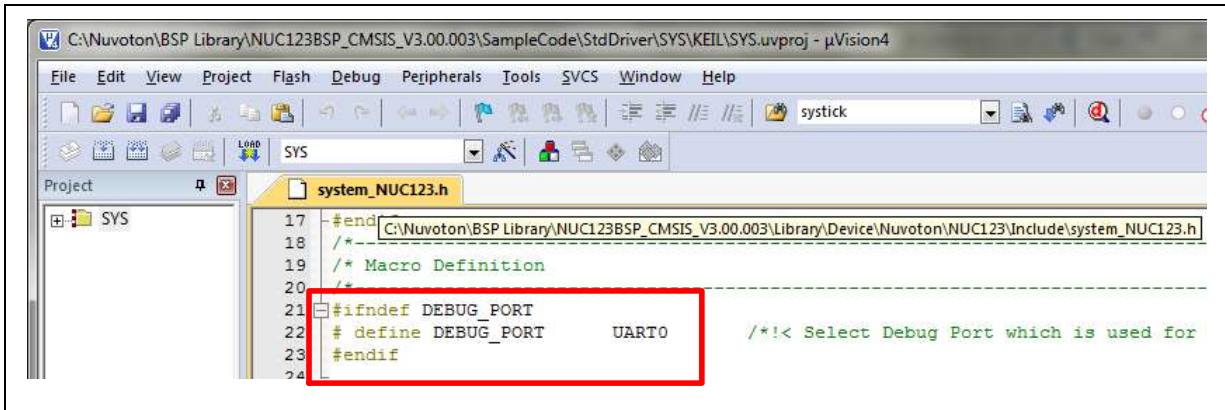
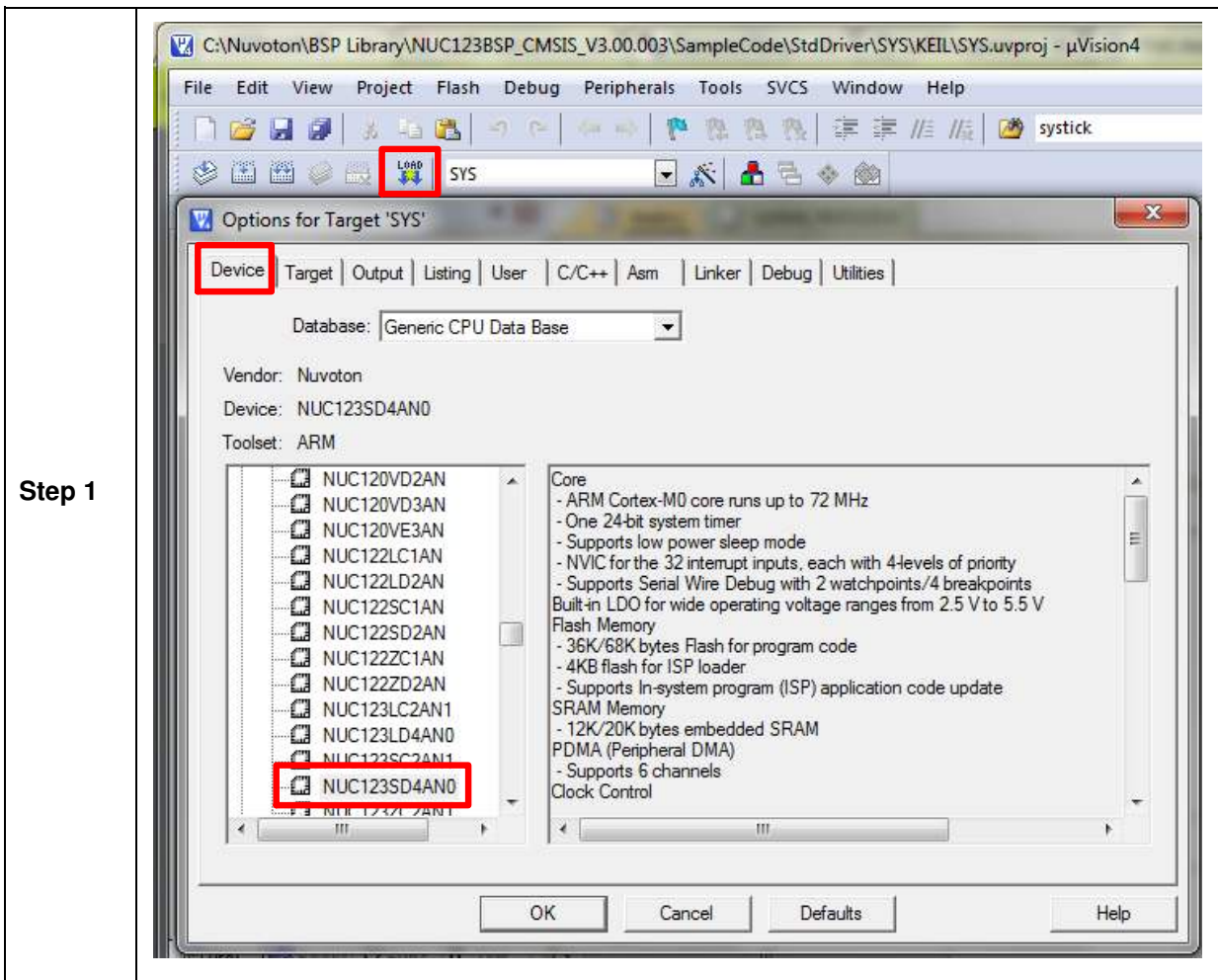

Figure 5-5 The Using UART on Keil μVision® IDE

5.3.2 Check the Target Device and Debug Setting

The target device has to be the same as the setting in Debug. Please click “Target Option” to open the Option windows, and find the setting in “Device”, “Debug”, and “Utilities” page. Please follow the steps below to check the setting.



Step 1

Step 2

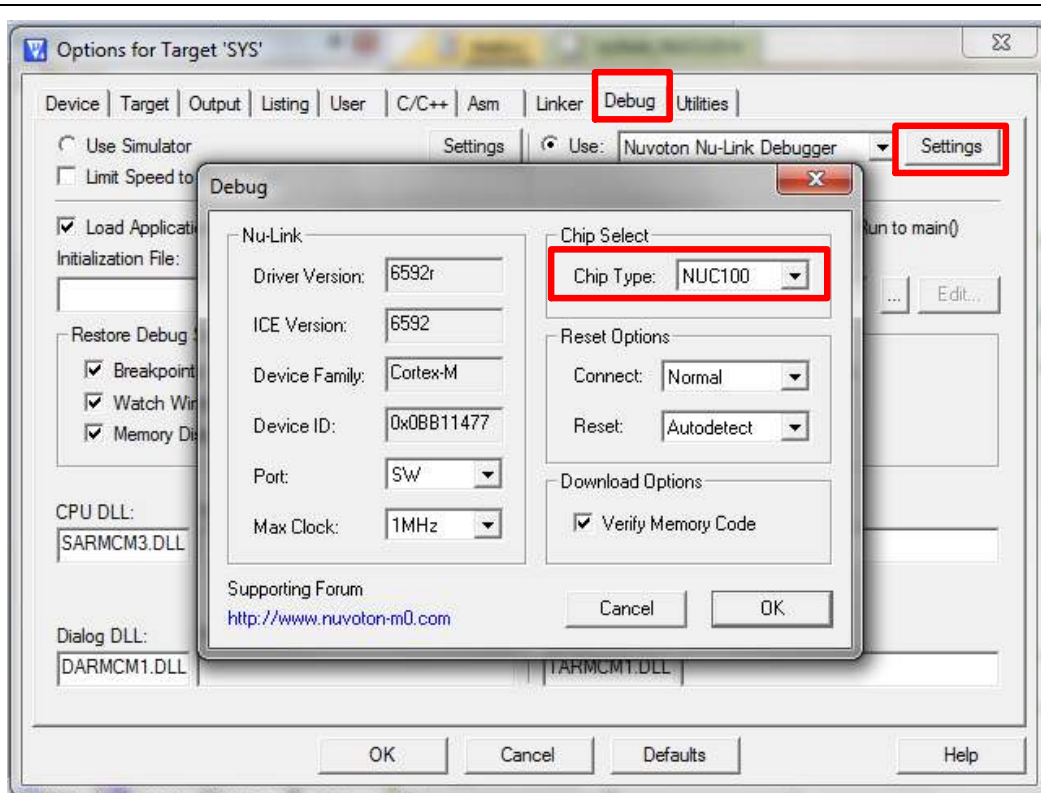

Step 3

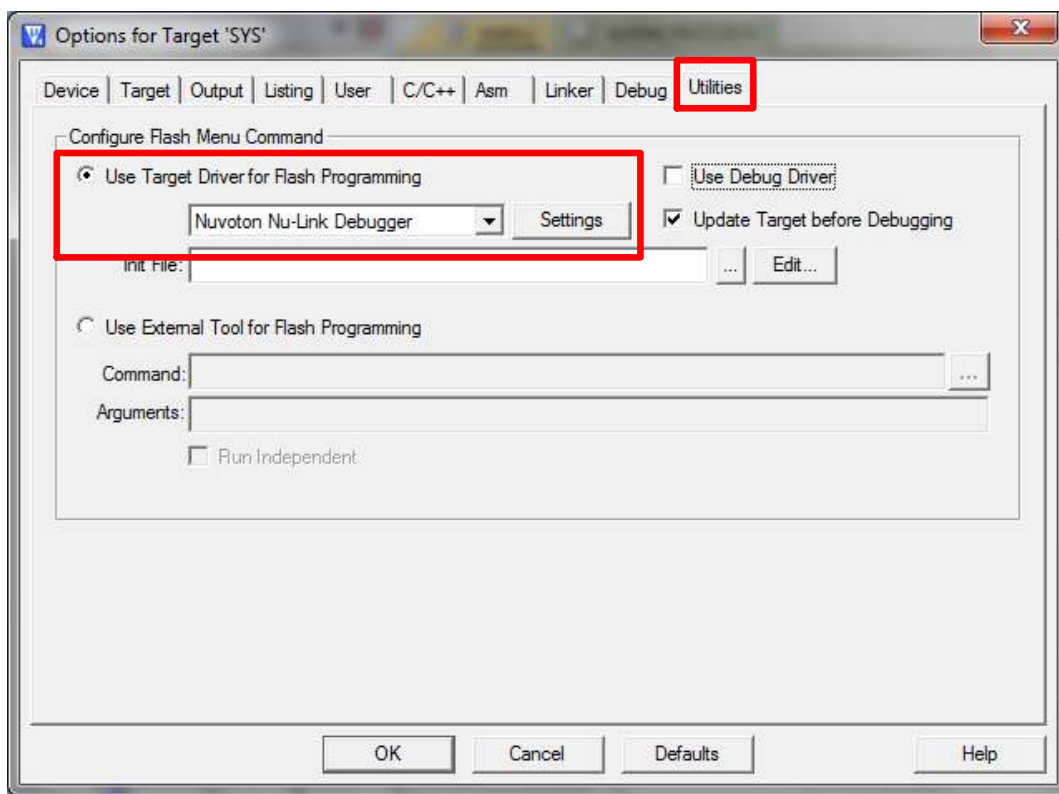

5.3.3 Build and Download Code to NuTiny-SDK-NUC123

Please build the project and download code to NuTiny-SDK-NUC123.

5.3.4 Open the Serial Port Terminal

User can use serial port terminal, PuTTY for example, to print out debug message.

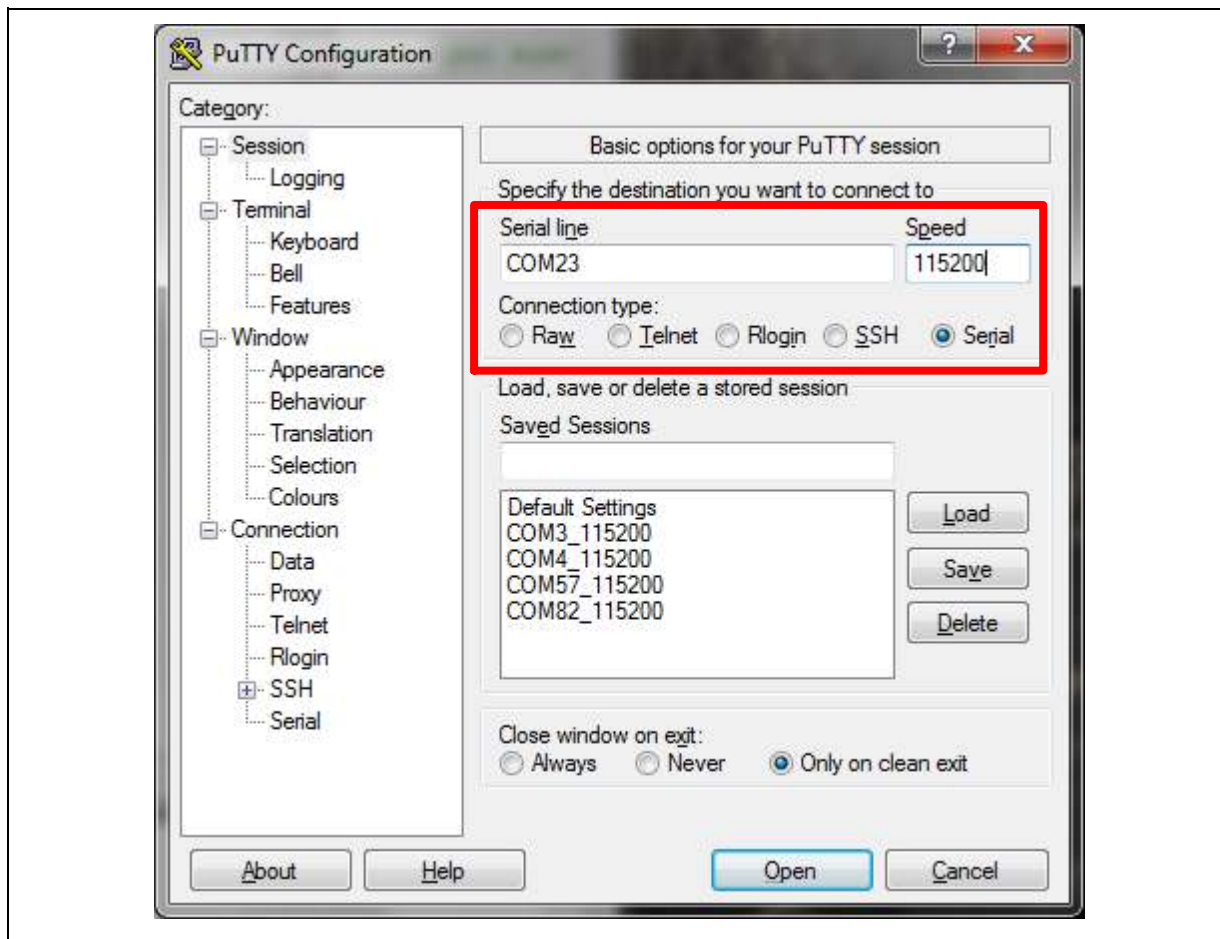

Figure 5-6 Set Baud Rate

5.3.5 Reset Chip

After pushing the reset button, the chip will reprogram application and print out debug message.

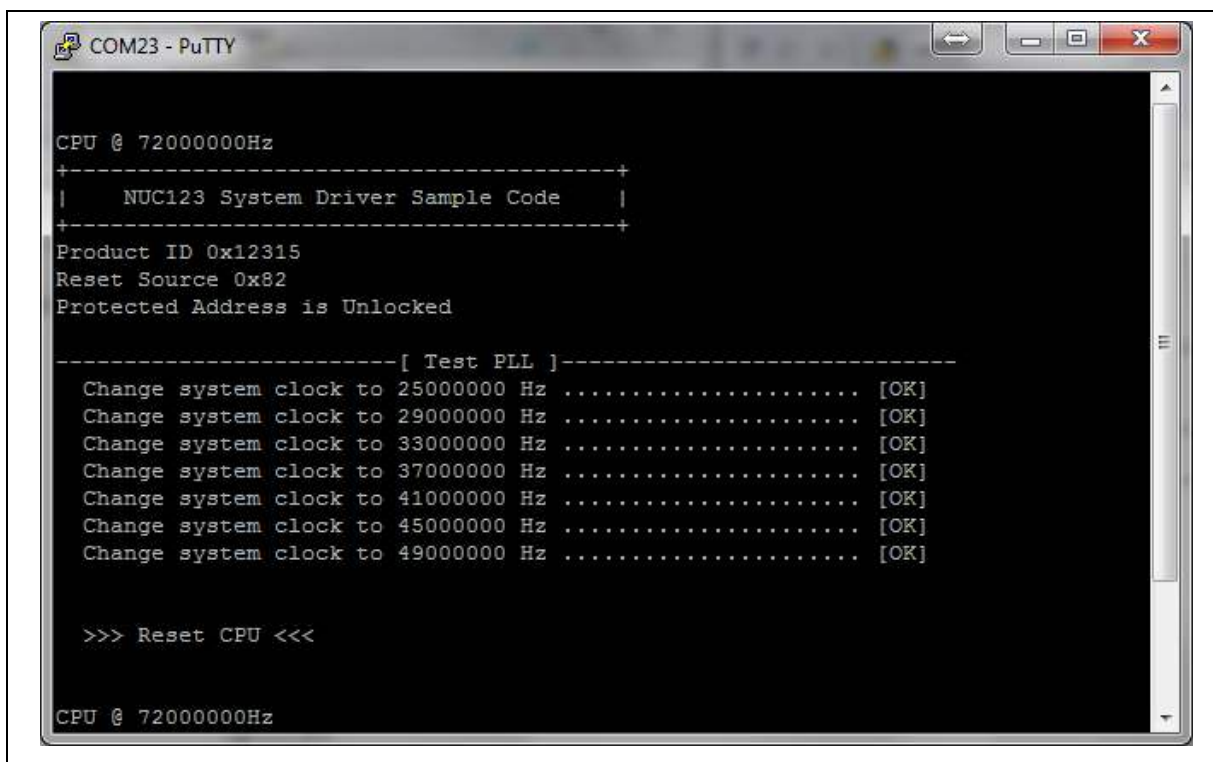
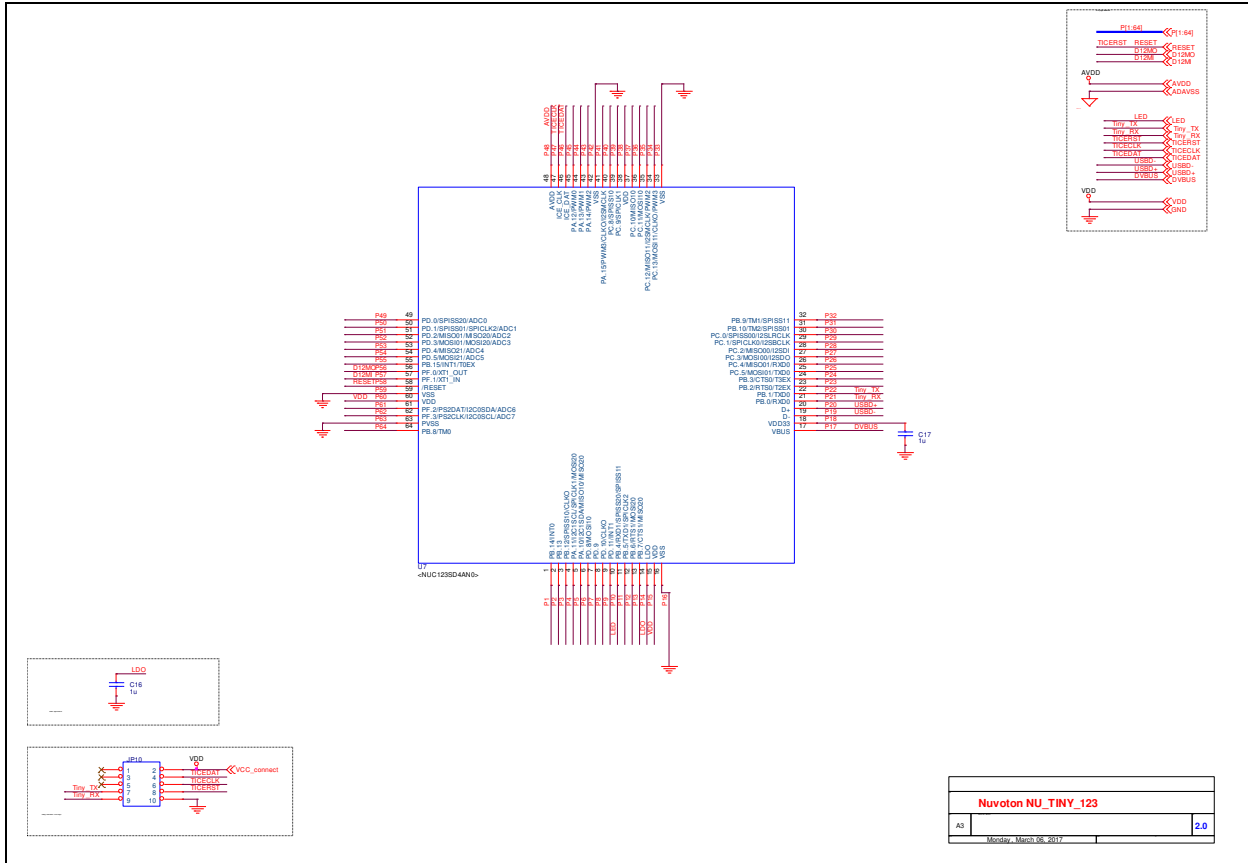

Figure 5-7 Serial Port Terminal Windows

Notice: Please switch SW2 on before the NuTiny-SDK-NUC123 connects to the PC. When the NuTiny-SDK-NUC123 connects to the PC with SW2 switch on, PC will detect VCOM as a USB device and the detection will only be processed once. VCOM will not function if switch on SW2 after the connection.

6 NUTINY-SDK-NUC123 SCHEMATIC

6.1 NuTiny-EVB-NUC123 Schematic



6.2 GPIO for 100 pin Schematic

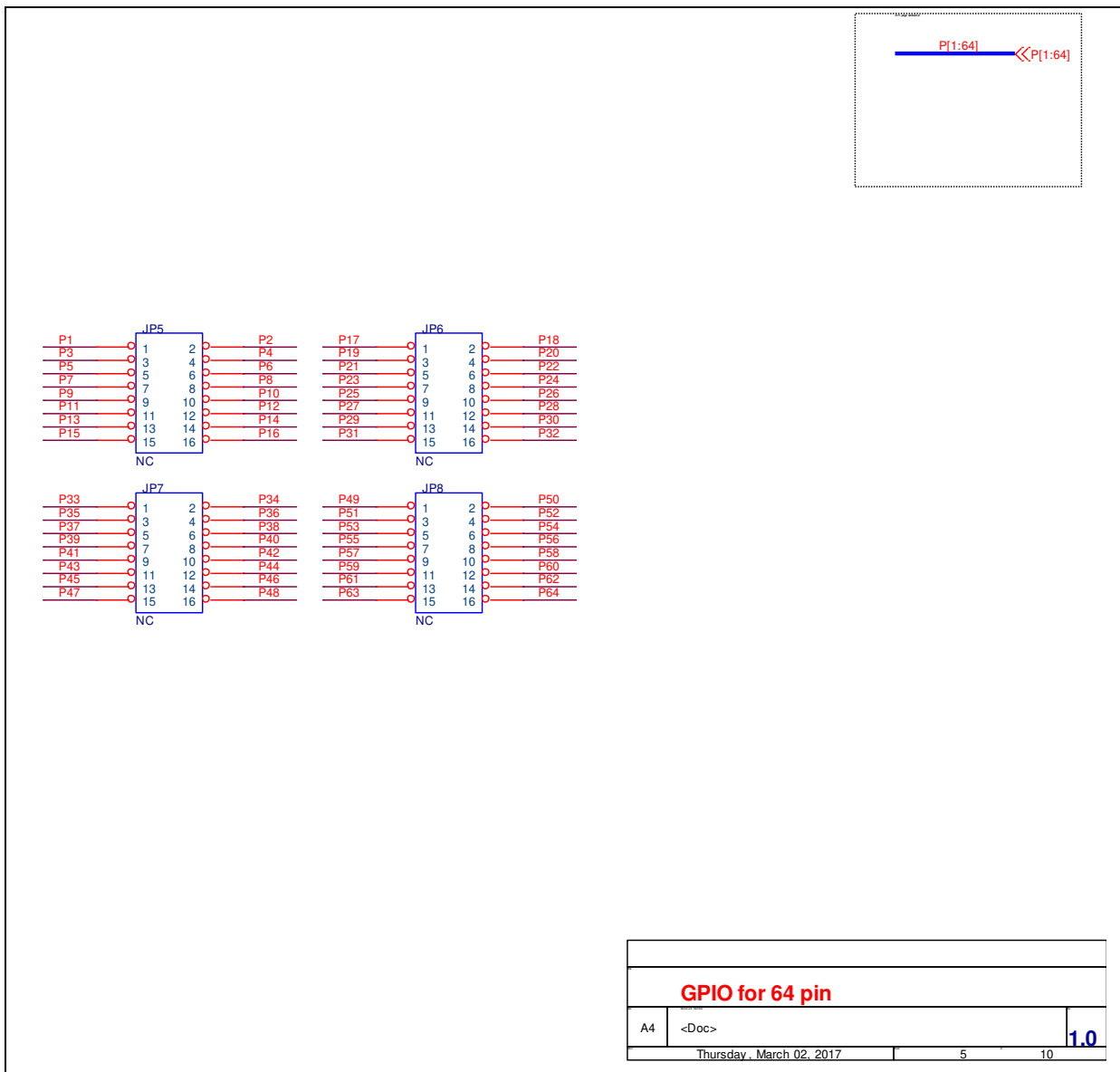

GPIO for 64 pin	
A4	<Doc> 1.0
Thursday, March 02, 2017	
5	10

6.3 SDK Circuit Schematic

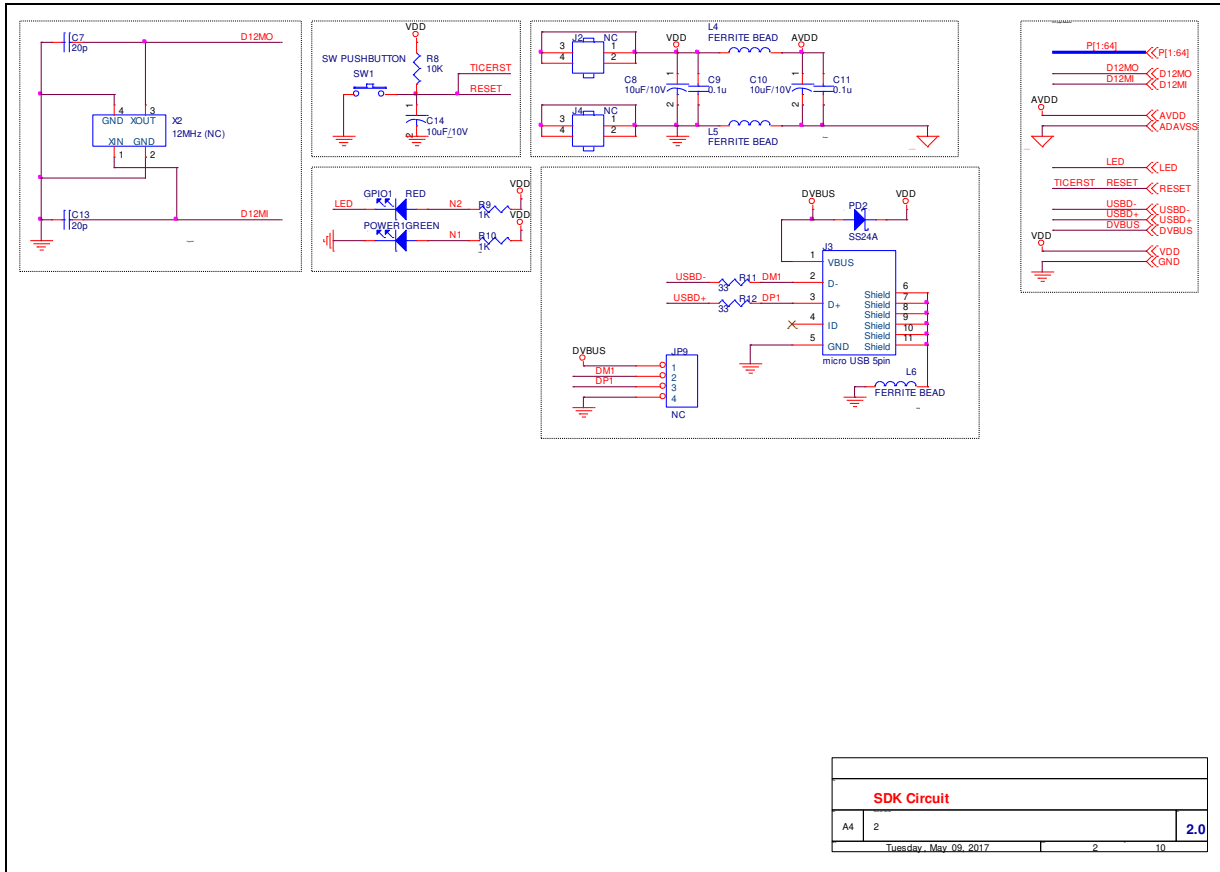

6.4 Nu-Link-Me V3.0 Schematic

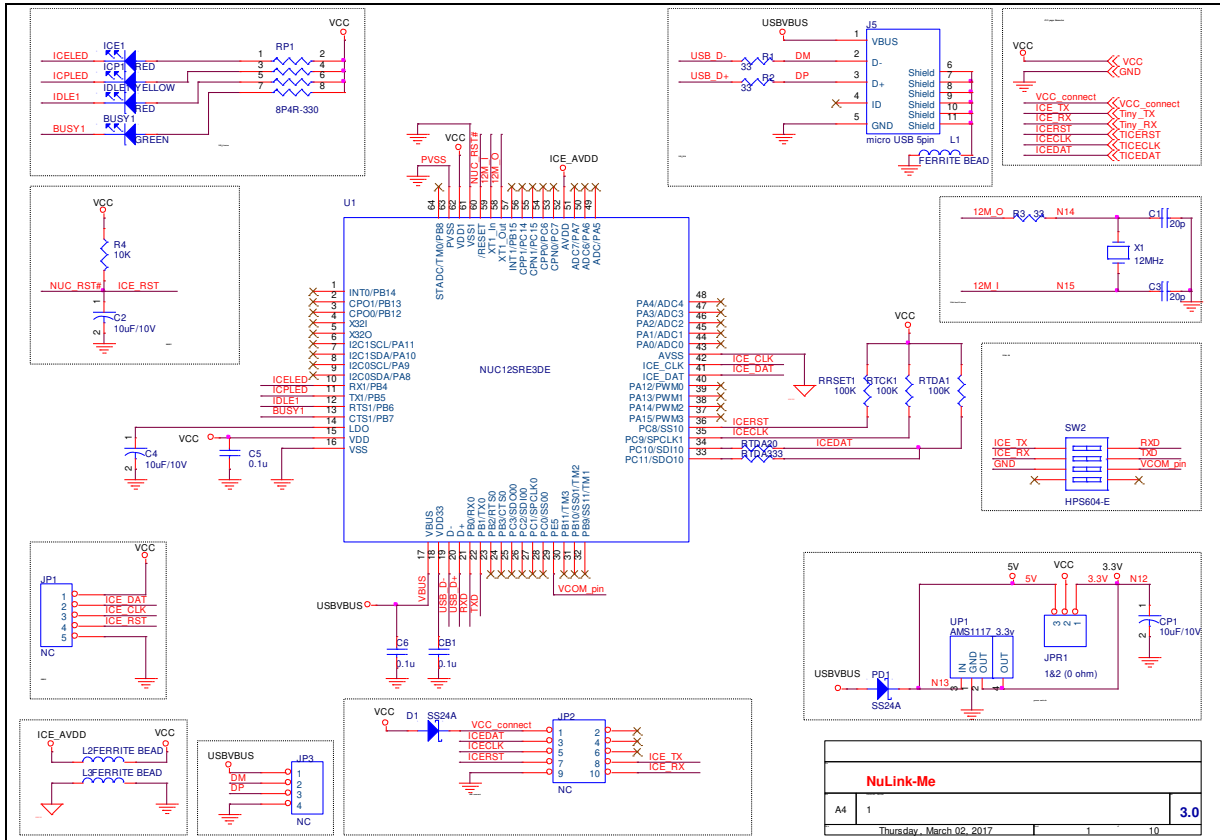

7 REVISION HISTORY

Date	Revision	Description
2012.08.16	1.00	1. Initially issued.
2017.05.09	1.01	<ol style="list-style-type: none"> 1. Updated the figure of NuTiny-SDK-NUC123 PCB Board in section 2. 2. Updated the Jumper descriptions of NuTiny-SDK-NUC123 in section 2.1. 3. Updated the figure of NuTiny-SDK-NUC123 PCB Placement in section 2.3. 4. Updated the descriptions of example program in section 3.4 and section 4.4. 5. Added the descriptions of Nu-Link Me V3.0 in section 2 and section 5. 6. Updated the schematics of NuTiny-SDK-NUC123 in section 6.

Important Notice

Nuvoton Products are neither intended nor warranted for usage in systems or equipment, any malfunction or failure of which may cause loss of human life, bodily injury or severe property damage. Such applications are deemed, "Insecure Usage".

Insecure usage includes, but is not limited to: equipment for surgical implementation, atomic energy control instruments, airplane or spaceship instruments, the control or operation of dynamic, brake or safety systems designed for vehicular use, traffic signal instruments, all types of safety devices, and other applications intended to support or sustain life.

All Insecure Usage shall be made at customer's risk, and in the event that third parties lay claims to Nuvoton as a result of customer's Insecure Usage, customer shall indemnify the damages and liabilities thus incurred by Nuvoton.

*Please note that all data and specifications are subject to change without notice.
All the trademarks of products and companies mentioned in this datasheet belong to their respective owners.*