

NOTES:

1. MATERIALS AND FINISHES:
  - BODY - ZINC DIE CAST, NICKEL PLATED [.000150 MIN THICK]
  - CONTACT - PHOSPHOR BRONZE, GOLD PLATED [.000003 MIN THICK], OVER TIN PLATING [.000100 MIN THICK], OVER NICKEL PLATING [.000050 MIN THICK] GOLD PLATING AT CONTACT AREA, AND TIN OVER NICKEL PLATING OVER ALL
  - INSULATOR - POLYPROPYLENE, UL94 HB FLAMMABILITY RATING
  - GROUND TER. - COPPER WIRE, TIN PLATED [.000100 MIN THICK]
  - LEGS - BRASS, TIN PLATED [.000100 MIN THICK]

2. ELECTRICAL:
  - A. IMPEDANCE: 75 OHM

4. PACKAGING:
  - A. QUANTITY: BULK PACK OF 50 PER TRAY
  - B. MARKING : TRAY TO BE MARKED "AMPHENOL, 31-71042, AND DATE CODE"

31-71042		REVISIONS			
DRAWING NO.	REV	DESCRIPTION	DATE	ECO	APPR
THIRD ANGLE PROJ.	A	RELEASE TO MFG.	21-Aug-95	40712	CPM
	B	REDRAWN IN PRO/E	8/6/04	45094	HP
	C	SEE SHEET I	3/7/05	45399	CPM
	D	SEE SHEET I	10/7/08	46939	MAH
	E	SEE SHEET I	9/4/09	47784	CPM

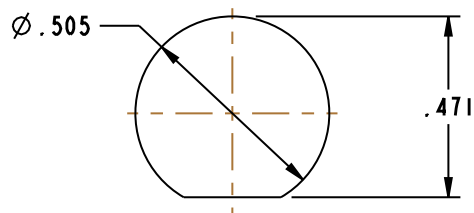

RECOMMENDED PANEL CUT-OUT

SCALE 2.000

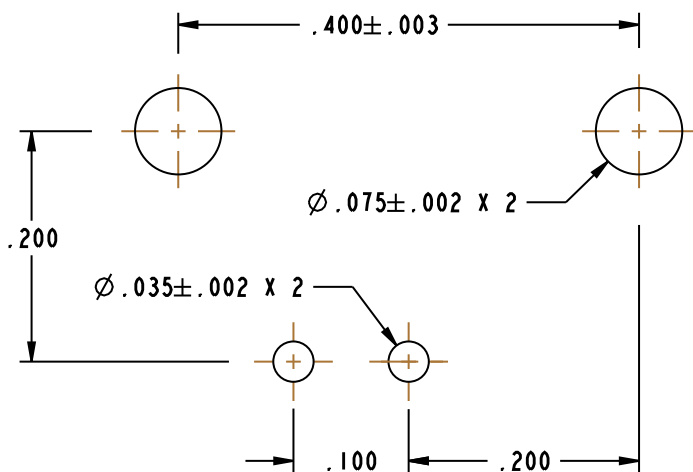

RECOMMENDED PCB CUT-OUT

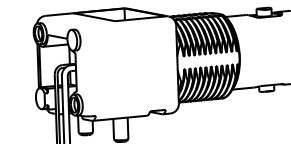
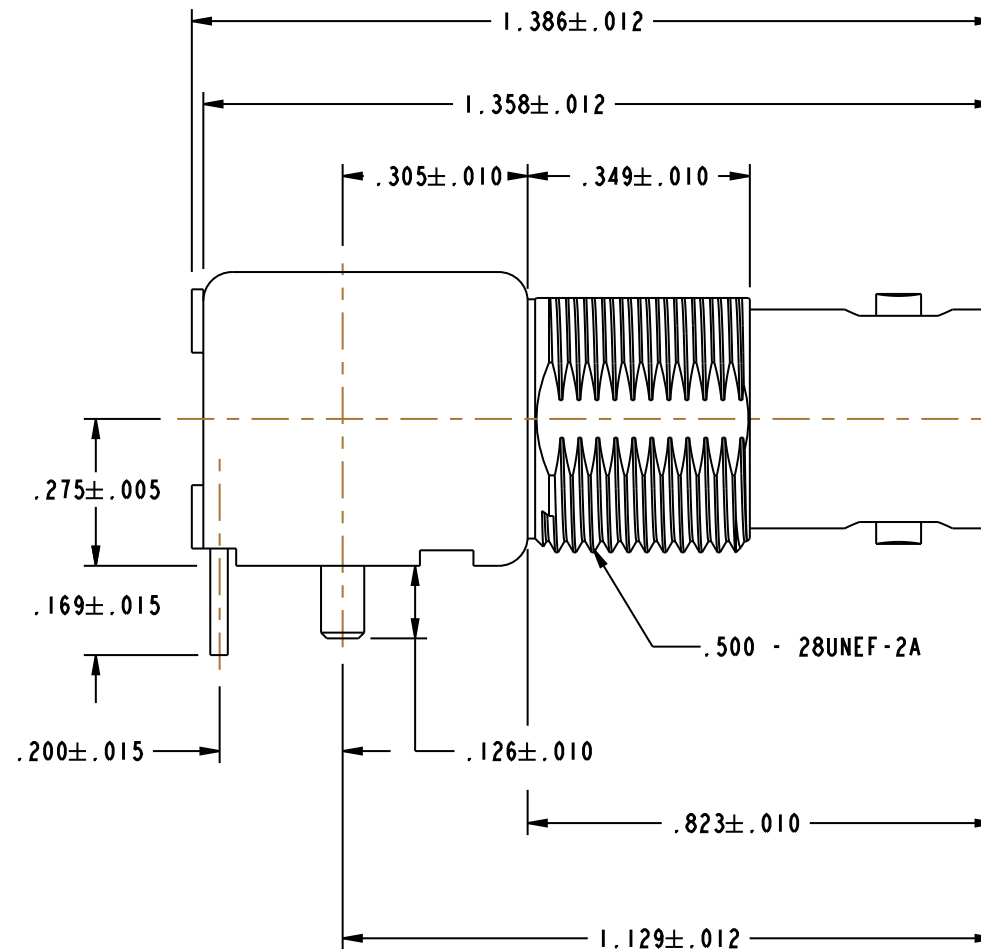
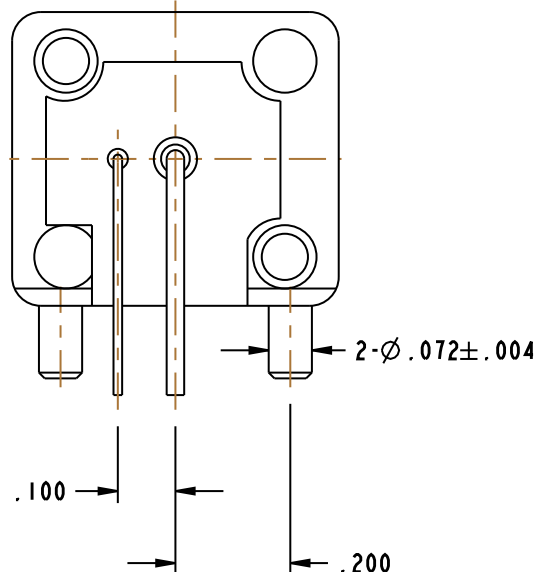

SCALE 1.000

**CUSTOMER OUTLINE DRAWING**  
ALL OTHER SHEETS ARE FOR INTERNAL USE ONLY

UNLESS OTHERWISE SPECIFIED, DIMENSIONS ARE IN INCHES AND TOLERANCES ARE:  
2 PLACE DECIMAL ±.015 (0,381 mm) 3 PLACE DECIMAL ±.005 (0,127 mm) ANGLES ± 1°

NOTICE - These drawings, specifications, or other data (1) are, and remain the property of Amphenol Corp. (2) must be returned upon request; and (3) are confidential and not to be disclosed to any person other than those to whom they are given by Amphenol Corp. The furnishing of these drawings, specifications, or other data by Amphenol Corp., or to any other person to anyone for any purpose is not to be regarded by implication or otherwise in any manner licensing, granting rights or permitting such holder or any other person to manufacture, use or sell any product, process or design, patented or otherwise, that may in any way be related to or disclosed by said drawings, specifications, or other data.

MATERIAL  
  
REFERENCE  
EAR# 1452  
EAR# 2272

DRAWN  
H. PARIKH  
DATE  
28-Jul-04  
ENGINEER  
H. PARIKH  
DATE  
28-Jul-04  
APPROVED  
O. BARTHELMES  
DATE  
8/4/04  
CAD FILE  
I:\BNC\31-71042

TITLE  
75 OHMS BNC JACK  
R/A, PCB MT.,  
ZINC DIE CAST HOUSING

Amphenol RF  
Danbury, CT, USA  
Tainan, Taiwan  
Shenzhen, China  
www.amphenolrf.com

SCALE: 3.0:1 SHEET 2 OF 2

CODE ID 74868	DWG SIZE B	DRAWING NO. 31-71042	REV E
------------------	---------------	-------------------------	----------