

REVISIONS					
REV	ECO	DESCRIPTION	DATE	BY	APPR
B1	-	RELEASE NEW DWG FORMAT	06/16/14	TOD	TOMMY

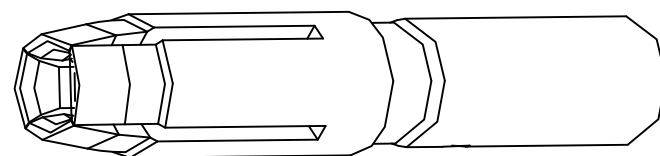
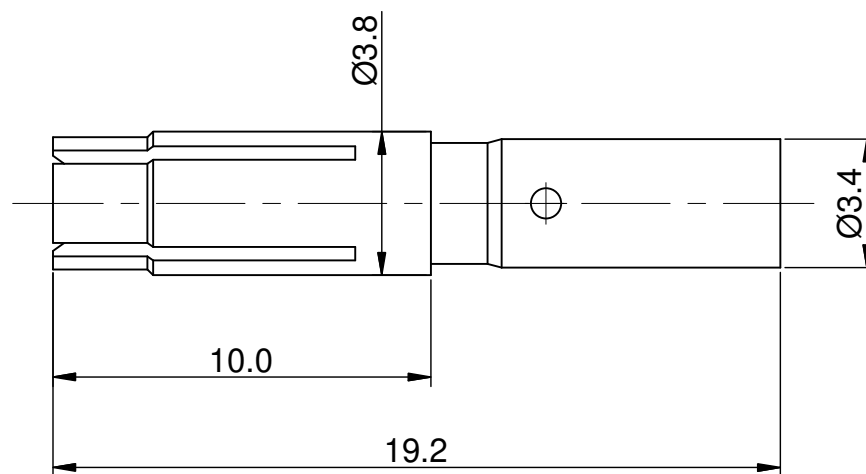
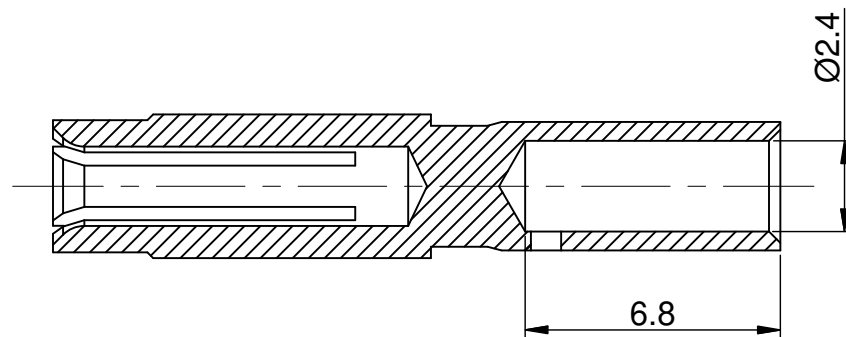
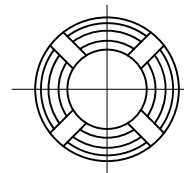

NOTES: UNLESS OTHERWISE SPECIFIED

1. MATERIAL: COPPER ALLOY, GOLD PLATED
2. SPECIFICATIONS:
 - 2.1 RATED CURRENT: 30 AMPS
 - 2.2 CONTACT RESISTANCE: <3 milliohm
 - 2.3 AVAILABLE WIRE RANGE: 18AWG~14AWG
 - 2.4 RoHS COMPLIANT
3. ALL DIMENSIONS ARE FOR REFERENCE USE ONLY.

TITLE: Socket,Machined,14#,Crimp 18-14AWG

DWG NO: SC000045

REV: B1

SH: 1

OF: 1

QUANTITY	SEE PART NUMBER CHART PART NUMBER	DESCRIPTION	ITEM
MATERIALS LIST			
UNLESS OTHERWISE SPECIFIED 1) All dimensions are in metric(mm). 2) Tolerances are as follows: 1 PL DEC ±0.30 2 PL DEC ±0.15 3 PL DEC ±0.08 Fractions ±1/64 Angles ±1° 3) Note reference =		SIGNATURES DRAWN: Tod CHECKED: ENGINEER: APPROVAL: DATE 06/16/14	<h1>Amphenol</h1> <p>Sine Systems - www.amphenol-sine.com 44724 Morley Drive Clinton Township, MI 48036</p>
MATERIAL SPECIFICATIONS:		CUSTOMER:	Socket,Machined,14#,Crimp 18~14AWG
PROCESS SPECIFICATIONS:		THIS DRAWING IS SUPPLIED FOR INFORMATION ONLY. DESIGN FEATURES, SPECIFICATIONS AND PERFORMANCE DATA SHOWN HEREON ARE THE PROPERTY OF THE AMPHENOL CORPORATION. NO RIGHTS OF REPRODUCTION ARE IMPLIED. ALL DIMENSIONS ARE SUBJECT TO NORMAL MANUFACTURING VARIATIONS.	
NEXT ASSY:		SIZE: B TYPE: C- SCALE: NONE	DWG NO: SC000045 REVISION: B1 SHEET 1 OF 1