

P.C.B. HOLE DRILLINGS
(P.C.B. TOP SIDE)

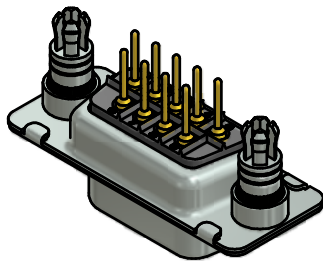
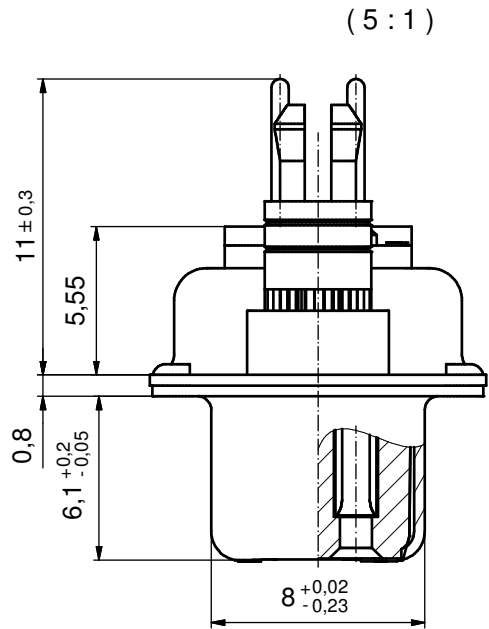
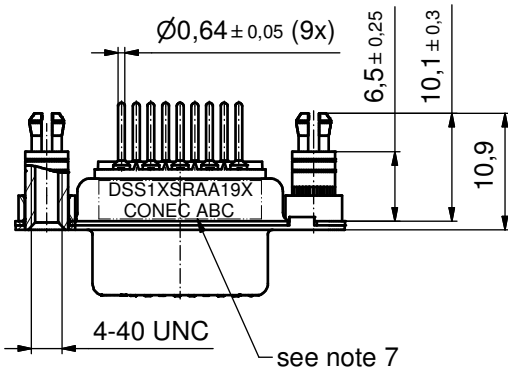
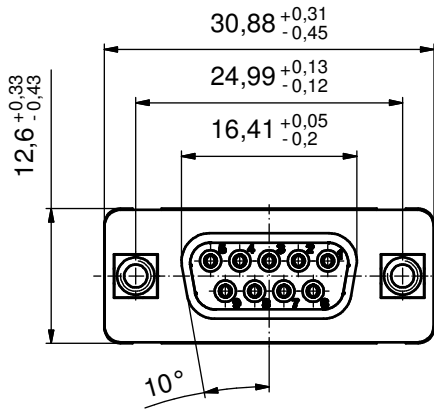

Directive 2002/95/EC
RoHS[®]
Compliant

NOTES:

- METALSHHELLS: STEEL; min. 315µin TIN over 40-80µin NICKEL
- INSULATORS: PBT GF UL 94 V-0, BLACK
- CONTACTS: COPPER ALLOY
PLATING: GOLD FLASH over NICKEL
- THREADED SPACER CLIPS:
COPPER ALLOY; min. 200µin TIN over 80µin NICKEL
PCB-HOLE: $\varnothing 3.1 \pm 0.1$; PCB THICKNESS 2,3mm
- COLLARS: COPPER ALLOY; min. 200µin TIN over 80µin NICKEL
- MAXIMUM TORQUE VALUE FOR THREAD: 6 in.LB
- CONNECTOR IS PART MARKED: **DSS1XSRAA19X CONEC ABC**

APPROVAL # FREIGABE # DEBLOCAGE # AUTORIZACION # APPROVAL	
CUSTOMER APPROVAL DATE:	
NAME:	TITLE:
COMPANY NAME:	
APPROVAL # FREIGABE # DEBLOCAGE # AUTORIZACION # APPROVAL	

THIS DRAWING MAY NOT BE COPIED OR REPRODUCED IN ANY WAY, AND MAY NOT BE PASSED ON TO A THIRD PARTY WITHOUT WRITTEN PERMISSION. OWNERSHIP AND COPYRIGHT OF CONEC GmbH			
DO NOT ALTER CAD DRAWING BY HAND			
rev.	description	date	name
a	Origin		

tolerance		scale:	2:1 (5:1)
	dim. in mm	material:	see notes
date	name	title:	
drawn 23.11.10	Henneboel	D-SUB FEMALE	
appd. 23.11.10	Koch	9pos. SOLDER PIN STRAIGHT	
norm		with threaded spacer clip	
d-old		dwg no:	Inventor 10
			DIN-A3
			sh: 1
		part no:	DSS1XSRAA19X

