



RFM Integrated Device, Inc.

PRODUCT SPECIFICATION

Part Number: XO6000

XO,156.25M +/-30 -40C
to +85C LVPECL

SMD, 5.0 X 3.2, 156.25 MHz, Crystal Oscillator



Features:

- Surface Mount Seam Weld Package
- Excellent Reliability Performance
- Good Frequency Perturbation and Stability over temperature
- Moisture Sensitivity Level (MSL) : Level-1

Application:

- 3.3 V Supply Voltage Operation / Complementary LVPECL Output
- Option-able stand-by function for output (Tri-state output)

Electrical Characteristics:

| XO6000 | Specifications |
|--|--|
| Nominal Frequency, Fo | 156.250000 MHz |
| Storage Temperature Range | -55°C to +150°C |
| Operating Temperature Range | -40°C to +85°C |
| Power Supply Voltage, Vcc | 3.3 V +/- 5% |
| Load | 50 ohm (LVPECL) |
| “0” Level “1” Level | 0.87 V max 1.47 V min |
| Output Voltage Swing | 595 mV min , 750 mV typ. , 930 mV max |
| Frequency Tolerance | +/-30 ppm max |
| Power Supply Current, Icc | 30 mA typ 50 mA max |
| Rise Time (20% -> 80% of final RF level in Vp-p) Fall Time (80% -> 20% of final RF level in Vp-p) | 0.3 nsec typ ; 0.5 nsec max. 0.3 nsec typ ; 0.5 nsec max. |
| Duty Cycle | 45% ~ 55% |
| Start - Up Time | 5.0 msec typ. , 10 msec max |
| RMS Phase Jitter (12K~20MHz) | 0.2 ps typ ; 0.5 ps max. |
| Aging | +/-3.0 ppm /1 st year |

| | |
|---|--|
| SSB Phase Noise (@10Hz Carrier Offset) | -50 dBc/Hz typ |
| SSB Phase Noise (@100Hz Carrier Offset) | -80 dBc/Hz typ |
| SSB Phase Noise (@1KHz Carrier Offset) | -115 dBc/Hz typ |
| SSB Phase Noise (@10KHz Carrier Offset) | -135 dBc/Hz typ |
| SSB Phase Noise (@1MHz Carrier Offset) | -142 dBc/Hz typ |
| SSB Phase Noise (@10MHz Carrier Offset) | -147 dBc/Hz typ |
| Enable/Disable Function | PIN 1: High or Open, PIN 3:Output Enable PIN 1: Low, PIN 3:Output Disable |

#Note 1: Frequency accuracy includes 25C tolerance, operating temperature range -40 to 85 deg C, aging and voltage or load change

Mechanical Dimensions: (Unit: mm)

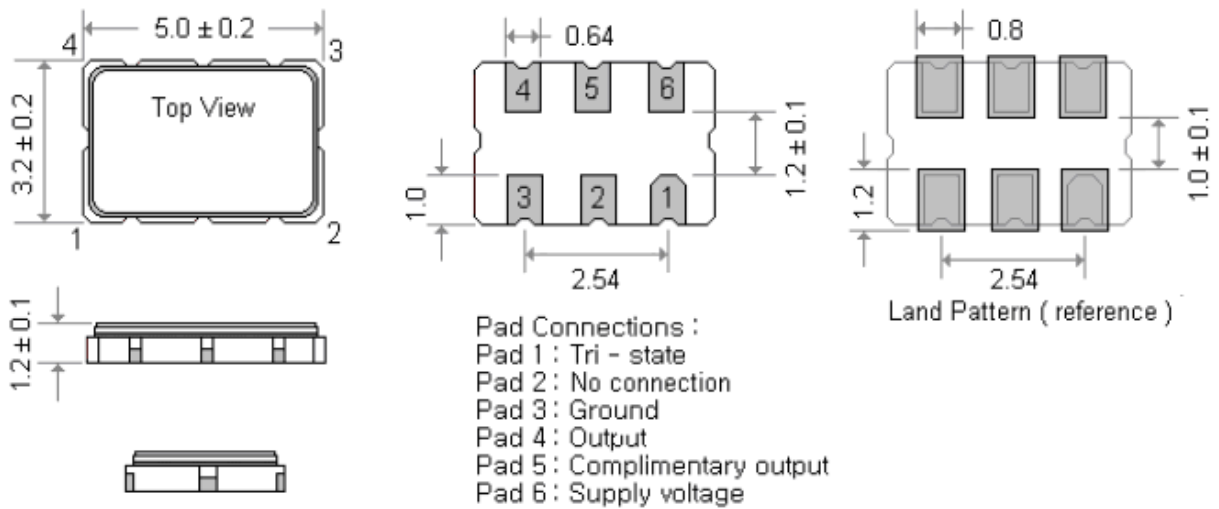

Test Circuit:

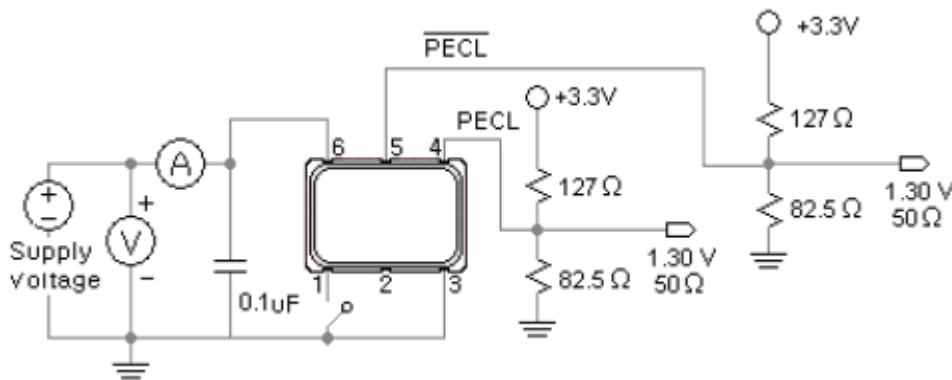

Output Waveform :

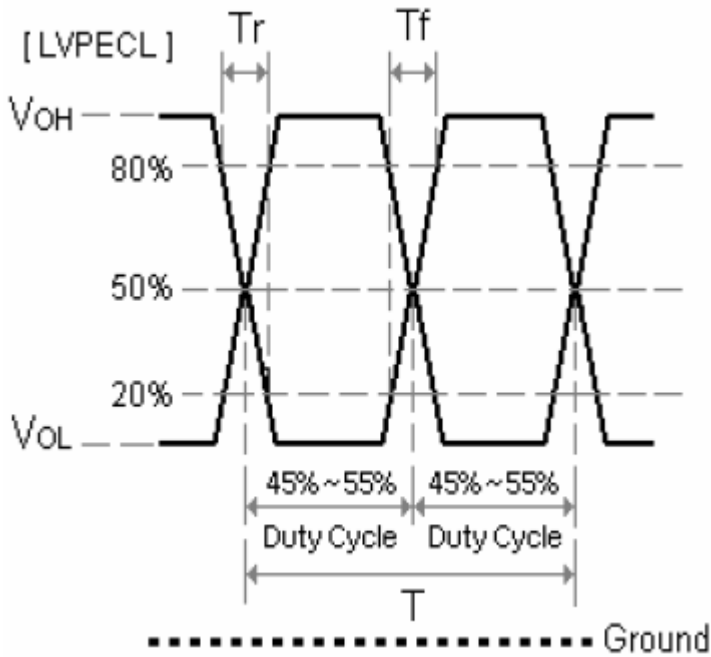

Marking:

Line 1 : Frequency (156.250)

Line 2 : $\text{\textcircled{T}}$ WDXX (Product Code + Data Code + internal Traceability Code, Can be 1 or 2 letters, example: XX)

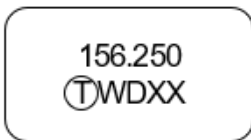

Product Code Table

| | | | | |
|--------------|------|------|----------|----------|
| Year | 2017 | 2018 | 2019 | 2020 |
| | 2021 | 2022 | 2023 | 2024 |
| | 2025 | 2026 | 2027 | 2028 |
| Product code | W | w | <u>W</u> | <u>w</u> |

Date Code Table

| Date Code Table | | | | | | | | | | | | |
|-----------------|------|------|------|------|------|------|------|------|------|------|------|------|
| WK01 | WK02 | WK03 | WK04 | WK05 | WK06 | WK07 | WK08 | WK09 | WK10 | WK11 | WK12 | WK13 |
| A | B | C | D | E | F | G | H | I | J | K | L | M |
| WK14 | WK15 | WK16 | WK17 | WK18 | WK19 | WK20 | WK21 | WK22 | WK23 | WK24 | WK25 | WK26 |
| N | O | P | Q | R | S | T | U | V | W | X | Y | Z |
| WK27 | WK28 | WK29 | WK30 | WK31 | WK32 | WK33 | WK34 | WK35 | WK36 | WK37 | WK38 | WK39 |
| a | b | c | d | e | f | g | h | i | j | k | l | m |
| WK40 | WK41 | WK42 | WK43 | WK44 | WK45 | WK46 | WK47 | WK48 | WK49 | WK50 | WK51 | WK52 |
| n | o | p | q | r | s | t | u | v | w | x | y | z |

Packing:

1. Reel Dimension (Unit: mm)

7" Reel = 1000

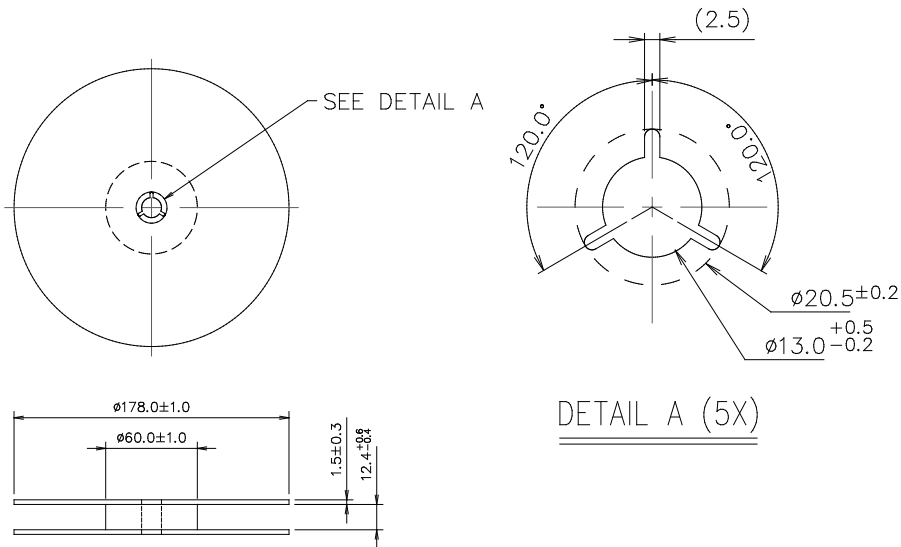

2. Tape Dimension (Unit: mm)

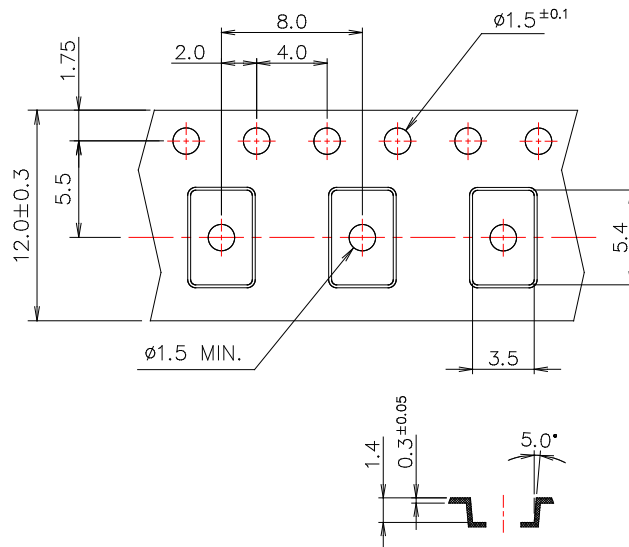

[NOTE]:

1. Unless otherwise specified tolerance on dimension +/-0.1 mm.
2. Material: conductive polystyrene with color black
3. 10 pitch cumulative tolerance +/-0.2 mm.
4. Packing Direction: dot or the logo of marking should be close to the hole of tape.

3. PACKING DIRECTION:

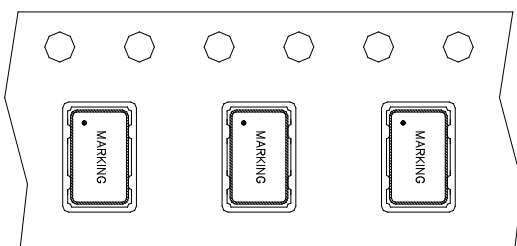

Packing Quantity/Packing: 1K pcs maximum per reel

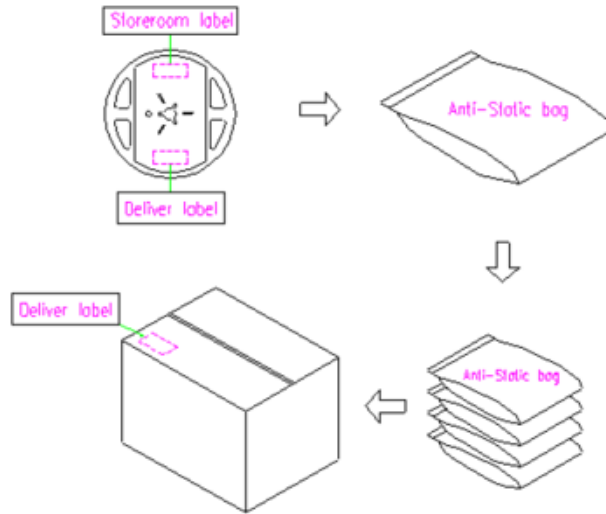

Reflow Profile:

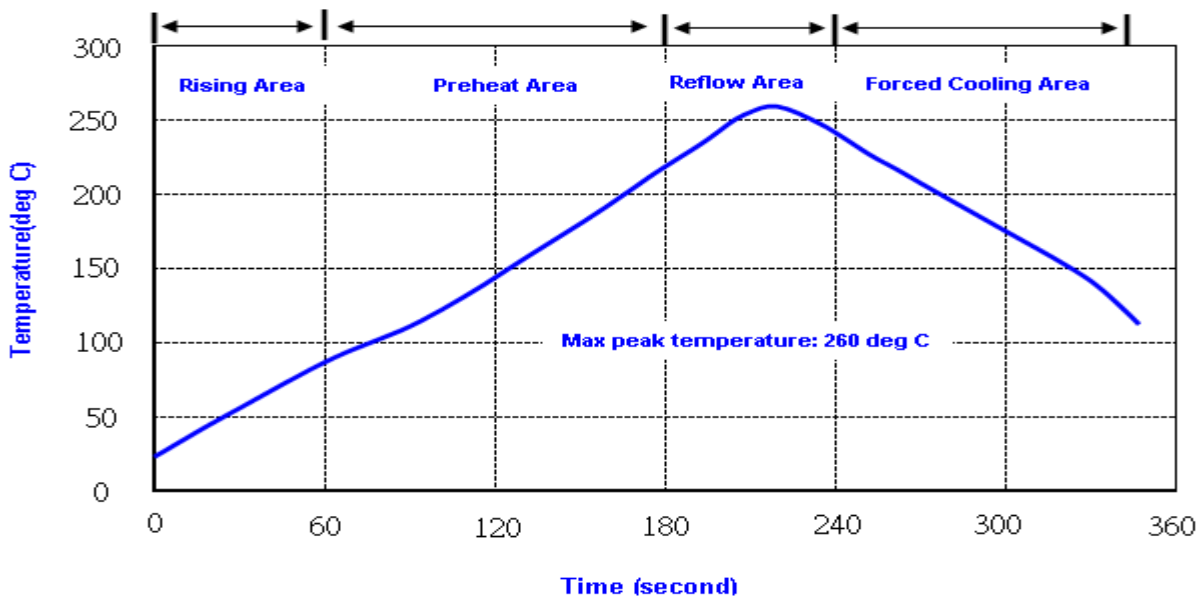

- Note:**
1. Max peak temperature: 260 \pm 5 deg C; Time: 10 \pm 2 sec
 2. Temperature: 217 \pm 5 deg C; Time: 90~100 sec

Reliability Specifications

| Test name | Test process / method | Reference standard |
|--|--|-------------------------------|
| Mechanical characteristics | | |
| resistance to Soldering heat (IR reflow) | Temp./ Duration : 265°C /10sec ×2 times Total time : 4min.(IR-reflow) | EIAJED-4701 -300(301)M(II) |
| Vibration | Total peak amplitude : 1.5mm Vibration frequency : 10 to 2000 Hz Sweep period : 20 minute Vibration directions : 3 mutually perpendicular Duration : 2 hr / direc. | MIL-STD 202G method 204 |
| Mechanical Shock | directions : 3 impacts per axis Acceleration : 3000g's, +20/-0 % Duration : 0.3 ms (total 18 shocks) Waveform : Half-sine | MIL-STD 202G method 213 |
| Solderability | Solder Temperature:265±5°C Duration time: 5±0.5 seconds. | J-STD-002 |
| Environmental characteristics | | |
| Thermal Shock | Heat cycle conditions -40 °C (30min) ←→ 85 °C (30min) * cycle time : 10 times | MIL-STD 883G method 1010.8 |
| Humidity test | Temperature : 85 ± 2 °C Relative humidity : 85% Duration : 96 hours | MIL-STD 202G method 103 |
| Dry heat (Aging test) | Temperature : 125 ± 2 °C Duration : 168 hours | MIL-STD 202G method 108A |
| Cold resistance (Low Temp Storage) | Temperature : -40 ± 2 °C Duration : 96 hours | IEC 60068-2-1 |