

© 1963 BY AMP INCORPORATED. ALL RIGHTS RESERVED. AMP PRODUCTS COVERED BY PATENTS AND/OR PATENTS PENDING.

330600

REVISIONS			
SYM	DESCRIPTION	DATE	APPO
A	TAN. RAD. ON TONGUE	10-2-63	JH
B	PER P-8292	1-30-79	JH
C	REV. PER P-8347	REB. 4/9/79	JH
D	REV G-4680	TMS 5-9-82 E-003	JT

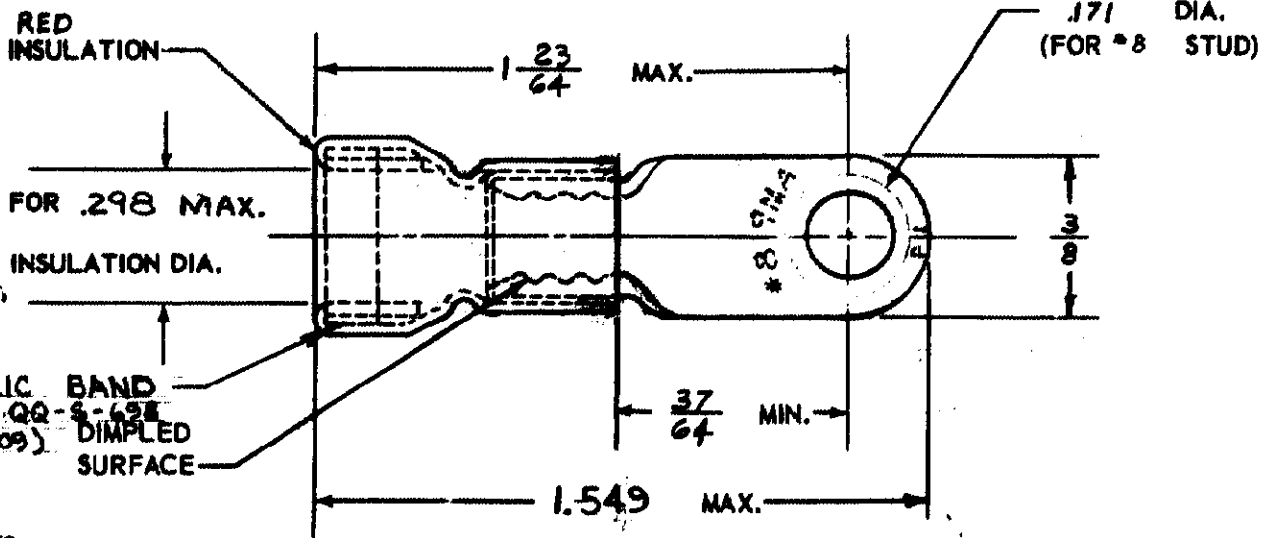

TONGUE MATERIAL THICKNESS .040

AMP INFO

LOC	PRINT	DATE
G	14	10

UNLESS OTHERWISE SPECIFIED DIMENSIONS ARE IN INCHES		
TOLERANCES ON		
FRACTIONS ± 1/64	DECIMALS ± .015	ANGLES ± 5°
MATERIAL TERMINAL COPPER (MIL-Q-Q-C-576)	SLEEVE P.V.C. INSULATION	
HEAT TREAT ANNEALED		
FINISH TIN PLATED (MIL-T-10727)		

SIGNATURE	DATE
DR <i>T. Lanthier</i>	8-15-63
CHK <i>J.W. Haines</i>	8/19/63
DESIGNOR	
APPRO <i>J.W. Haines</i>	8/19/63

AMP AMP INCORPORATED
HARRISBURG, PENNSYLVANIA

NAME

WIRE TERMINAL

AMPLI-BOND*
RING TONGUE
WIRE SIZE 8

DSGN APPO	CODE IDENT NO 00779	SIZE A	NUMBER 330600
OTHER APPO	SCALE 2:1	WT	CALC ACTUAL SHEET 1 OF 1