

# HC-STA-B16/B10-CESFD-PL-BK - Housing



1252470

<https://www.phoenixcontact.com/us/products/1252470>

Please be informed that the data shown in this PDF document is generated from our online catalog. Please find the complete data in the user documentation. Our general terms of use for downloads are valid.



Sleeve housing B16, for double locking latch, material: PA, straight, height: 99.5 mm, cable gland: none, Adapter sleeve for the CES cable entry system, Can be optimally combined with modular contact inserts

## Product description

Adapter sleeve for combining the CES cable entry system with the pluggability of a HEAVYCON housing. By combining the CES cable entry system and the adapter sleeve, several conductors can be conveniently inserted into a connector.

## Your advantages

- Labeling option using 9 x 20 mm marking label
- Simple assembly of multiple cables in a HEAVYCON housing
- Halogen-free plastic
- Marking label can be attached

## Commercial data

Item number	1252470
Packing unit	1 pc
Minimum order quantity	1 pc
Sales key	BF67
Product key	BF7CZX
GTIN	4063151360177
Weight per piece (including packing)	200.7 g
Weight per piece (excluding packing)	190.5 g
Customs tariff number	85389099
Country of origin	CN

# HC-STA-B16/B10-CESFD-PL-BK - Housing



1252470

<https://www.phoenixcontact.com/us/products/1252470>

## Technical data

### Notes

General	For module carrier frame B16
---------	------------------------------

### Product properties

Type	B16
Product type	Housing with locking latch
Housing type	Sleeve housing
Cable outlet	straight
Pg screw connection	none

### Dimensions

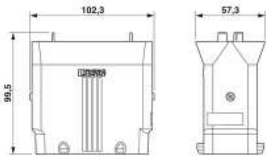
Dimensional drawing	
Width	57.3 mm
Height	99.5 mm
Length	102.3 mm

### Material specifications

Housing material	PA
------------------	----

### Mechanical properties

#### Mechanical data

Locking type	Pin
--------------	-----

### Mounting

Assembly instructions	The housing has to be extended by the B10 sealing frame with screw locking mechanism (Order No. 0801660). When combined with the sealing frame with screw locking mechanism, a simple assembly of multiple cables in a single HC housing is possible.
-----------------------	---

### Environmental and real-life conditions

#### Ambient conditions

Degree of protection	IP54
Ambient temperature (operation)	-40 °C ... 125 °C

# HC-STA-B16/B10-CESFD-PL-BK - Housing

1252470

<https://www.phoenixcontact.com/us/products/1252470>



## Drawings

Dimensional drawing

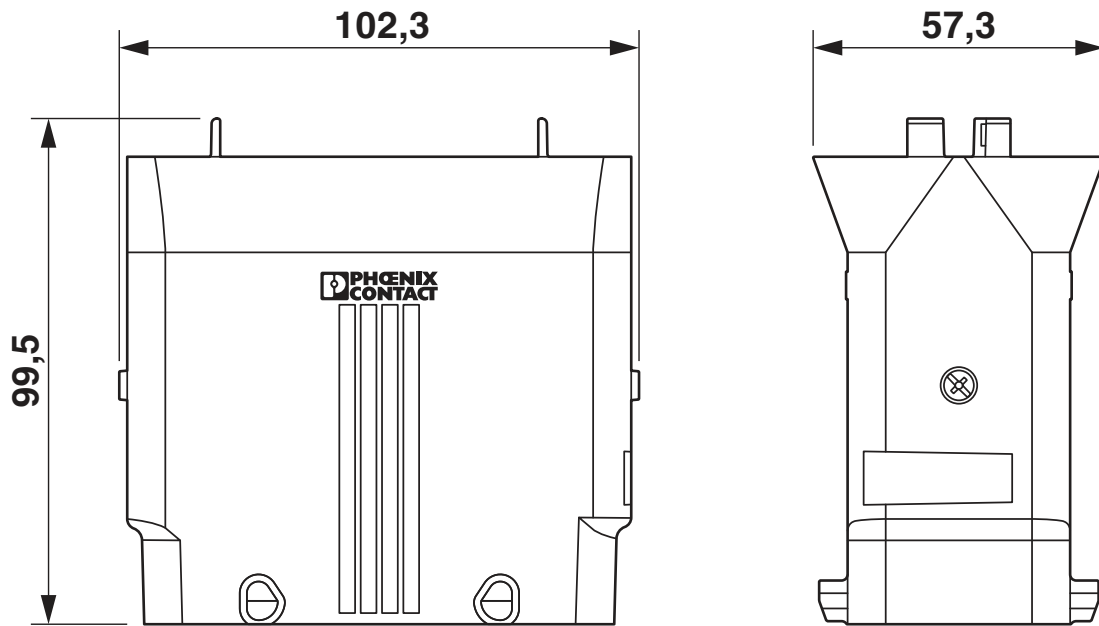

Dimensional drawing

# HC-STA-B16/B10-CESFD-PL-BK - Housing



1252470

<https://www.phoenixcontact.com/us/products/1252470>

## Classifications

### ECLASS

ECLASS-11.0	27440202
ECLASS-12.0	27440202
ECLASS-13.0	27440202

### ETIM

ETIM 8.0	EC000437
----------	----------

### UNSPSC

UNSPSC 21.0	31261500
-------------	----------

# HC-STA-B16/B10-CESFD-PL-BK - Housing



1252470

<https://www.phoenixcontact.com/us/products/1252470>

## Environmental product compliance

China RoHS	Environmentally friendly use period: unlimited = EFUP-e
	No hazardous substances above threshold values

# HC-STA-B16/B10-CESFD-PL-BK - Housing



1252470

<https://www.phoenixcontact.com/us/products/1252470>

## Accessories

### CES-B10-SFFS-PLBK - Sealing frame

0801660

<https://www.phoenixcontact.com/us/products/0801660>



Sealing frame, with screw locking, design: B10, Number of cable seals (small): 6, material: PA (halogen-free), color: black, length: 99.2 mm, width: 58 mm, height: 20 mm

### HC-M-B16-MFH-H - Module carrier frame

1182093

<https://www.phoenixcontact.com/us/products/1182093>



Module carrier frame, size: B16, type : for the sleeve side (A, B, C, ...), 4 mm<sup>2</sup> ... 6 mm<sup>2</sup>, application: Module carrier frame

Phoenix Contact 2023 © - all rights reserved

<https://www.phoenixcontact.com>

Phoenix Contact USA  
586 Fulling Mill Road  
Middletown, PA 17057, United States  
(+717) 944-1300  
[info@phoenixcon.com](mailto:info@phoenixcon.com)