

DATE	REV	ECN	APP'D. BY
3-8-16	A4	10595	TRM
8-29-17	A5	11079	TRM

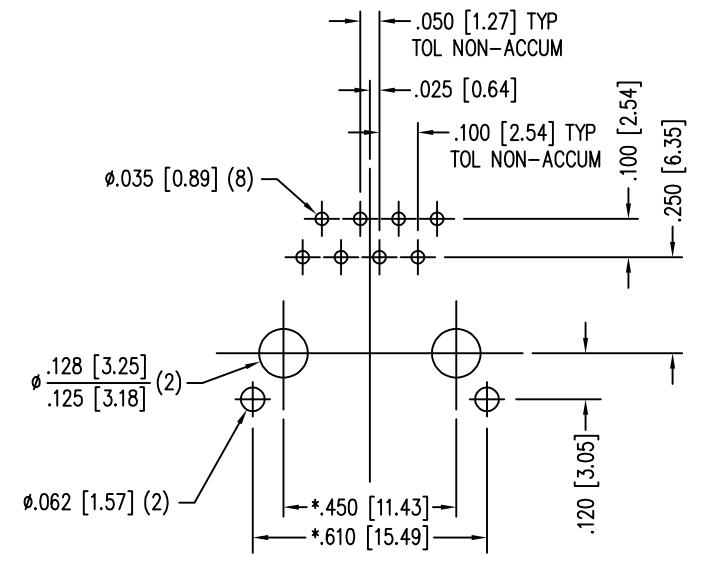
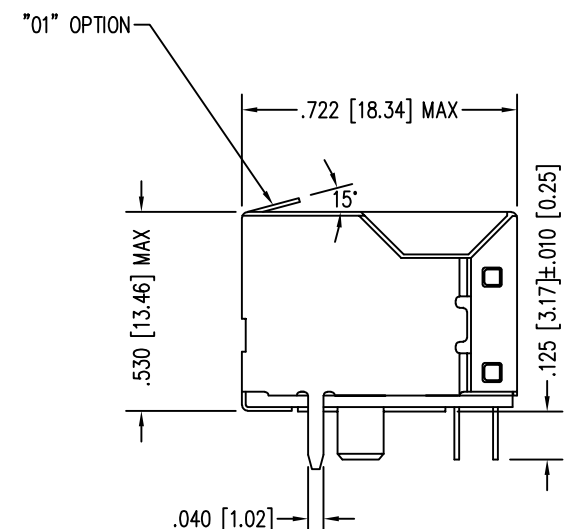
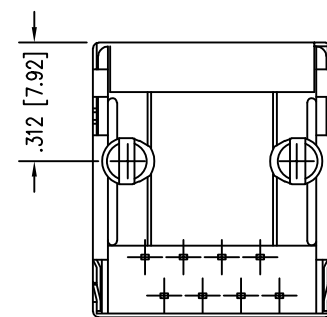
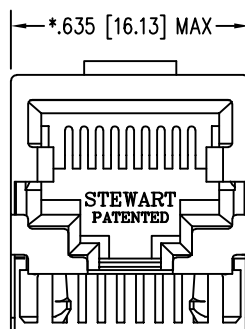
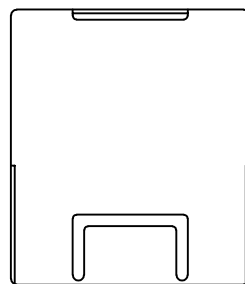

P.C.B. RECOMMENDED HOLE LAYOUT
 SEEN FROM COMPONENT SIDE
 TOLERANCE ±.003 [0.08] UNLESS OTHERWISE SPECIFIED

NOTES:

- CONNECTOR MATERIALS:
 HOUSING: THERMOPLASTIC UL94 V-0
 CONTACTS/SHIELD: COPPER ALLOY
 SHIELD PLATING: NICKEL OR TIN
 CONTACT PLATING: SELECTIVE GOLD IN CONTACT AREA
 SEE CHART FOR PART NUMBER
- FOR PRODUCT SPECIFICATIONS SEE PR022-01.
- DIMENSIONS AND TOLERANCES COMPLY WITH TIA-1096 STANDARD.

30 MICRO-INCHES [0.76um]	SS-640810S-A-NF-1-01-A111
CONTACT PLATING IN MATING AREA	PART NUMBER

THIRD ANGLE PROJECTION 	 a bel group	1118 Susquehanna Trail South Glen Rock, PA 17327-9199 (717) 235-7512 http://www.stewartconnector.com
DO NOT SCALE DRAWING DRAWING IS SUBJECT TO CHANGE WITHOUT NOTICE	TITLE: EIGHT POSITION, EIGHT CONTACT, SHIELDED SHORT VERSION JACK NON-FLANGED, ALT. SOLDER TAIL LOC., TOP PANEL GROUND AT 15°	
DIMENSIONS: INCHES [METRIC] UNLESS OTHERWISE SPECIFIED TOLERANCES ARE ±.005 [0.13] ANGLES ARE ± 1°	DRN BY: KRL DATE: 1/24/06	APPD BY: JM DATE: 1-26-06
SHEET NO. 1 OF 1	DWG NO. CT640135	REV. A5

