

SN75176B/SN65176B Multipoint RS-485/RS-422 Transceivers

FEATURES

- Meets EIA Standard RS485 for Multipoint Bus Transmission and is Compatible with RS-422.
- Small Outline (SOIC) Package Option Available for Minimum Board Space.
- 22 ns Driver Propagation Delays.
- Single +5V Supply.
- -7V to +12V Bus Common Mode Range Permits ±7V Ground Difference Between Devices on the Bus.
- Thermal Shutdown Protection.
- High Impedance to Bus with Driver in TRI-STATE or with Power Off, Over the Entire Common Mode Range Allows the Unused Devices on the Bus to be Powered Down.
- Combined Impedance of a Driver Output and Receiver Input is Less Than One RS485 Unit Load, Allowing up to 32 Transceivers on the Bus.
- 70 mV Typical Receiver Hysteresis.

DESCRIPTION

The SN75176B / SN65176B is a high speed differential TRI-STATE[®] bus/line transceiver designed to meet the requirements of EIA standard RS485 with extended common mode range (+12V to -7V), for multipoint data transmission. In addition, it is compatible with RS-422.

The driver and receiver outputs feature TRI-STATE capability, for the driver outputs over the entire common mode range of +12V to -7V. Bus contention or fault situations that cause excessive power dissipation within the device are handled by a thermal shutdown circuit, which forces the driver outputs into the high impedance state.

DC specifications are guaranteed over the 0 to 70°C temperature and 4.75V to 5.25V supply voltage range.

Connection and Logic Diagram

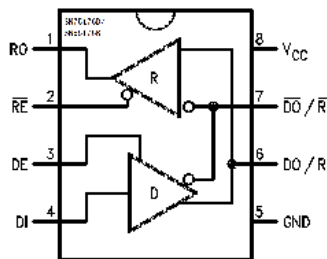

Figure 1. Top View



These devices have limited built-in ESD protection. The leads should be shorted together or the device placed in conductive foam during storage or handling to prevent electrostatic damage to the MOS gates.

Absolute Maximum Ratings ⁽¹⁾⁽²⁾

Supply Voltage, V_{CC}		7V
Control Input Voltages		7V
Driver Input Voltage		7V
Driver Output Voltages		+15V/ -10V
Receiver Input Voltages		+15V/ -10V
Receiver Output Voltage		5.5V
Continuous Power Dissipation @ 25°C	for SOIC Package	675 mW ⁽³⁾
	for PDIP Package	900 mW ⁽⁴⁾
Storage Temperature Range		-65°C to +150°C
Lead Temperature (Soldering, 4 seconds)		260°C
ESD Rating (HBM)		500V

- (1) "Absolute Maximum Ratings" are those beyond which the safety of the device cannot be verified. They are not meant to imply that the device should be operated at these limits. The tables of "Electrical Characteristics" provide conditions for actual device operation.
- (2) If Military/Aerospace specified devices are required, please contact the HG Sales Office/Distributors for availability and specifications.
- (3) Derate linearly @ 6.11 mW/°C to 400 mW at 70°C.
- (4) Derate linearly at 5.56 mW/°C to 650 mW at 70°C.

Recommended Operating Conditions

	Min	Max	Units
Supply Voltage, V_{CC}	4.75	5.25	V
Voltage at Any Bus Terminal (Separate or Common Mode)	-7	+12	V
Operating Free Air Temperature T_A			
SN75176B	0	+70	°C
SN65176B	-40	+105	°C
Differential Input Voltage, VID ⁽¹⁾	-12	+12	V

- (1) Differential - Input/Output bus voltage is measured at the noninverting terminal A with respect to the inverting terminal B.

Electrical Characteristics ^{(1) (2)}

0°C ≤ T_A ≤ 70°C, 4.75V < V_{CC} < 5.25V unless otherwise specified

Symbol	Parameter	Conditions	Min	Typ	Max	Units	
V_{OD1}	Differential Driver Output Voltage (Unloaded)	$I_O = 0$			5	V	
V_{OD2}	Differential Driver Output Voltage (with Load)	See (Figure 2)					
		R = 50Ω; (RS-422) ⁽³⁾	2			V	
			1.5			V	
ΔV_{OD}	Change in Magnitude of Driver Differential Output Voltage For Complementary Output States	See (Figure 2)			0.2	V	
V_{OC}	Driver Common Mode Output Voltage		R = 27Ω			3.0	V
$\Delta V_{OC} $	Change in Magnitude of Driver Common Mode Output Voltage For Complementary Output States					0.2	V

- (1) All currents into device pins are positive; all currents out of device pins are negative. All voltages are referenced to device ground unless otherwise specified.
- (2) All typicals are given for $V_{CC} = 5V$ and $T_A = 25°C$.
- (3) All worst case parameters for which this note is applied, must be increased by 10% for SN75176BT. The other parameters remain valid for -40°C < T_A < +85°C.

Electrical Characteristics ^{(1) (2)} (continued)
 $0^{\circ}\text{C} \leq T_A \leq 70^{\circ}\text{C}$, $4.75\text{V} < V_{CC} < 5.25\text{V}$ unless otherwise specified

Symbol	Parameter	Conditions	Min	Typ	Max	Units	
V_{IH}	Input High Voltage	DI, DE, RE, E	2			V	
V_{IL}	Input Low Voltage				0.8		
V_{CL}	Input Clamp Voltage		$I_{IN} = -18\text{ mA}$			-1.5	
I_{IL}	Input Low Current		$V_{IL} = 0.4\text{V}$			-200	μA
I_{IH}	Input High Current		$V_{IH} = 2.4\text{V}$			20	μA
I_{IN}	Input Current	DO/RI, $\overline{\text{DO}}/\overline{\text{RI}}$ $V_{CC} = 0\text{V}$ or 5.25V $\text{DE} = 0\text{V}$			+1.0	mA	
					-0.8	mA	
V_{TH}	Differential Input Threshold Voltage for Receiver	$-7\text{V} \leq V_{CM} \leq +12\text{V}$	-0.2		+0.2	V	
ΔV_{TH}	Receiver Input Hysteresis	$V_{CM} = 0\text{V}$		70		mV	
V_{OH}	Receiver Output High Voltage	$I_{OH} = -400\ \mu\text{A}$	2.7			V	
V_{OL}	Output Low Voltage	RO $I_{OL} = 16\text{ mA}^{(3)}$			0.5	V	
I_{OZR}	OFF-State (High Impedance) Output Current at Receiver	$V_{CC} = \text{Max}$ $0.4\text{V} \leq V_O \leq 2.4\text{V}$			± 20	μA	
R_{IN}	Receiver Input Resistance	$-7\text{V} \leq V_{CM} \leq +12\text{V}$	12			k Ω	
I_{CC}	Supply Current	No Load ⁽³⁾			55	mA	
		Driver Outputs Enabled			35	mA	
		Driver Outputs Disabled					
I_{OSD}	Driver Short-Circuit Output Current	$V_O = -7\text{V}^{(3)}$			-250	mA	
		$V_O = +12\text{V}^{(3)}$			+250	mA	
I_{OSR}	Receiver Short-Circuit Output Current	$V_O = 0\text{V}$	-15		-85	mA	

Switching Characteristics
 $V_{CC} = 5.0\text{V}$, $T_A = 25^{\circ}\text{C}$

Symbol	Parameter	Conditions	Min	Typ	Max	Units
t_{PLH}	Driver Input to Output	$R_{L\text{DIFF}} = 60\ \Omega$		12	22	ns
t_{PHL}	Driver Input to Output	$C_{L1} = C_{L2} = 100\ \text{pF}$		17	22	ns
t_r	Driver Rise Time	$R_{L\text{DIFF}} = 60\ \Omega$			18	ns
t_f	Driver Fall Time	$C_{L1} = C_{L2} = 100\ \text{pF}$ (Figure 4 and Figure 6)			18	ns
t_{ZH}	Driver Enable to Output High	$C_L = 100\ \text{pF}$ (Figure 5 and Figure 7) S1 Open		29	100	ns
t_{ZL}	Driver Enable to Output Low	$C_L = 100\ \text{pF}$ (Figure 5 and Figure 7) S2 Open		31	60	ns
t_{LZ}	Driver Disable Time from Low	$C_L = 15\ \text{pF}$ (Figure 5 and Figure 7) S2 Open		13	30	ns
t_{HZ}	Driver Disable Time from High	$C_L = 15\ \text{pF}$ (Figure 5 and Figure 7) S1 Open		19	200	ns
t_{PLH}	Receiver Input to Output	$C_L = 15\ \text{pF}$ (Figure 3 and Figure 8)		30	37	ns
t_{PHL}	Receiver Input to Output	S1 and S2 Closed		32	37	ns
t_{ZL}	Receiver Enable to Output Low	$C_L = 15\ \text{pF}$ (Figure 3 and Figure 9) S2 Open		15	20	ns
t_{ZH}	Receiver Enable to Output High	$C_L = 15\ \text{pF}$ (Figure 3 and Figure 9) S1 Open		11	20	ns
t_{LZ}	Receiver Disable from Low	$C_L = 15\ \text{pF}$ (Figure 3 and Figure 9) S2 Open		28	32	ns
t_{HZ}	Receiver Disable from High	$C_L = 15\ \text{pF}$ (Figure 3 and Figure 9) S1 Open		13	35	ns

AC TEST CIRCUITS

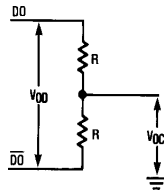
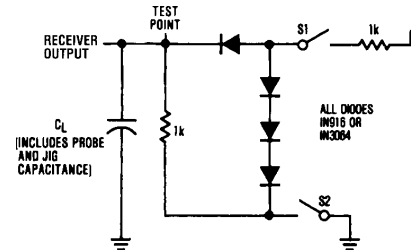

Figure 2.



Note: S1 and S2 of load circuit are closed except as otherwise mentioned.

Figure 3.

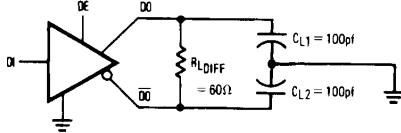
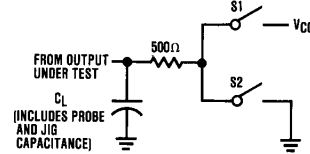

Figure 4.



Note: Unless otherwise specified the switches are closed.

Figure 5.

Switching Time Waveforms

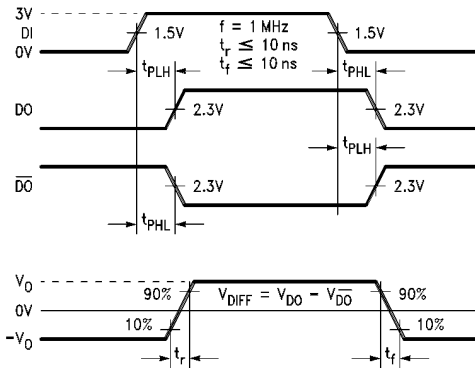

Figure 6. Driver Propagation Delays and Transition Times

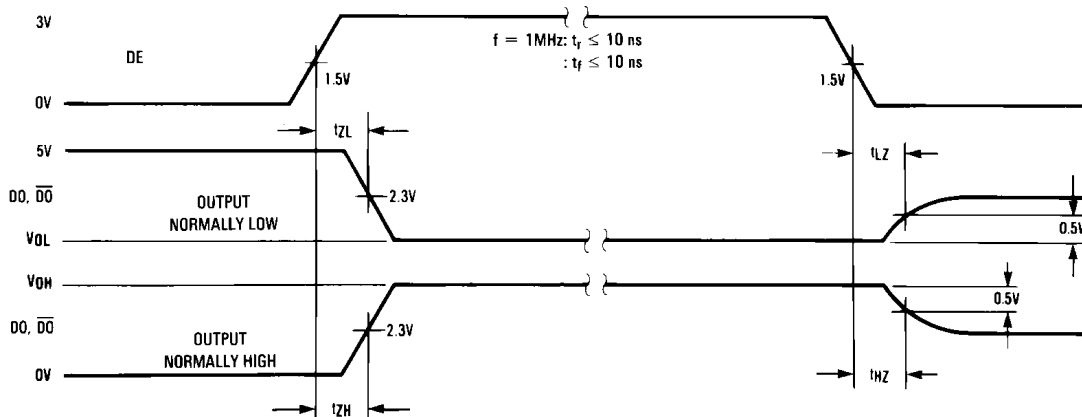
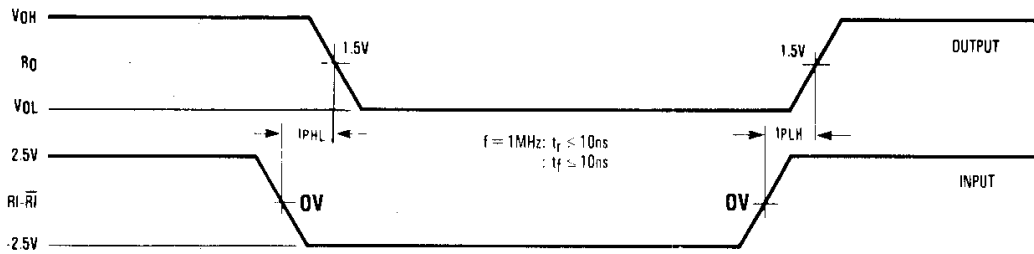

Figure 7. Driver Enable and Disable Times



Note: Differential input voltage may be realized by grounding \overline{RI} and pulsing RI between +2.5V and -2.5V

Figure 8. Receiver Propagation Delays

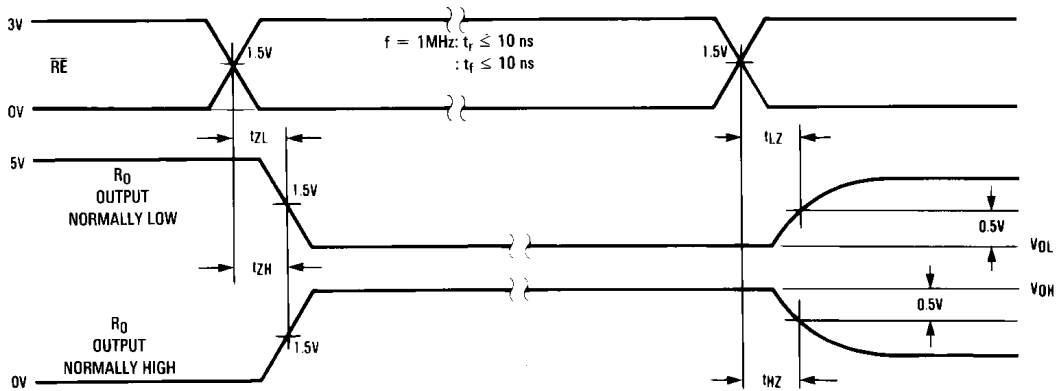

Figure 9. Receiver Enable and Disable Times

Function Tables

Table 1. SN75176B Transmitting⁽¹⁾

Inputs			Line Condition	Outputs	
\overline{RE}	DE	DI		\overline{DO}	DO
X	1	1	No Fault	0	1
X	1	0	No Fault	1	0
X	0	X	X	Z	Z
X	1	X	Fault	Z	Z

- (1) X — Don't care condition
 Z — High impedance state
 Fault — Improper line conditions causing excessive power dissipation in the driver, such as shorts or bus contention situations
 **This is a fail safe condition

Table 2. SN75176B Receiving⁽¹⁾

Inputs			Outputs
\overline{RE}	DE	$RI-\overline{RI}$	RO
0	0	$\geq +0.2V$	1
0	0	$\leq -0.2V$	0
0	0	Inputs Open**	1
1	0	X	Z

- (1) X — Don't care condition
 Z — High impedance state
 Fault — Improper line conditions causing excessive power dissipation in the driver, such as shorts or bus contention situations
 **This is a fail safe condition

SOP 8

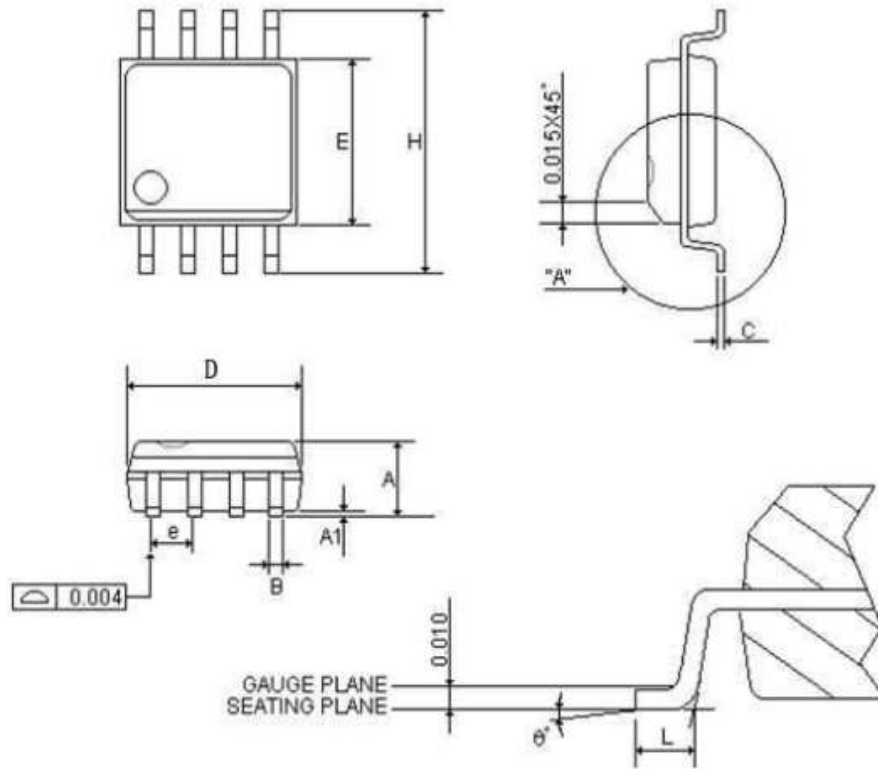

SYMBOLS	MIN	NOR	MAX	MIN	NOR	MAX
	(inch)			(mm)		
A	0.058	0.064	0.068	1.4732	1.6256	1.7272
A1	0.004	-	0.010	0.1016	-	0.254
B	0.013	0.016	0.020	0.3302	0.4064	0.508
C	0.0075	0.008	0.0098	0.1905	0.2032	0.2490
D	0.186	0.191	0.196	5.9944	6.1214	6.1976
E	0.150	0.154	0.157	3.81	3.9116	3.9878
e	-	0.050	-	-	1.27	-
H	0.228	0.236	0.244	5.7912	5.9944	6.1976
L	0.015	0.025	0.050	0.381	0.635	1.27
0°	0°	-	8°	0°	-	8°