

# CERAMIC SURFACE MOUNT MICROPROCESSOR CRYSTAL



7.0 x 5.0 x 1.3 mm

ABMM



RoHS  
Compliant

## FEATURES:

- Suitable for RoHS reflow
- Low height 1.3 mm max
- AT-strip cut offers a tight tolerance & stability

## APPLICATIONS:

- Computers, Modems, Microprocessors
- Communication, Test equipment
- PCMCIA

## STANDARD SPECIFICATIONS:

PARAMETERS	
ABRACON P/N	ABMM
Frequency Range	6.0 MHz to 125 MHz
Operation Mode	AT-cut 6.0 MHz ~ 33.0 MHz (Fundamental: Standard) 33.01 MHz - 125 MHz (Third-Overtone: Standard) 33.01 MHz ~ 50.0 MHz (Fundamental: Please specify. See options)
Operating Temperature	- 10°C to + 60°C (see options)
Storage Temperature	- 40°C to + 85°C
Frequency Tolerance at +25°C	± 50 ppm max. (see options)
Frequency Stability over the Operating Temp. (Ref to +25°C)	± 50 ppm max. (see options)
Equivalent Series Resistance	See Table 1
Shunt Capacitance C <sub>0</sub>	7pF max.
Load Capacitance C <sub>L</sub>	18pF (see options)
Drive Level	500µW max., 100µW typical
Aging at 25°C (first year)	± 5ppm max.
Insulation Resistance	500MΩ min at 100Vdc ± 15V

TABLE 1: STANDARD ESR

Frequency (MHz)	ESR (Ω) Max	Frequency (MHz)	ESR (Ω) Max
6.000 - 11.999(Fund)	70	20.000 - 50.000(Fund)	40
12.000 - 20.000(Fund)	50	33.000 - 125.00(3rd O/T)	80

## OPTIONS & PART IDENTIFICATION:

(Left blank if standard)

ABMM - [ ] MHz - [ ] - R [ ] - [ ] - [ ] - [ ] - [ ]

**Frequency in MHz**  
e.g. 6.000MHz  
14.31818MHz  
26.000MHz

**Load Capacitance**  
Please specify CL (8 to 33pF) in pF or S for Series  
Please contact ABRACON for other values

**ESR if other than STD**  
Specify a value in Ω

**Operating Temp.**  
E: 0°C ~ +70°C  
B: -20°C ~ +70°C  
C: -30°C ~ +70°C  
N: -30°C ~ +85°C  
D: -40°C ~ +85°C

**Freq. Tolerance**  
1: ± 10 ppm  
7: ± 15 ppm  
2: ± 20 ppm  
3: ± 25 ppm  
4: ± 30 ppm

**Freq. Stability**  
U: ± 10 ppm (\*)  
G: ± 15 ppm (\*\*)  
X: ± 20 ppm  
W: ± 25 ppm  
Y: ± 30 ppm  
H: ± 35 ppm

**Packaging**  
Blank: Bulk  
T: Tape & Reel (1k)  
T2: Tape & Reel (250)

**Mode**  
F: Fund.AT for >33MHz

\* -10 to +60°C only.  
\*\* Option E, B, and 10 to +60°C only.



# CERAMIC SURFACE MOUNT MICROPROCESSOR CRYSTAL



7.0 x 5.0 x 1.3 mm

ABMM



RoHS  
Compliant

## OUTLINE DRAWING:

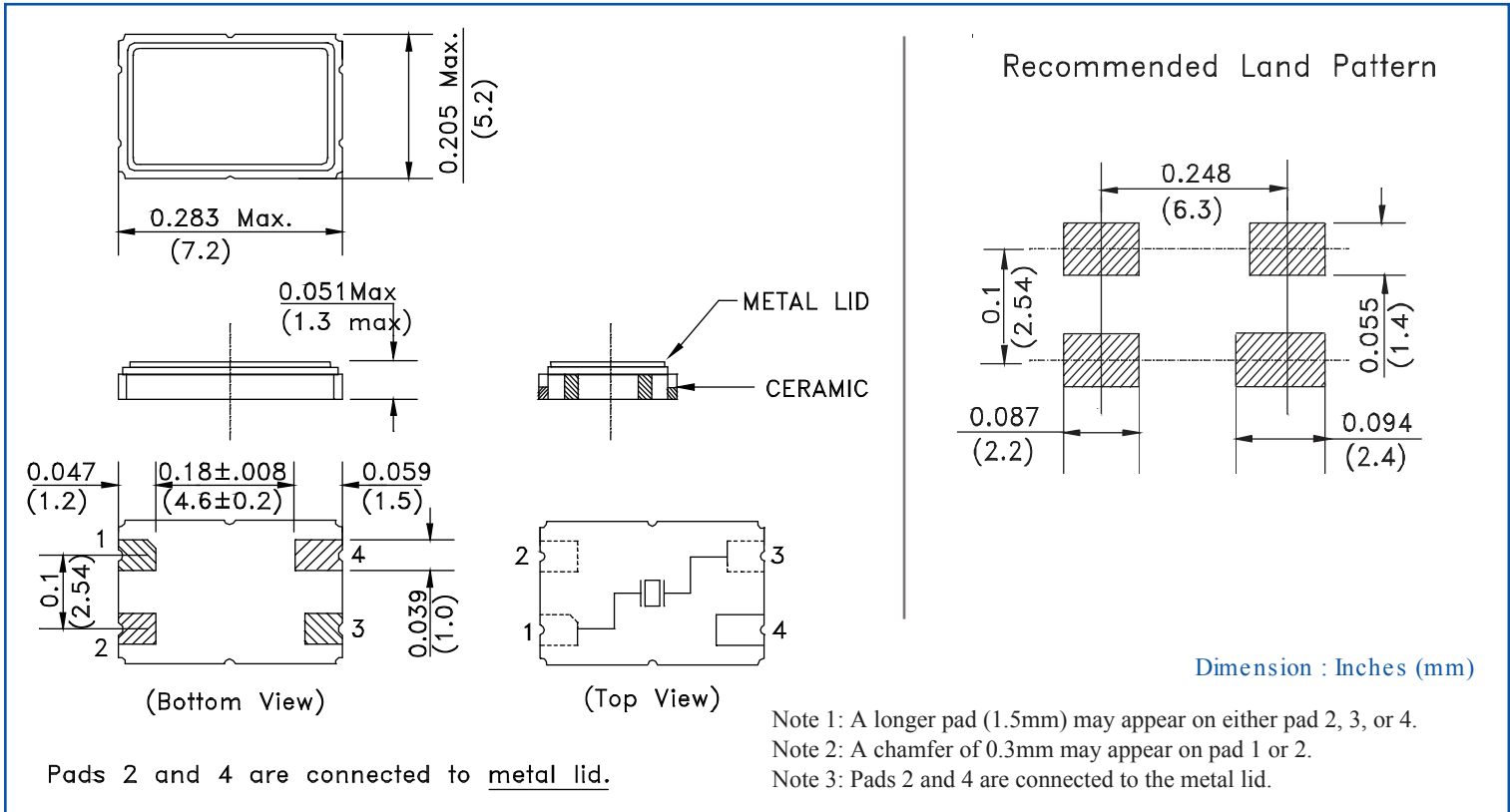

## TAPE & REEL:

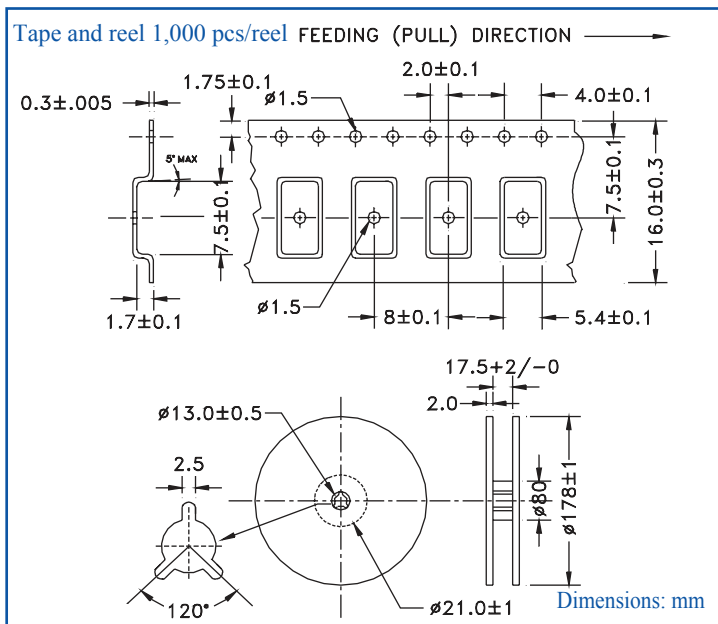

## REFLOW PROFILE:

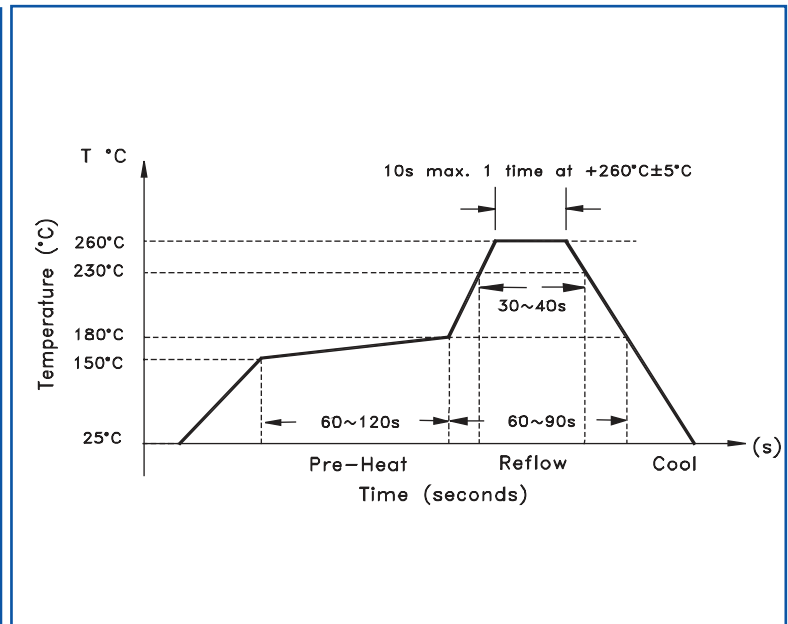

Need a test socket for the ABMM Series? To view compatible **PRECISION TEST & BURN-IN SOCKETS** for these parts, [click here](#).

**ATTENTION** Abracon Corporation's products are COTS- Commercial-Off-The-Shelf products; suitable for Commercial, Industrial and, where designated, Automotive Applications. Abracon's products are not specifically designed for Military, Aviation, Aerospace, Life-dependant Medical applications or any application requiring high reliability where component failure could result in loss of life and/or property. For applications requiring high reliability and/or presenting an extreme operating environment, written consent and authorization from Abracon Corporation is required. Please contact Abracon Corporation for more information.

ABRACON IS  
ISO9001:2008  
CERTIFIED



Visit [www.abracon.com](http://www.abracon.com) for Terms & Conditions of Sale  
30332 Esperanza, Rancho Santa Margarita, California 92688  
tel 949-546-8000 | fax 949-546-8001 | [www.abracon.com](http://www.abracon.com)

Revised: 02.26.12