

PRODUCT NUMBER
10087119-YXXLF

LATCHING _____
0= WITHOUT LATCH
1= STANDARD LATCH
2= LOW PROFILE LATCH

RoHS COMPATIBLE, SEE NOTE 9

PIN STYLE SEE SHEET 2

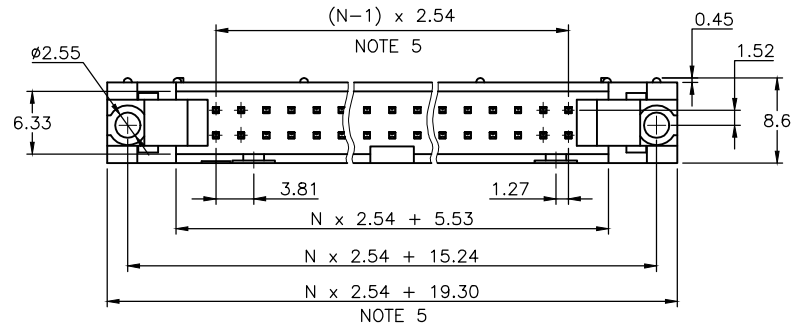

NOTES:

- 1 - HOUSING MAT'L : GLASS FILLED THERMOPLASTIC. UL94V-0 COLOR: GREY
- 2 - PIN MATERIAL : BRASS
- 3 - PRODUCT PACKAGED IN TUBES
- 4 - 40N MIN LATCH RETENTION FORCE AT FIRST EXTRACTION
- 5 - TO DETERMINE DIMENSIONS :
N = NUMBER OF POSITIONS PER ROW
EXAMPLE : 8 POS N x 2.54 = 20.32mm
- 6 - NO CENTRAL SLOT ON POSITIONS 6 & 8
- 7 - NO LEFT POLARIZATION ON POSITIONS 06, 08, 10, 14.
- 8 - NO GROOVE ON POSITIONS 06, 08, 10, 14, 30, 34
- 9 - RoHS COMPATIBLE PRODUCT SPECIFICATIONS
 - a - PLATING:
- "LF" MEANS THE PRODUCT IS LEAD-FREE, 2µm MINIMUM MATTE TIN OVER 1.27µm MINIMUM NICKEL UNDERPLATE.
 - b - MANUFACTURING PROCESS COMPATIBILITY
- THE HOUSING WILL WITHSTAND EXPOSURE TO 260°C ±5°C SOLDER BATH TEMPERATURE FOR 5 SECONDS IN A WAVE SOLDER APPLICATION WITH A 1.6mm MIN THICK CIRCUIT BOARD.
 - c - LABELING:
- MEETS PACKAGING SPECS AS PER GS-14-920
 - d - LEGAL STATEMENT: SEE GS-47-0004

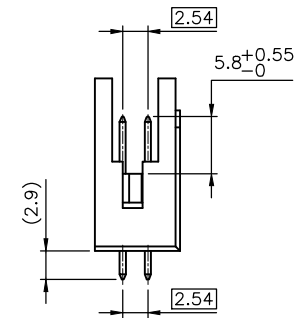
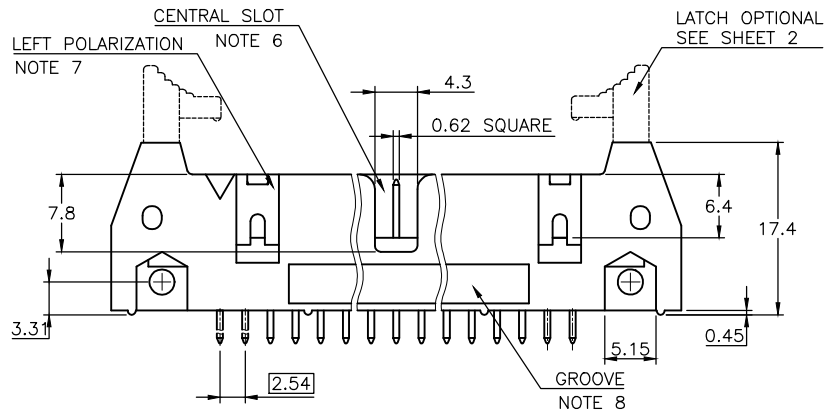

mat'l. code		surface		tolerance		projection		product family	
		ISO 1302 ✓		ISO 406 ISO 1101		mm		QUICKIE	
ltr		ecn no		dr		date		title	
A		F08-0149		LMU		08.03.27		QKIE HEADER	
B		-20412		BVE		15.03.10		STR 0.05µm Au	
								scale 2:1	
				dr		J.COMPAGNON		08.03.07	
				enr		L.MULIN		08.03.07	
				chr					
				appd		L.MULIN		08.03.07	
sheet index		revision sheet		B		A		dwg no	
				1		2		sheet 1 of - size	
								10087119 A3	
								type	
								CUSTOMER Drawing	

PIN STYLE	SIZE
06	2x3
08	2x4
10	2x5
14	2x7
16	2x8
18	2x9
20	2x10
26	2x13
30	2x15
34	2x17
40	2x20
44	2x22
50	2x25
60	2x30
64	2x32

PLATING :
0.05µm Au FULL PLATED
OVER 1.27µm Ni MIN

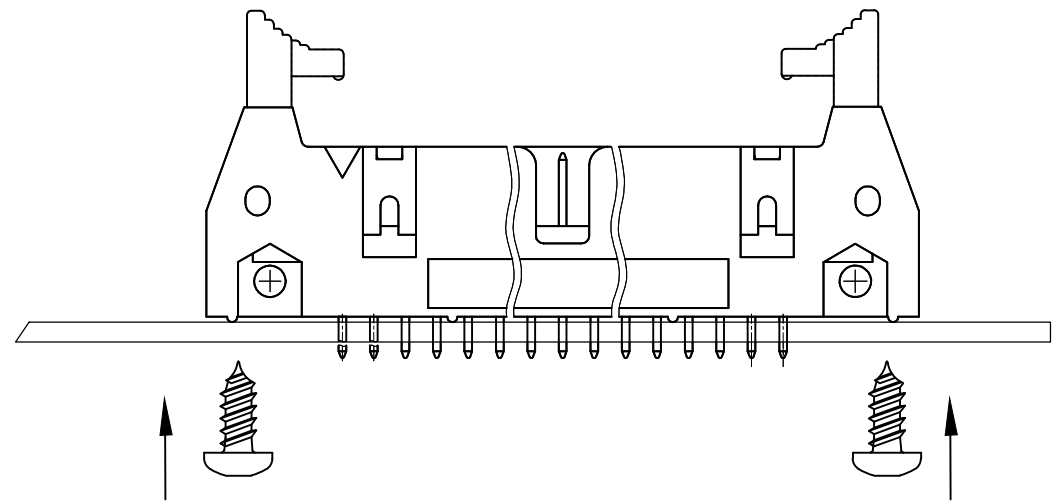

WHEN THE CONNECTORS NEED TO BE FIXED ON THE PCB'S
THE STAINLESS SCREWS REF TC POZI DIN7981 Ø2.9 X 6.5MM
TO BE USED

LATCHING FEATURES :

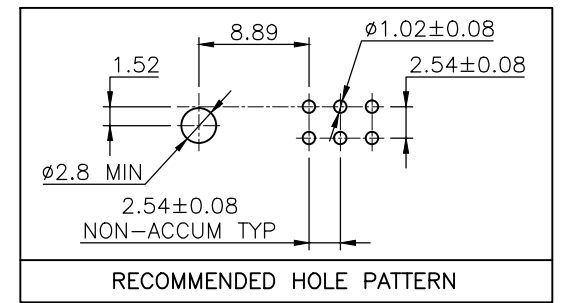
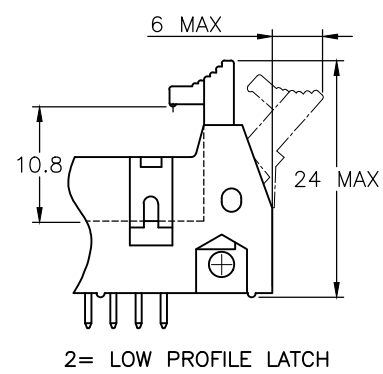
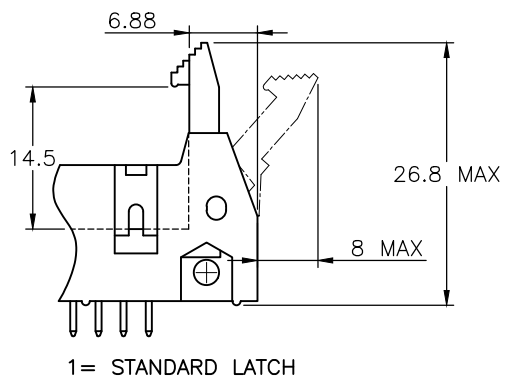

mat'l. code		surface ISO 1302 ✓		tolerance ISO 406 ISO 1101		projection mm		product family QUICKIE	
ltr ecn no dr date		tolerances unless otherwise specified		angles linear		scale 2:1		title QKIE HEADER STR 0.05µm Au	
A	B-20412	BVE	15.03.10	.X	±0.3			dwg no 10087119	
				.XX	±0.13			sheet 2 of A3	
				.XXX	±0.05			type CUSTOMER Drawing	
dr B.VERNIER 15.03.10		enr J.COMPAGNON 15.03.10		chr L.MULIN 15.03.10		appd L.MULIN 15.03.10		FCJ	
sheet index	revision sheet								



Copyright FCJ