

LTC3315A

3.3V V_{IN} , Dual 2A, 2MHz Buck Regulators at 1.2V and 1.8V Outputs in a 74mm² Solution

DESCRIPTION

Demonstration Circuit DC3123A features the [LTC3315A](#) dual 5V, 2A Synchronous Step-Down DC/DC regulators operating at 2MHz. One regulator provides a 1.2V output and the other provides 1.8V, both up to a 2A load. The LTC3315A supports adjustable output voltages from 0.5V to V_{IN} , operating frequencies from 1MHz up to 3MHz. The LTC3315A is a compact, high efficiency, and high speed synchronous monolithic step-down switching regulator. Fast minimum on-time of 25ns enables high V_{IN} to low V_{OUT} conversion at high frequency.

The DC3123A operating mode may be selected as Burst Mode operation, Skip mode or Forced Continuous (FC) mode. Setting JP1 to the FC/SYNC position will allow

the LTC3315A to sync to a clock frequency from 1MHz to 3MHz. The LTC3315A operates in Forced Continuous mode when syncing to an external clock.

The LTC3315A data sheet gives a complete description of the device, operation and application information. The data sheet must be read in conjunction with this demo. The LTC3315A is assembled in a 1.6mm × 1.6mm WLCSP package.

The Efficiency vs Load graph shows the efficiency and the power loss of the circuit with a 3.3V input in Burst Mode operation.

[Design files for this circuit board are available.](#)

All registered trademarks and trademarks are the property of their respective owners.

PERFORMANCE SUMMARY Specifications are at $T_A = 25^\circ\text{C}$

PARAMETER	CONDITIONS	MIN	TYP	MAX	UNITS
Input Supply Range (V_{IN})		2.25		5.5	V
Internal Oscillator Frequency (f_{SW})		1.9	2.0	2.1	MHz
Top Switch On Time			25		ns
V_{OUT1}	0 to 2A		1.2		V
V_{OUT2}	0 to 2A		1.8		V

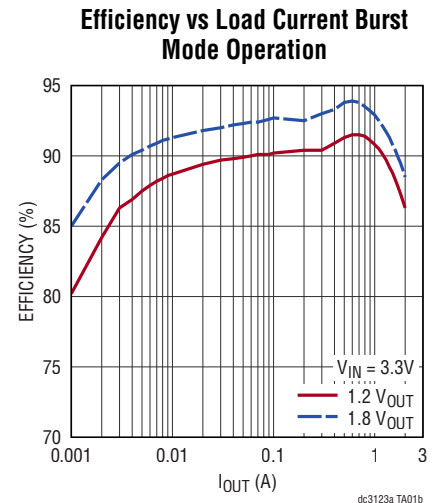
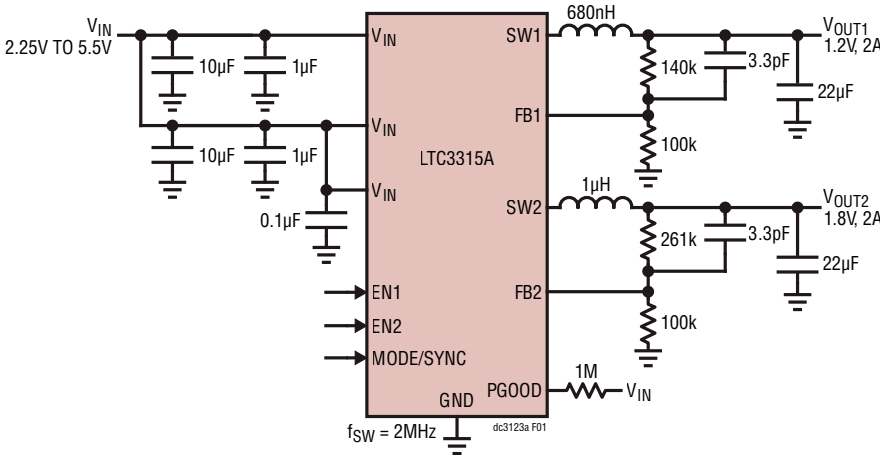

DEMO MANUAL DC3123A

BOARD PHOTO

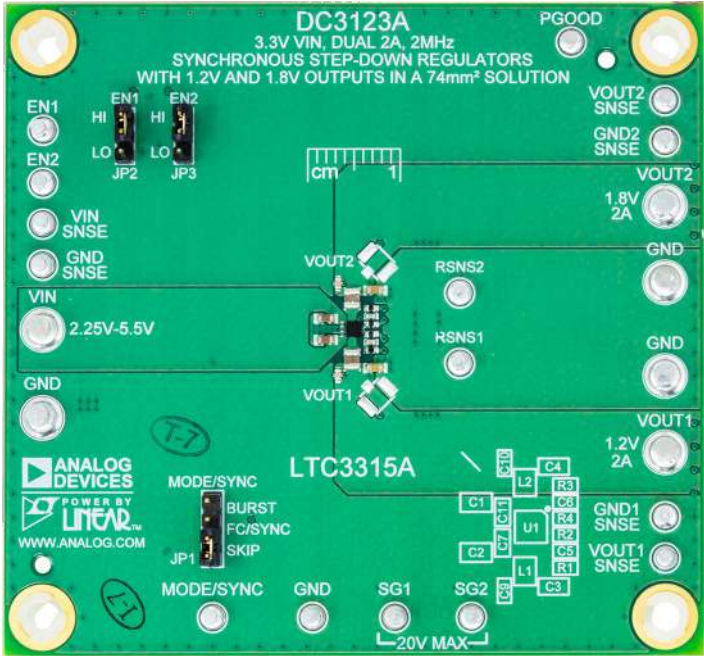

BOARD PERFORMANCE

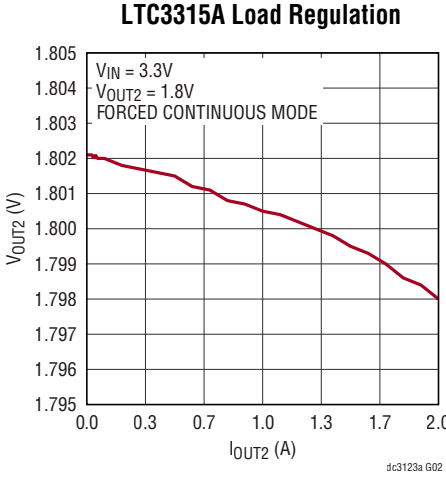
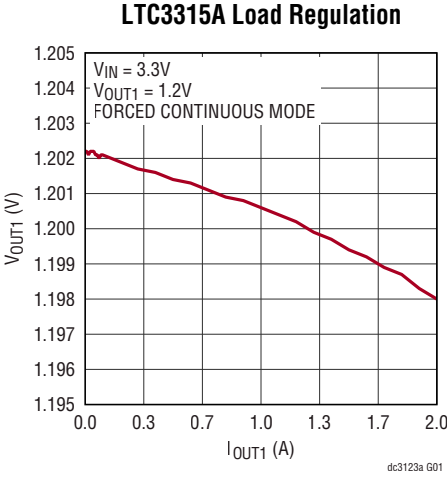

BOARD PERFORMANCE

**1.2V Load Transient Response
Forced Continuous Mode**

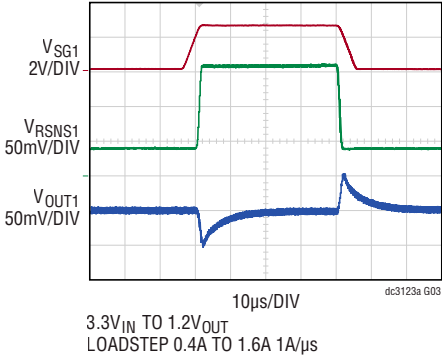

**1.8V Load Transient Response
Forced Continuous Mode**

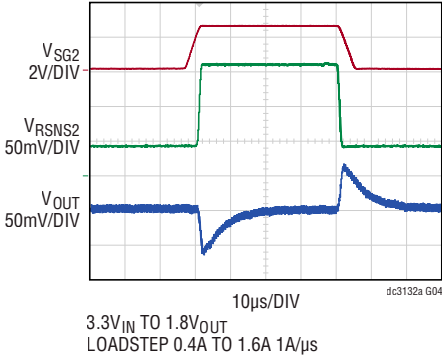

QUICK START PROCEDURE

The DC3123A is easy to set up to evaluate the performance of the LTC3315A. Refer to Figure 1 and Figure 2 for proper measurement equipment setup and follow the evaluation procedure below.

NOTE: For accurate V_{IN} , V_{OUT} and efficiency measurements, measure V_{IN} at the V_{IN} SNSE and GND SNSE turrets and V_{OUT} at the V_{OUT} SNSE and GND SNSE turrets as illustrated as VM1, VM2 and VM3 in Figure 1. When measuring the input or output voltage ripple, care must be taken to avoid a long ground lead on the oscilloscope probe.

1. Set the JP2 and JP3 jumpers on the DC3123A board to the HI position.
2. Set the JP1 jumper on the DC3123A board to the desired position, BURST for best efficiency, FC/SYNC for lowest ripple, and PS for a compromise between the two.
3. With power off, connect 0V to 6V, 5A power supply, PS1, between V_{IN} and GND with a series ammeter and a voltmeter as shown in Figure 1.
4. Turn on and set the PS1 input power supply to 3.3V and observe that V_{OUT1} regulates to 1.2V and V_{OUT2} regulates to 1.8V.

NOTE: Make sure that the input voltage does not exceed 6V.

5. With power off, connect a 0A to 2A load to V_{OUT1} and GND with a series ammeter and a voltmeter as shown in Figure 1.
6. Turn on LOAD1 and slowly increase from 0A to 2A and observe the output voltage. The output ripple may also be observed using an oscilloscope with the probe connected as shown in Figure 2.

NOTE: Measure the output voltage ripple by touching the probe tip directly across the output turrets or to TP1 as shown in Figure 2. TP1 is designed for a 50 Ω coax cable to reduce any high frequency noise that might couple into the oscilloscope probes.

7. Set LOAD1 to 500mA.
8. With power off, connect a second 0A to 2A load to V_{OUT2} and GND with a series ammeter and a voltmeter as shown in Figure 1.

9. Turn on LOAD2 and slowly increase the from 0A to 2A and observe the output voltage. The output ripple may also be observed using an oscilloscope with the probe connected as shown in Figure 2.
10. Momentarily short V_{OUT1} to ground with a clip lead and observe that the voltage on PGOOD drops to 0V.
11. To change the operating frequency of the LTC3315A, an external clock must be used. To do this set the JP1 jumper on the DC3123A board to the FC/SYNC position.
12. Set a pulse generator to output a 0V to 3.3V pulse at 2MHz, 50% duty cycle and connect it to the MODE/SYNC terminal and GND.
13. Change the frequency of the pulse generator from 2MHz to 3MHz and observe how observe how the frequency of SW1 follows the pulse generator.
14. Set LOAD1 greater than 1.0A. With an oscilloscope probe on SW1, remove the pulse signal to the MODE/SYNC terminal and observe how the switch frequency settles from 3MHz back to 2MHz.
15. To test the transient response with a base load, turn off LOADx (LOAD1 or LOAD2) and add the desired resistor to produce a minimum load between V_{OUTx} and RSNSx turrets (RL shown on Figure 1). Note that the total load resistance will be RL plus RSNSx (100m Ω).
16. Adjust a signal generator with a 10ms period, 10% duty cycle and an amplitude from 1V to 2V to start. Measure the RSNSx voltage to observe the current, $V_{RSNSx}/100m\Omega$. Adjust the amplitude of the pulse to provide the desired transient. Adjust the rising and falling edge of the pulse to provide the desired ramp rate. Refer to the following equations, the LTC3315A DC3123A transient plots and Figure 3.
$$I_{OUTx} = V_{RSNSx}/100m\Omega$$
$$V_{RSNSx} = V_{SGx} - V_{GSx}$$
Observe load transient effect on V_{OUTx}
17. Refer to the LTC3315A data sheet for more details on how the LTC3315A operates.
18. When done, turn off all loads, signal generator and power supplies.

QUICK START PROCEDURE

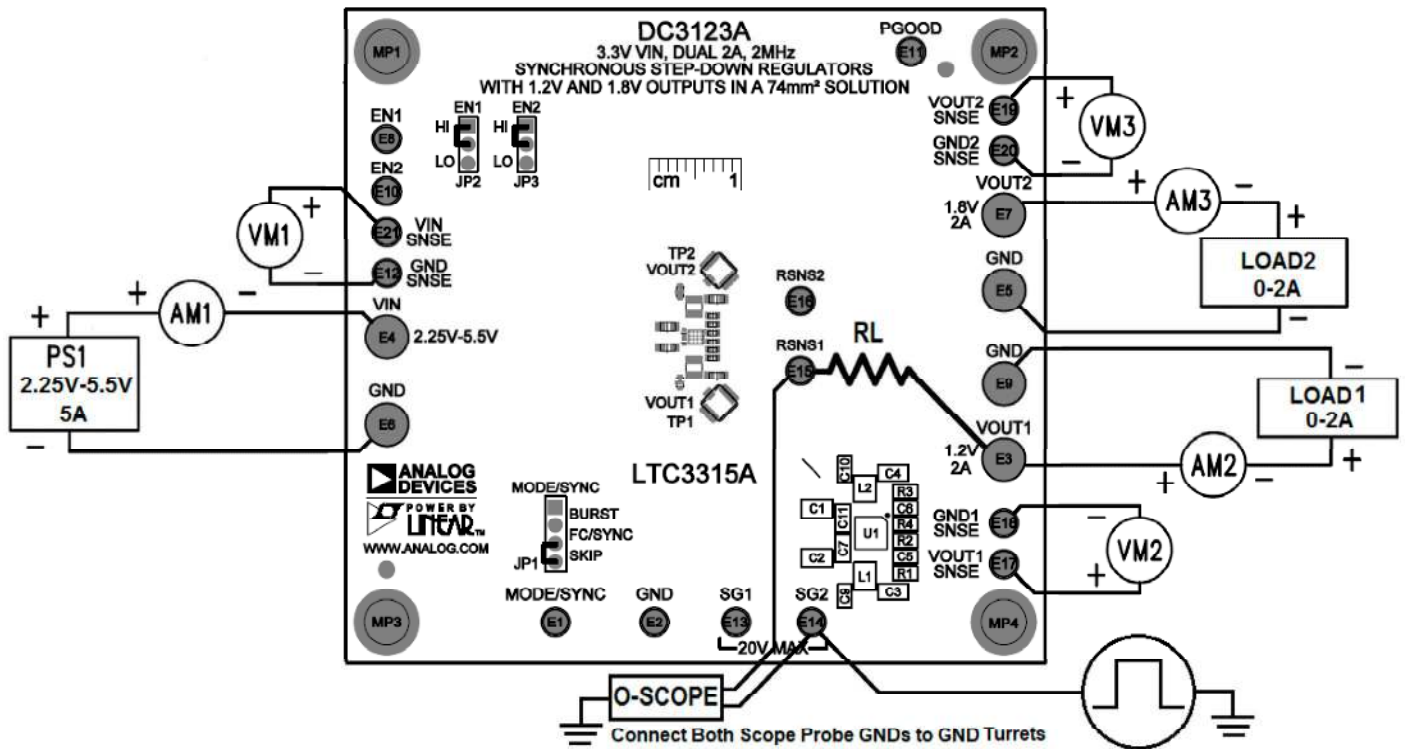

Figure 1. Proper Measurement Equipment Setup

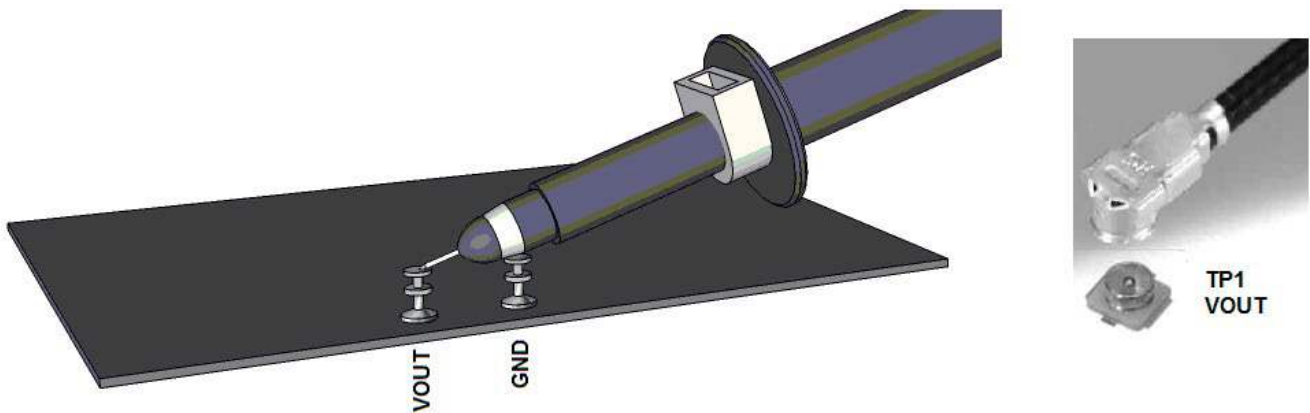

Figure 2. Measuring Input or Output Ripple

QUICK START PROCEDURE

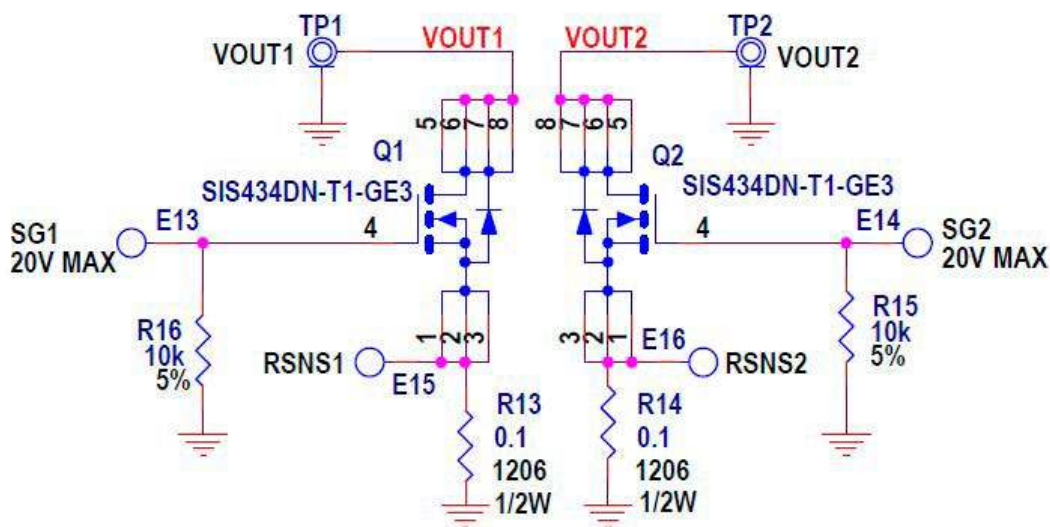

Figure 3. Optional Transient Response Circuit

THEORY OF OPERATION

Introduction to the DC3123A

The DC3123A demonstration circuit features the LTC3315A, a 5V Dual 2A Low voltage Synchronous Step-Down regulator. The LTC3315A is a monolithic, constant frequency, current mode step-down DC/DC converter. An internal oscillator turns on the internal top power switch at the beginning of each clock cycle. Current in the inductor then increases until the top switch comparator trips and turns off the top power switch. If the EN pin is low, the LTC3315A is in shutdown and in a low quiescent current state. When the EN pin is above its threshold, the switching regulator will be enabled. Buck 1 and Buck 2 are 180° out of phase with each other.

The MODE/SYNC pin sets the switching mode to pulse skip, forced continuous, or burst mode. If an external 1MHz to 3MHz clock is connected to the MODE/SYNC turret while the JP1 is set to the FC/SYNC position, the LTC3315A switching frequency will sync to the external clock while operating in forced continuous mode. See the LTC3315A data sheet for more detailed information.

The maximum allowable operating frequency is influenced by the minimum on time of the top switch, the ratio of V_{OUT} to V_{IN} and the available inductor values. The maximum allowable operating frequency may be calculated using a minimum T_{on} of 45ns in the formula below.

$$f_{SWMAX} = \frac{V_{OUT}}{V_{INMAX} \cdot T_{onMIN}}$$

Select an operating switching frequency below f_{SWMAX} . The LTC3315A has a requirement that the magnitude of the ripple current in the output inductor be greater than 0.6A peak to peak. This will determine the maximum inductor value for the application.

Accurately Measuring Output Ripple of the LTC3315A

With the fast edge rates of the circuit, high frequency noise can be observed when measuring the output voltage with 1MΩ terminated oscilloscope probes. To better view the output ripple with oscilloscopes of 400MHz bandwidth and above a 50Ω coax cable connected as close to the output caps as possible should be used with the

THEORY OF OPERATION

oscilloscope channel terminated to 50Ω at the scope. This will help to reduce the noise coupling onto and displaying on the scope. The demo board is set up to solder an U.FL,RECEPT,ST SMD,0Hz to 6GHz 50Ω connector (TP1) near the output cap C3 & C4. These pads can also be used to solder a coax cable or other oscilloscope probe connector if desired.

The DC3123A uses 3-terminal capacitors, C9 and C10, on the output to reduce the high frequency spikes that can be observed with high bandwidth oscilloscopes.

The high frequency spikes are partially attributed to the interwinding capacitance of the inductor and the voltage step is partially attributed to the inductance in the output capacitors. The step can be reduced by choosing low ESL capacitors as close to the inductor as possible. The high frequency spikes are reduced with using a small low ESL 3-terminal capacitor with the self-resonant frequency close to the high frequency spikes. Below is the output ripple using a 500MHz scope, 50Ω probe measured at TP1 without the 3-terminal capacitor populated in C9.

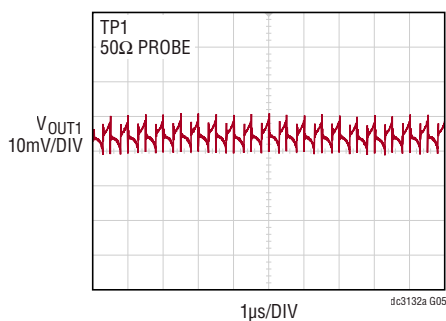

$V_{IN} = 3.3V$
 $V_{OUT1} = 1.2V$
 $I_{OUT1} = 2A$
 $C9 = 1nF$ 3-TERMINAL CAP

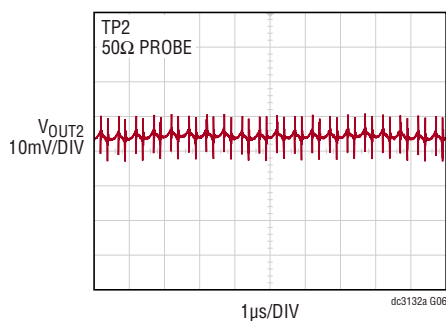

$V_{IN} = 3.3V$
 $V_{OUT2} = 1.8V$
 $I_{OUT2} = 2A$
 $C10 = 1nF$ 3-TERMINAL CAP

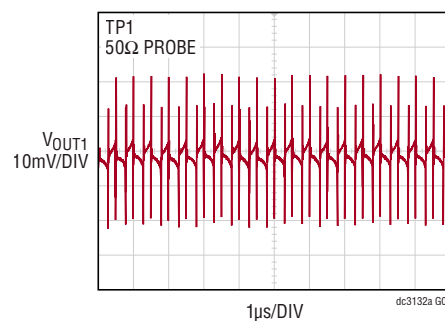

$V_{IN} = 3.3V$
 $V_{OUT1} = 1.2V$
 $I_{OUT1} = 2A$
 $C9 = OPEN$

DEMO MANUAL DC3123A

PARTS LIST

ITEM	QTY	REFERENCE	PART DESCRIPTION	MANUFACTURER/PART NUMBER
Required Circuit Components				
1	2	C1, C2	CAP., 10uF, X5R, 10V, 10%, 0603	MURATA, GRM188R61A106KAALD
2	2	C3, C4	CAP., 22uF, X5R, 10V, 20%, 0603	SAMSUNG, CL10A226MP8NUNE
3	2	C5, C6	CAP., 3.3pF, C0G, 50V, +/-0.25pF, 0402	AVX, 04025A3R3CAT2A
4	2	C7, C11	CAP., 1uF, X7T, 6.3V, 20%, 0201	MURATA, GRM033D70J105ME01D
5	1	C12	CAP., 0.1uF, X5R, 25V, 10%, 0402	AVX, 04023D104KAT2A
6	1	L1	IND., 680nH, FIXED, 20%, 3.5A, 0.033 OHMS, 0806	MURATA, DFE201612E-R68M=P2
7	1	L2	IND., 1uH, POWER, 20%, 2.9A, 48mOHMS, 0806	MURATA, DFE201612E-1R0M=P2
8	1	R1	RES., 140k OHMS, 1%, 1/16W, 0402, AEC-Q200	VISHAY, CRCW0402140KFKED
9	2	R2, R4	RES., 100k OHMS, 1%, 1/16W, 0402, AEC-Q200	VISHAY, CRCW0402100KFKED
10	1	R3	RES., 261k OHMS, 1%, 1/16W, 0402, AEC-Q200	VISHAY, CRCW0402261KFKED
11	1	U1	IC, DUAL 5V, 2A SYNCHRONOUS STEP-DOWN DC/DCs IN 1.6mm x 1.6mm WLCSP	ANALOG DEVICES, LTC3315AECBZ-R7#PBF
Additional Demo Board Circuit Components				
1	1	C8	CAP., 220uF, TANT. POSCAP, 6.3V, 20%, 7343, 18mOHMS, TPE	PANASONIC, 6TPE220MI
2	2	C9, C10	CAP., 1000pF, X7R, 50V, 20%, 0402, 3-TERM, X2Y EMI FILTER	JOHANSON DIELECTRICS, 500X07W102MV4T
3	2	Q1, Q2	XSTR., MOSFET, N-CH, 40V, 35A, PowerPAK 1212-8	VISHAY, SIS434DN-T1-GE3
4	2	R5, R11	RES., 249k OHMS, 1%, 1/16W, 0402, AEC-Q200	VISHAY, CRCW0402249KFKED
5	2	R6, R7	RES., 20 OHMS, 1%, 1/16W, 0402, AEC-Q200	VISHAY, CRCW040220R0FKED
6	1	R8	RES., 10k OHMS, 5%, 1/16W, 0402, AEC-Q200	VISHAY, CRCW040210K0JNED
7	2	R9, R10	RES., 1M OHM, 1%, 1/16W, 0402, AEC-Q200	VISHAY, CRCW04021M00FKED
8	1	R12	RES., 1M OHM, 5%, 1/16W, 0402, AEC-Q200	VISHAY, CRCW04021M00JNED
9	2	R13, R14	RES., 0.1 OHM, 1%, 1/2W, 1206, SENSE, AEC-Q200	IRC, LRC-LR1206LF-01-R100-F
10	2	R15, R16	RES., 10k OHMS, 5%, 1/10W, 0402, AEC-Q200	PANASONIC, ERJ2GEJ103X
Hardware: For Demo Board Only				
1	15	E1, E2, E8, E10-E21	TEST POINT, TURRET, 0.064" MTG. HOLE, PCB 0.062" THK	MILL-MAX, 2308-2-00-80-00-00-07-0
2	6	E3-E7, E9	TEST POINT, TURRET, 0.094" MTG. HOLE, PCB 0.062" THK	MILL-MAX, 2501-2-00-80-00-00-07-0
3	1	JP1	CONN., HDR, MALE, 1x4, 2mm, VERT, ST, THT	WURTH ELEKTRONIK, 62000411121
4	2	JP2, JP3	CONN., HDR, MALE, 1x3, 2mm, VERT, ST, THT	WURTH ELEKTRONIK, 62000311121
5	4	MP1-MP4	STANDOFF, NYLON, SNAP-ON, 0.25" (6.4mm)	KEYSTONE, 8831
6	0	TP1, TP2	CONN., U.FL, RECEPT, ST SMD, 0Hz to 6GHz 500hm	HIROSE ELECTRIC, U.FL-R-SMT-1(10)
7	3	XJP1-XJP3	CONN., SHUNT, FEMALE, 2 POS, 2mm	WURTH ELEKTRONIK, 60800213421

SCHEMATIC DIAGRAM

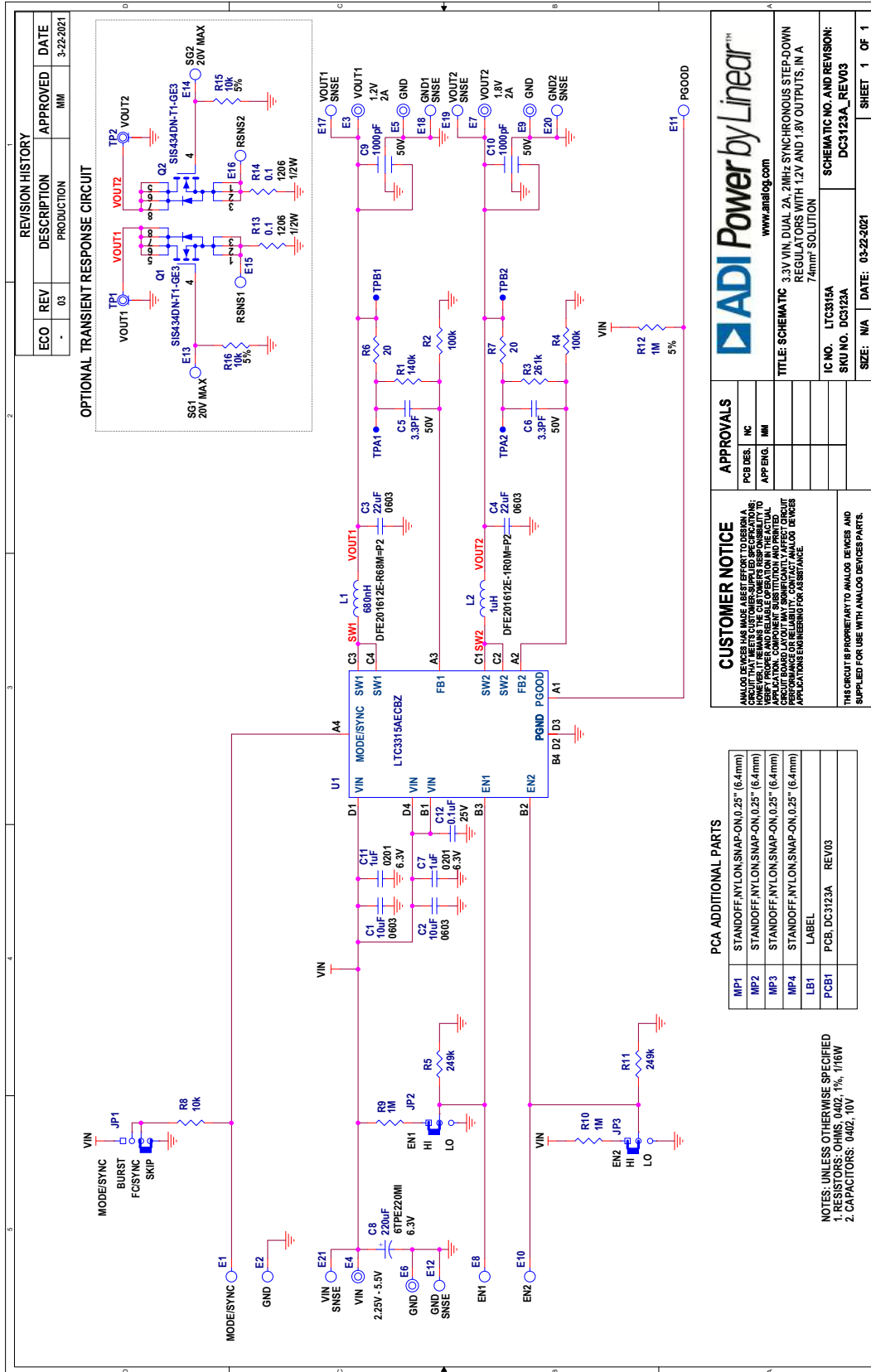

REVISION HISTORY				
ECO	REV	DESCRIPTION	APPROVED	DATE
-	03	PRODUCTION	MM	3-22-2021

OPTIONAL TRANSIENT RESPONSE CIRCUIT

ADI Power by Linear™
www.analog.com

CUSTOMER NOTICE
ANALOG DEVICES HAS MADE BEST EFFORT TO DESIGN A BOARD THAT MEETS THE CUSTOMER'S REQUIREMENTS. HOWEVER, THE BOARD IS PROVIDED AS A REFERENCE DESIGN. IT IS THE CUSTOMER'S RESPONSIBILITY TO VERIFY PROPER AND RELIABLE OPERATION IN THE ACTUAL APPLICATION. ANALOG DEVICES DOES NOT WARRANT PERFORMANCE OR RELIABILITY. CONTACT YOUR SALES REPRESENTATIVE FOR ASSISTANCE.

APPROVALS

PCB DES.	MM
APP. ENG.	MM

TITLE: SCHEMATIC 3.3V VIN, DUAL 2A, 2MHz SYNCHRONOUS STEP-DOWN REGULATORS WITH 1.2V AND 1.8V OUTPUTS, IN A 74mm² SOLUTION

IC NO.: LTC3315A
SKU NO.: DC3123A
SIZE: N/A
DATE: 03-22-2021

SCHEMATIC NO. AND REVISION: DC3123A_REV03

THIS CIRCUIT IS PROPRIETARY TO ANALOG DEVICES AND SUPPLIED FOR USE WITH ANALOG DEVICES PARTS.

SHEET 1 OF 1

PCA ADDITIONAL PARTS

MP1	STANDOFF, NYLON, SNAP-ON, 0.25" (6.4mm)
MP2	STANDOFF, NYLON, SNAP-ON, 0.25" (6.4mm)
MP3	STANDOFF, NYLON, SNAP-ON, 0.25" (6.4mm)
MP4	STANDOFF, NYLON, SNAP-ON, 0.25" (6.4mm)
LB1	LABEL
PCB1	PCB, DC3123A REV03

NOTES: UNLESS OTHERWISE SPECIFIED
1. RESISTORS: OHMS, 0402, 1%, 1/16W
2. CAPACITORS: 0402, 10V





ESD Caution

ESD (electrostatic discharge) sensitive device. Charged devices and circuit boards can discharge without detection. Although this product features patented or proprietary protection circuitry, damage may occur on devices subjected to high energy ESD. Therefore, proper ESD precautions should be taken to avoid performance degradation or loss of functionality.

Legal Terms and Conditions

By using the evaluation board discussed herein (together with any tools, components documentation or support materials, the "Evaluation Board"), you are agreeing to be bound by the terms and conditions set forth below ("Agreement") unless you have purchased the Evaluation Board, in which case the Analog Devices Standard Terms and Conditions of Sale shall govern. Do not use the Evaluation Board until you have read and agreed to the Agreement. Your use of the Evaluation Board shall signify your acceptance of the Agreement. This Agreement is made by and between you ("Customer") and Analog Devices, Inc. ("ADI"), with its principal place of business at One Technology Way, Norwood, MA 02062, USA. Subject to the terms and conditions of the Agreement, ADI hereby grants to Customer a free, limited, personal, temporary, non-exclusive, non-sublicensable, non-transferable license to use the Evaluation Board FOR EVALUATION PURPOSES ONLY. Customer understands and agrees that the Evaluation Board is provided for the sole and exclusive purpose referenced above, and agrees not to use the Evaluation Board for any other purpose. Furthermore, the license granted is expressly made subject to the following additional limitations: Customer shall not (i) rent, lease, display, sell, transfer, assign, sublicense, or distribute the Evaluation Board; and (ii) permit any Third Party to access the Evaluation Board. As used herein, the term "Third Party" includes any entity other than ADI, Customer, their employees, affiliates and in-house consultants. The Evaluation Board is NOT sold to Customer; all rights not expressly granted herein, including ownership of the Evaluation Board, are reserved by ADI. CONFIDENTIALITY. This Agreement and the Evaluation Board shall all be considered the confidential and proprietary information of ADI. Customer may not disclose or transfer any portion of the Evaluation Board to any other party for any reason. Upon discontinuation of use of the Evaluation Board or termination of this Agreement, Customer agrees to promptly return the Evaluation Board to ADI. ADDITIONAL RESTRICTIONS. Customer may not disassemble, decompile or reverse engineer chips on the Evaluation Board. Customer shall inform ADI of any occurred damages or any modifications or alterations it makes to the Evaluation Board, including but not limited to soldering or any other activity that affects the material content of the Evaluation Board. Modifications to the Evaluation Board must comply with applicable law, including but not limited to the RoHS Directive. TERMINATION. ADI may terminate this Agreement at any time upon giving written notice to Customer. Customer agrees to return to ADI the Evaluation Board at that time. LIMITATION OF LIABILITY. THE EVALUATION BOARD PROVIDED HEREUNDER IS PROVIDED "AS IS" AND ADI MAKES NO WARRANTIES OR REPRESENTATIONS OF ANY KIND WITH RESPECT TO IT. ADI SPECIFICALLY DISCLAIMS ANY REPRESENTATIONS, ENDORSEMENTS, GUARANTEES, OR WARRANTIES, EXPRESS OR IMPLIED, RELATED TO THE EVALUATION BOARD INCLUDING, BUT NOT LIMITED TO, THE IMPLIED WARRANTY OF MERCHANTABILITY, TITLE, FITNESS FOR A PARTICULAR PURPOSE OR NON-INFRINGEMENT OF INTELLECTUAL PROPERTY RIGHTS. IN NO EVENT WILL ADI AND ITS LICENSORS BE LIABLE FOR ANY INCIDENTAL, SPECIAL, INDIRECT, OR CONSEQUENTIAL DAMAGES RESULTING FROM CUSTOMER'S POSSESSION OR USE OF THE EVALUATION BOARD, INCLUDING BUT NOT LIMITED TO LOST PROFITS, DELAY COSTS, LABOR COSTS OR LOSS OF GOODWILL. ADI'S TOTAL LIABILITY FROM ANY AND ALL CAUSES SHALL BE LIMITED TO THE AMOUNT OF ONE HUNDRED US DOLLARS (\$100.00). EXPORT. Customer agrees that it will not directly or indirectly export the Evaluation Board to another country, and that it will comply with all applicable United States federal laws and regulations relating to exports. GOVERNING LAW. This Agreement shall be governed by and construed in accordance with the substantive laws of the Commonwealth of Massachusetts (excluding conflict of law rules). Any legal action regarding this Agreement will be heard in the state or federal courts having jurisdiction in Suffolk County, Massachusetts, and Customer hereby submits to the personal jurisdiction and venue of such courts. The United Nations Convention on Contracts for the International Sale of Goods shall not apply to this Agreement and is expressly disclaimed.