

# **Datasheet**

# **Raspberry PLC**

# **Family**

## Technical Features CONECTABLE PLC RASPBERRY PI 24Vcc

MODEL TYPE	Raspberry PLC
Input Voltage	12 to 24Vdc (Fuse protection (2.5A) Polarity protection)
Input rated voltage	24Vdc
Rated Power	30 W
I max.	15A
Size	101x70.1x119.5
SRAM	2/4/8 GB
Communications	I2C, Ethernet (x2), USB (x4), RS485 (x2), SPI, WiFi, Bluetooth, Serial TTL, CAN, microSD, RTC

## General Features

Power supply voltage	DC power supply	12 to 24Vdc
Operating voltage range	DC power supply	11.4 to 25.4Vdc
Power consumption	DC power supply	30 W MAX.
External power supply	Power supply voltage	24Vdc
	Power supply voltage	700 mA
Insulation resistance	20mΩ min.at 500Vdc between the AC terminals and the protective earth terminal.	
Dielectric strength	2.300 VAC at 50/60 Hz for one minute with a leakage current of 10mA max. Between all the external AC terminals and the protective ground terminal.	
Shock resistance	80m/s <sup>2</sup> in the X, Y and Z direction 2 times each.	
Ambient temperature (operating)	0° to 50°C with Raspberry OS Lite / 0° to 40°C with Raspberry OS Desktop	
Ambient humidity (operating)	10% to 90% (no condensation)	
Ambient environment (operating)	With no corrosive gas	
Ambient temperature (storage)	-20° to 60°C	
Power supply holding time	2ms min.	
Weight	378g max.	

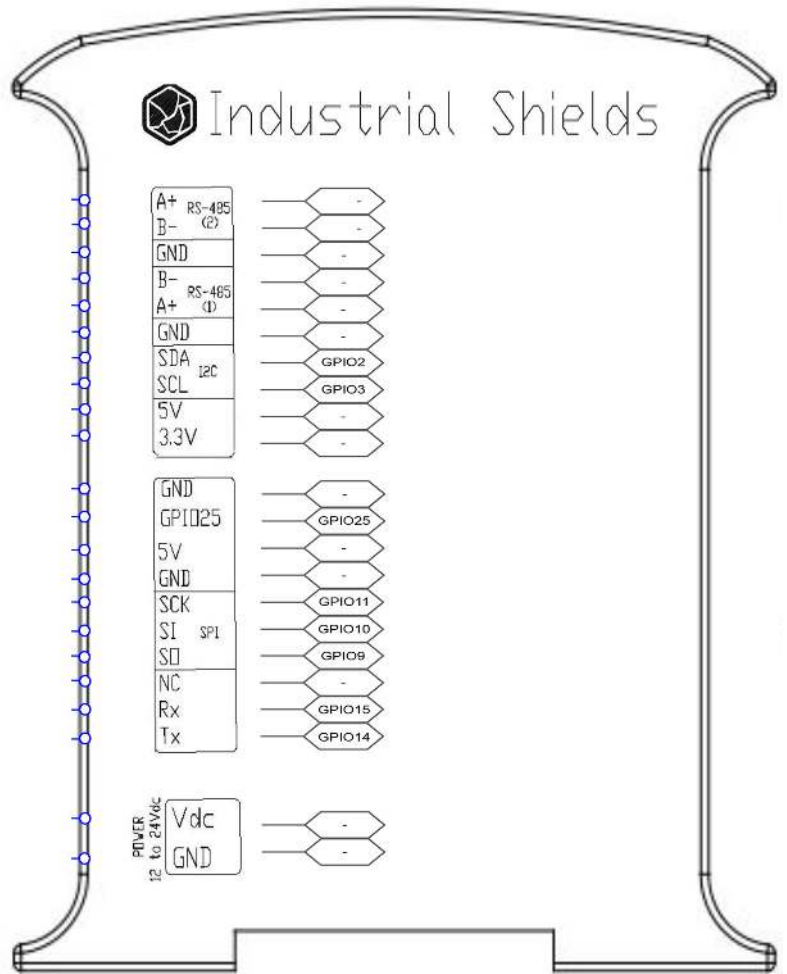

### **i** GPIO(x1)

Digital GPIO25 (3.3V)

#### Expandability

I2C - 127 elements  
(x2) ModbusRTU with RS485: 32 elements

### Upper Side 1



### Left side



### Upper side 2



### Right Side

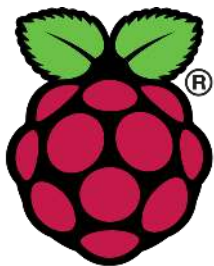

# Raspberry Pi

## I/Os Table

I/Os Table						
Model	Reference 2	Analog Input	Digital Isolated Input <sup>1</sup>	Digital Isolated Output	Digital/Analogic Output	Relay Output
Normal	01200X000000	0	1	0	0	0
21+	01200X000200	6	7	5	3	0
42+	01200X000400	12	14	10	6	0
58+	01200X000600	16	21	15	9	0
19R	01200X000100	4	2	0	3	8
38R	01200X000300	8	4	0	6	16
57R	01200X000500	12	8	0	9	24
38AR	01200X000700	10	9	5	6	8
53ARR	01200X000800	14	11	5	9	16
57AAR	01200X000900	16	16	10	9	8
54ARA	01200X001000	16	16	10	9	8
50RRA	01200X001100	14	11	5	9	16

## Reference Table

Reference Table				
Model	RAM Memory			Accessory with FAN
	2GB RAM	4GB RAM	8GB RAM	
<b>PLC Raspberry General Family</b>				
Raspberry PLC Ethernet CPU (Raspberry Pi 4B 2GB RAM Included + 8GB pSLC SIM W/Linux)	012002000400	012003000000	012004000000	xxxxxxxxxxxxF
Raspberry PLC Ethernet 21 I/Os Analog/Digital PLUS (Raspberry Pi 4B 2GB RAM Included + 8GB pSLC SIM W/Linux)	012002000600	012003000200	012004000200	xxxxxxxxxxxxF
Raspberry PLC Ethernet 42 I/Os Analog/Digital PLUS (Raspberry Pi 4B 2GB RAM Included + 8GB pSLC SIM W/Linux)	012002000100	012003000400	012004000400	xxxxxxxxxxxxF
Raspberry PLC Ethernet 58 I/Os Analog/Digital PLUS (Raspberry Pi 4B 2GB RAM Included + 8GB pSLC SIM W/Linux)	012002000300	012003000600	012004000600	xxxxxxxxxxxxF
Raspberry PLC Ethernet 19R I/Os Analog/Digital PLUS (Raspberry Pi 4B 2GB RAM Included + 8GB pSLC SIM W/Linux)	012002000500	012003000100	012004000100	xxxxxxxxxxxxF
Raspberry PLC Ethernet 38R I/Os Analog/Digital PLUS (Raspberry Pi 4B 2GB RAM Included + 8GB pSLC SIM W/Linux)	012002000700	012003000300	012004000300	xxxxxxxxxxxxF
Raspberry PLC Ethernet 57R I/Os Analog/Digital PLUS (Raspberry Pi 4B 2GB RAM Included + 8GB pSLC SIM W/Linux)	012002000800	012003000500	012004000500	xxxxxxxxxxxxF
Raspberry PLC Ethernet 38AR I/Os Analog/Digital PLUS (Raspberry Pi 4B 2GB RAM Included + 8GB pSLC SIM W/Linux)	012002000900	012003000700	012004000700	xxxxxxxxxxxxF
Raspberry PLC Ethernet 53ARR I/Os Analog/Digital PLUS (Raspberry Pi 4B 2GB RAM Included + 8GB pSLC SIM W/Linux)	012002001000	012003000800	012004000800	xxxxxxxxxxxxF
Raspberry PLC Ethernet 57AAR I/Os Analog/Digital PLUS (Raspberry Pi 4B 2GB RAM Included + 8GB pSLC SIM W/Linux)	012002001100	012003000900	012004000900	xxxxxxxxxxxxF
Raspberry PLC Ethernet 54ARA I/Os Analog/Digital PLUS (Raspberry Pi 4B 2GB RAM Included + 8GB pSLC SIM W/Linux)	012002001100	012003001000	012004001000	xxxxxxxxxxxxF
Raspberry PLC Ethernet 50RRA I/Os Analog/Digital PLUS (Raspberry Pi 4B 2GB RAM Included + 8GB pSLC SIM W/Linux)	012002000000	012003001100	012004001100	xxxxxxxxxxxxF
<b>PLC Raspberry GPRS Family</b>				
Raspberry PLC Ethernet & GPRS (Raspberry Pi 4B 2GB RAM Included + 8GB pSLC SIM W/Linux)	016002000000	016003000000	016004000000	xxxxxxxxxxxxF
Raspberry PLC & GPRS 21 I/Os Analog/Digital PLUS (Raspberry Pi 4B 2GB RAM Included + 8GB pSLC SIM W/Linux)	016002000200	016003000200	016004000200	xxxxxxxxxxxxF
Raspberry PLC & GPRS 42 I/Os Analog/Digital PLUS (Raspberry Pi 4B 2GB RAM Included + 8GB pSLC SIM W/Linux)	016002000400	016003000400	016004000400	xxxxxxxxxxxxF
Raspberry PLC & GPRS 58 I/Os Analog/Digital PLUS (Raspberry Pi 4B 2GB RAM Included + 8GB pSLC SIM W/Linux)	016002000600	016003000600	016004000600	xxxxxxxxxxxxF
Raspberry PLC & GPRS 19R I/Os Analog/Digital PLUS (Raspberry Pi 4B 2GB RAM Included + 8GB pSLC SIM W/Linux)	016002000100	016003000100	016004000100	xxxxxxxxxxxxF
Raspberry PLC & GPRS 38R I/Os Analog/Digital PLUS (Raspberry Pi 4B 2GB RAM Included + 8GB pSLC SIM W/Linux)	016002000300	016003000300	016004000300	xxxxxxxxxxxxF
Raspberry PLC & GPRS 57R I/Os Analog/Digital PLUS (Raspberry Pi 4B 2GB RAM Included + 8GB pSLC SIM W/Linux)	016002000500	016003000500	016004000500	xxxxxxxxxxxxF
Raspberry PLC & GPRS 38AR I/Os Analog/Digital PLUS (Raspberry Pi 4B 2GB RAM Included + 8GB pSLC SIM W/Linux)	016002000700	016003000700	016004000700	xxxxxxxxxxxxF
Raspberry PLC & GPRS 53ARR I/Os Analog/Digital PLUS (Raspberry Pi 4B 2GB RAM Included + 8GB pSLC SIM W/Linux)	016002000800	016003000800	016004000800	xxxxxxxxxxxxF
Raspberry PLC & GPRS 57AAR I/Os Analog/Digital PLUS (Raspberry Pi 4B 2GB RAM Included + 8GB pSLC SIM W/Linux)	016002000900	016003000900	016004000900	xxxxxxxxxxxxF
Raspberry PLC & GPRS 54ARA I/Os Analog/Digital PLUS (Raspberry Pi 4B 2GB RAM Included + 8GB pSLC SIM W/Linux)	016002001000	016003001000	016004001000	xxxxxxxxxxxxF
Raspberry PLC & GPRS 50RRA I/Os Analog/Digital PLUS (Raspberry Pi 4B 2GB RAM Included + 8GB pSLC SIM W/Linux)	016002001100	016003001100	016004001100	xxxxxxxxxxxxF

## Notes

- GPRS PLC's have one digital isolated input less than the Ethernet version.
- The X on the reference number shows the RAM Memory model. See the Reference Table. Example:
  - xxxxx2xxxxxx - 2GB RAM Memory
  - xxxxx3xxxxxx - 4GB RAM Memory
  - xxxxx4xxxxxx - 8GB RAM Memory

## I/Os Ranges

- Analogic I/Os voltage: 0 - 10 Vdc
- Digital I/Os voltage: 5 - 24 Vdc (300 mA)
- Relay's voltage: 220 Vac (5 A)

### Pinout equivalence

Raspberry Pinout	PLC Pinout
NC	-
GPIO2	SDA
GPIO3	SCL
GPIO4	INT21
GND	-
GPIO17	INT30
GPIO27	INT20
GPIO22	IRQ SPI 485
NC	-
GPIO10	MOSI 0
GPIO9	MISO 0
GPIO11	SCLK 0
GND	-
GPIO 0	-
GPIO5	IRQ SPI CAN
GPIO6	IRQ SPI ETH
GPIO13	INT10
GPIO19	MISO 1
GPIO26	FAN CONTROL
GND	-

Raspberry Pinout	PLC Pinout
5V	-
5V	-
GND	-
GPIO14	TX
GPIO15	RX
GPIO18	CS SPI1 485
GND	-
GPIO23	UPS CONTROL FROM RASPI
GPIO24	UPS CONTROL TO RASPI
GND	-
GPIO25	GPIO25
GPIO8	CS SPI0 CAN
GPIO7	CS SPI0 ETH
GPIO1	-
GND	-
GPIO12	INT11
GND	-
GPIO16	INT31
GPIO 20	MOSI 1
GPIO21	SCLK 1

### Internal Scheme

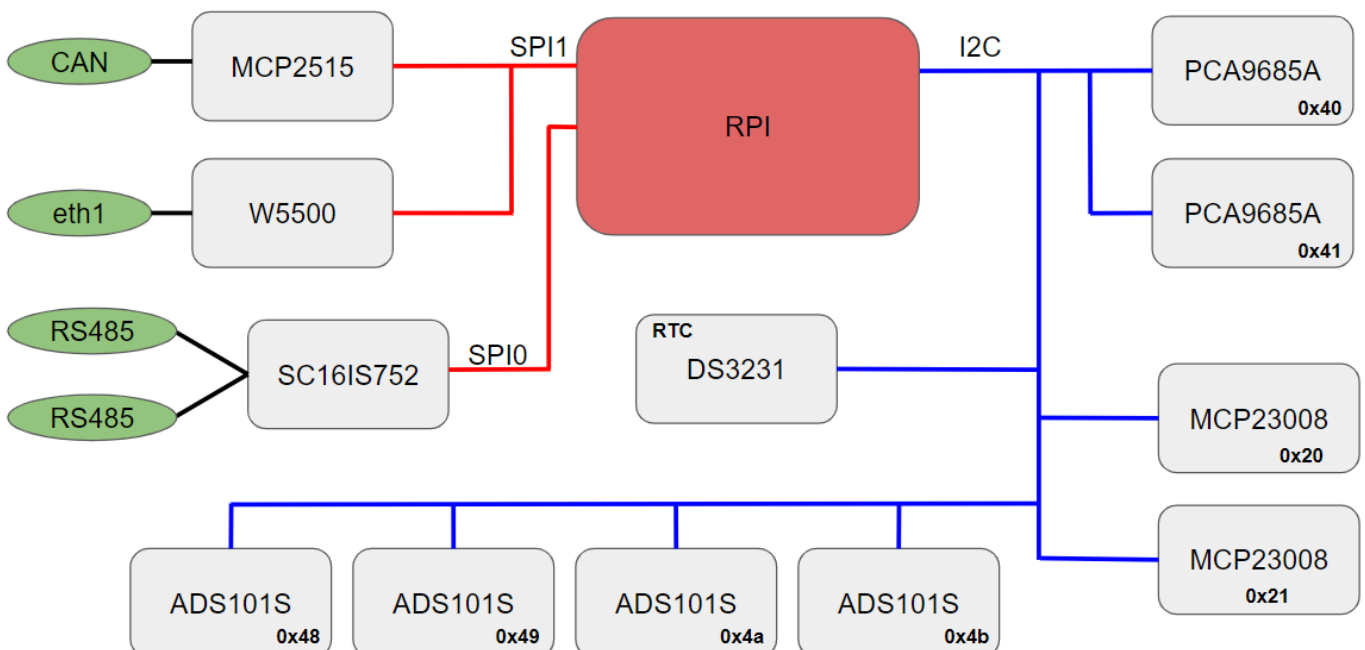

### Analog I/Os equivalence

Analog Inputs		
PLC Pinout	Chip ADDR	Chip INDEX
<b>Zone A</b>		
I0.7	0x4a	0
I0.8	0x4a	1
I0.9	0x4b	0
I0.10	0x48	2
I0.11	0x48	0
I0.12	0x48	1
<b>Zone B</b>		
I1.7	0x49	0
I1.8	0x4a	3
I1.9	0x4b	2
I1.10	0x4b	3
I1.11	0x4a	2
I1.12	0x49	1
<b>Zone C</b>		
I2.7	0x49	3
I2.8	0x49	2
I2.9	0x48	3
I2.10	0x4b	1

Analog Outputs		
PLC Pinout	Chip ADDR	Chip INDEX
<b>Zone A</b>		
A0.5	0x40	10
A0.6	0x40	1
A0.7	0x40	0
<b>Zone B</b>		
A1.5	0x40	3
A1.6	0x40	5
A1.7	0x40	8
<b>Zone C</b>		
A2.5	0x41	2
A2.6	0x41	1
A2.7	0x41	0

Digital Inputs			
PLC Pinout	Chip ADDR	Chip INDEX	GPIO
<b>Zone A</b>			
I0.0	ADDR = 0x21	5	-
I0.1	ADDR = 0x21	3	-
I0.2	ADDR = 0x21	2	-
I0.3	ADDR = 0x21	1	-
I0.4	ADDR = 0x21	0	-
I0.5	-	-	GPIO = 13
I0.6	-	-	GPIO = 12
<b>Zone B</b>			
I1.0	ADDR = 0x20	2	-
I1.1	ADDR = 0x20	1	-
I1.2	ADDR = 0x20	0	-
I1.3	ADDR = 0x21	7	-
I1.4	ADDR = 0x21	6	-
I1.5	-	-	GPIO = 27
I1.6	-	-	GPIO = 4
<b>Zone C</b>			
I2.0	ADDR = 0x20	6	-
I2.1	ADDR = 0x20	5	-
I2.2	ADDR = 0x20	7	-
I2.3	ADDR = 0x20	4	-
I2.4	ADDR = 0x20	3	-
I2.5	-	-	GPIO = 17
I2.6	-	-	GPIO = 16

Digital Outputs		
PLC Pinout	Chip ADDR	Chip INDEX
<b>Zone A</b>		
Q0.0	0x40	15
Q0.1	0x40	14
Q0.2	0x40	13
Q0.3	0x40	12
Q0.4	0x40	11
Q0.5	0x40	10
Q0.6	0x40	1
Q0.7	0x40	0
<b>Zone B</b>		
Q1.0	0x40	2
Q1.1	0x40	9
Q1.2	0x40	6
Q1.3	0x40	4
Q1.4	0x40	7
Q1.5	0x40	3
Q1.6	0x40	5
Q1.7	0x40	8
<b>Zone C</b>		
Q2.0	0x41	6
Q2.1	0x41	7
Q2.2	0x41	5
Q2.3	0x41	4
Q2.4	0x41	3
Q2.5	0x41	2
Q2.6	0x41	1
Q2.7	0x41	0

Relé I/Os equivalence

Analog Inputs		
PLC Pinout	Chip ADDR	Chip INDEX
<b>Zone A</b>		
I0.2	0x4a	0
I0.3	0x4a	1
I0.4	0x4b	0
I0.5	0x48	2
<b>Zone B</b>		
I1.2	0x49	0
I1.3	0x4a	3
I1.4	0x4b	2
I1.5	0x4b	3
<b>Zone C</b>		
I2.2	0x49	3
I2.3	0x49	2
I2.4	0x48	3
I2.5	0x4b	1

Analog Outputs		
PLC Pinout	Chip ADDR	Chip INDEX
<b>Zone A</b>		
A0.0	0x40	10
A0.1	0x40	1
A0.2	0x40	0
<b>Zone B</b>		
A1.0	0x40	3
A1.1	0x40	5
A1.2	0x40	8
<b>Zone C</b>		
A2.0	0x41	2
A2.1	0x41	1
A2.2	0x41	0

Digital Inputs	
PLC Pinout	GPIO
<b>Zone A</b>	
I0.0	13
I0.1	12
<b>Zone B</b>	
I1.0	27
I1.1	4
<b>Zone C</b>	
I2.0	17
I2.1	16

Digital Outputs		
PLC Pinout	Chip ADDR	Chip INDEX
<b>Zone A</b>		
Q0.0	0x40	10
Q0.1	0x40	1
Q0.2	0x40	0
<b>Zone B</b>		
Q1.0	0x40	3
Q1.1	0x40	5
Q1.2	0x40	8
<b>Zone C</b>		
Q2.0	0x41	2
Q2.1	0x41	1
Q2.2	0x41	0

## Relay I/Os equivalence

Relay		
PLC Pinout	Chip ADDR	Chip INDEX
<b>Zone A</b>		
R0.1	0x21	3
R0.2	0x21	5
R0.3	0x21	1
R0.4	0x21	2
R0.5	0x40	11
R0.6	0x40	12
R0.7	0x40	13
R0.8	0x40	14
<b>Zone B</b>		
R1.1	0x20	1
R1.2	0x20	2
R1.3	0x21	7
R1.4	0x20	0
R1.5	0x40	7
R1.6	0x40	4
R1.7	0x40	6
R1.8	0x40	9
<b>Zone C</b>		
R2.1	0x20	5
R2.2	0x20	6
R2.3	0x20	4
R2.4	0x20	7
R2.5	0x41	3
R2.6	0x41	4
R2.7	0x41	5
R2.8	0x41	7

## Performance Specifications

Raspberry Board	Raspberry Pi 4
I/O control method	Combination of the cyclic scan and immediate refresh processing methods.
Programming language	Linux applications: Python, C++, etc.
CPU	Broadcom BCM2711, Quad core Cortex-A72 (ARM v8) 64-bit SoC @ 1.5GHz
Website	<a href="https://www.raspberrypi.org/">https://www.raspberrypi.org/</a>

### Raspberry PLC Access

How to access to the Raspberry PLC:

-Linux users: using ssh specifying the IP address: 10.10.10.20/24.

-Windows users: we recommend to use PuTTY ssh client. The IP address have to be specified: 10.10.10.20/24.

You can download the latest release of PuTTY here:

<https://www.chiark.greenend.org.uk/~sgtatham/putty/latest.html>

#### UPS Shield

This PLC has integrated an UPS Shield, a device which provides an anti-voltage drop protection system designed to avoid data corruption when the current is suddenly cut off.

#### RTC

This PLC has integrated the DS3231 Real Time Clock model which is powered by a button battery (CR1216 or CR1220).

#### Fan

This PLC has the option to include a fan to refrigerate the CPU and the other components if the working environment requires it.

### Warnings



Unused pins should not be connected. Ignoring the directive may damage the controller.

Before using this product, it is the responsibility of the user to read the product's User Guide and all accompanying documentation.

Industrial Shields PLCs must be powered between 12Vdc and 24Vdc. If a higher voltage is supplied to the equipment can suffer irreversible damage.

Maintenance must be performed by qualified personnel familiarized with the construction, operation, and hazards involved with the control.

Maintenance should be performed with the control out of operation and disconnected from all sources of power.

The Industrial Shields Family PLCs are Open Type Controllers. It is required that you install the Raspberry PLC in a housing, cabinet, or electric control room. Entry to the housing, cabinet, or electric control room should be limited to authorized personnel.

Inside the housing, cabinet or electric control room, the Industrial Shields PLC must be at a minimum distance from the rest of the components of a minimum of 25 cm, it can be severely damaged.

Failure to follow these installation requirements could result in severe personal injury and/or property damage. Always follow these requirements when installing Raspberry family PLCs.









In case of installation or maintenance of the PLC please follow the instructions marked in the Installation and Maintenance section on the User Guide.

Do not disconnect equipment when a flammable or combustible atmosphere is present.

Disconnection of equipment when a flammable or combustible atmosphere is present may cause a fire or explosion which could result in death, serious injury and/or property damage.

Inside the encapsulated, there are supercapacitors if 25F which can be dangerous. Be careful with them.

## Symbology

	Indicates that the equipment is suitable for direct current only, to identify relevant terminals
	Indicates that the equipment is suitable for alternating current only, to identify relevant terminals
	To identify the control by which a pulse is started.
	To identify an earth (ground) terminal in cases where neither the symbol 5018 nor 5019 is explicitly required.
	To identify the switch by means of which the signal lamp(s) is (are) switched on or off.
	CE marking indicates that a product complies with applicable European Union regulations
	Indicates a potentially hazardous situation which, if not avoided, could result in death or serious injury
	To indicate hazards arising from dangerous voltages