

For Liquid & Gas

Head-separated Dual Display Digital Pressure Sensor

DPC-L100 SERIES DPH-L100 SERIES



DPC-L100 SERIES DPH-L100 SERIES



High-precision detection of fluid and air pressure

Allows high-precision fluid pressure management

The analog voltage output of the sensor head can achieve a high-precision sensing of $\pm 1\%$ F.S. (at a normal temperature of 23 °C 73.4 °F).

Oil-less single-layer diaphragm

Oil is not encapsulated in the diaphragm of the pressure sensing portion. No need to worry that oil will leak into the medium when the sensor head is damaged.

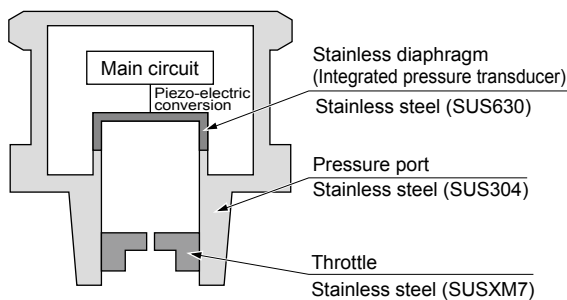

Compact stainless body

Compact size of HEX. 22 × 59 mm 0.866 × 2.323 in (excluding the screws). The body is also stainless so it can be used in various environments.



Strong against pressure surges from throttle loading

Controls pressure surges and reduces sensor failure.



Product line

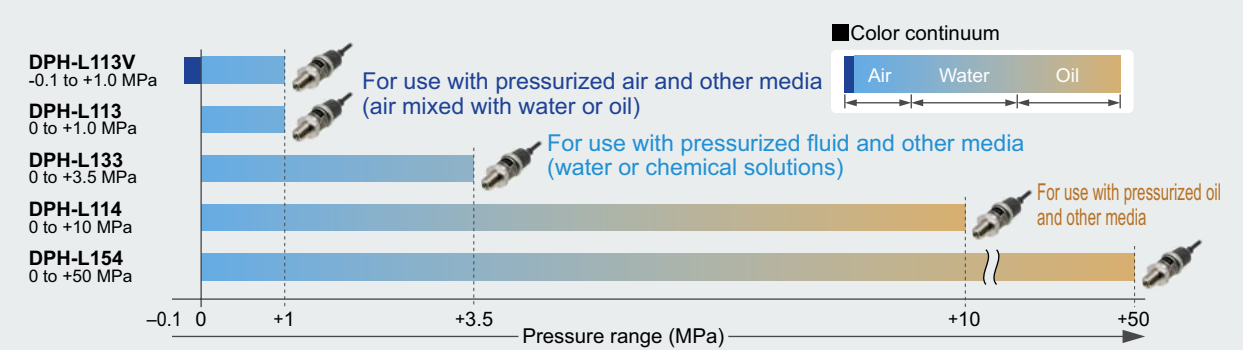

APPLICATIONS

Transport of glass sheets after washing
(Air pressure with waterdrops)



Management of plastic filling
machine pressure
(Fluid pressure)

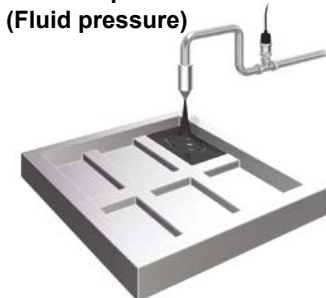

Management of press pressure
(Oil pressure)



The dual display means that the “current value” and the “threshold value”,
it makes direct setting of threshold value

Equipped with a 30 mm 1.181 in square compact-sized dual display. Because the current value and the threshold value can be checked at the same time, the threshold value can be set and checked smoothly without having to switch screen modes. ON/OFF operations are still carried out while the threshold values are being set, so setting to the same sensitivity as dial control-type sensors is possible. And naturally a key lock function is also equipped.



3-color display (Red, Green, Orange)

The main display changes color in line with changes in the status of output ON/OFF operation, and it also changes color while setting is in progress. The sensor status can therefore be understood easily, and operating errors can be reduced.

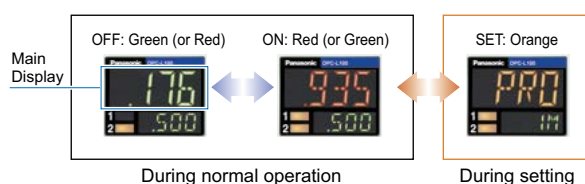

Equipped with new functions optimal for fluid pressure

Equipped with functions optimal for fluid pressure management while inheriting the operability of the **DP-100** series.

- Peak / Bottom hold (output-linked)

When output turns on (or off), the controller's digital display (current value) is reset and peak / bottom hold operation starts. For example, this functionality could be used to verify the peak pressure for an industrial press each time a workpiece is loaded.

- Current value hold

The controller's digital display (current value) is held while external input is on. By activating external input the moment you wish to capture the pressure value, you can pause and verify the display.

MOUNTING

Tight installation to panels is possible

An exclusive mounting bracket **MS-DP1-2** that is suitable for 1 to 6 mm 0.039 to 0.236 in panel thickness is available.



PRODUCT CONFIGURATION

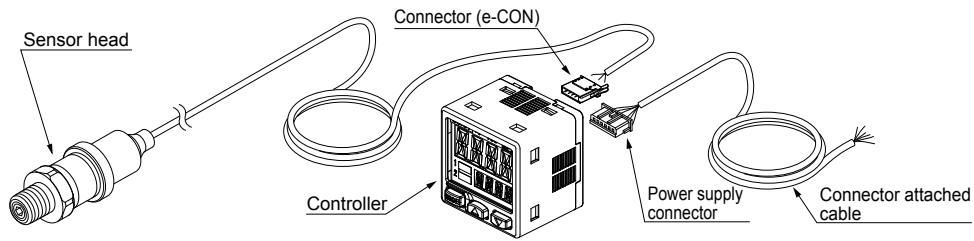

ORDER GUIDE

Sensor heads

| Type | Appearance | Rated pressure range | Model No. | Pressure port | Applicable fluid |
|-------------------|---|----------------------|------------------|------------------|--|
| Compound pressure |  | -0.1 to +1.0 MPa | DPH-L113V | R1/4 male thread | Gases and fluids that do not corrode stainless steel SUS304, SUS630, or SUSXM7 |
| Positive pressure | | 0 to +1.0 MPa | DPH-L113 | | |
| | | 0 to +3.5 MPa | DPH-L133 | | |
| | | 0 to +10 MPa | DPH-L114 | | |
| | | 0 to +50 MPa | DPH-L154 | | |

Controllers

| Appearance | Model No. | Comparative output |
|---|-------------------|-------------------------------|
|  | DPC-L101 | NPN open-collector transistor |
| | DPC-L101-P | PNP open-collector transistor |

* **CN-66A-C2**
(Connector attached cable 2 m 6.562 ft) is attached.

Type without connector attached cable

Type without connector attached cable is available. When ordering this type, suffix "-J" to the Model No. (e.g.) Type without connector attached cable of **DPC-L101-P** is "**DPC-L101-P-J**".

Accessory

- **CN-66A-C2** (Connector attached cable 2 m 6.562 ft)



OPTIONS

| Designation | Model No. | Description | |
|-------------------------------|--|--|--|
| Sensor head connector (e-CON) | CN-EP2 (Note 1) 5 pcs. per set | Connector for connecting sensor head controller | |
| Connector attached cable | CN-66A-C2 (Note 2) | Length 2 m 6.562 ft | Controller power supply I/O cable. 0.2 mm ² 6-core oil-resistant cabtyre cable with connector |
| | CN-66A-C5 | Length 5 m 16.404 ft | |
| Power supply connector | CN-66A 5 pcs. per set | Connector for controller power supply I/O cable. | |
| Controller mounting bracket | MS-DP1-6 | Allows sensors to be installed on the wall. Multiple sensors can also be mounted closely. | |
| Panel mounting bracket | MS-DP1-2 | Allows installation to panels with thickness of 1 to 6 mm 0.039 to 0.236 in. Multiple sensors can also be mounted closely. | |
| Front protection cover | MS-DP1-3 | Protects the adjustment surfaces of controllers. (Can be attached when using the panel mounting bracket) | |

Notes: 1) One is attached to each sensor head according to standard.

2) The connector attached cable **CN-66A-C2** is supplied with the controller according to standard.

Sensor head connector (e-CON)

- **CN-EP2**

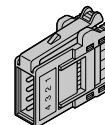

Note: One is attached to each sensor head according to standard.

Connector attached cable

- **CN-66A-C2**
- **CN-66A-C5**



Note: The connector attached cable **CN-66A-C2** is supplied with the controller according to standard.

Power supply connector

- **CN-66A**

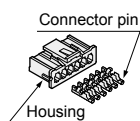
Controller mounting bracket

- **MS-DP1-6**

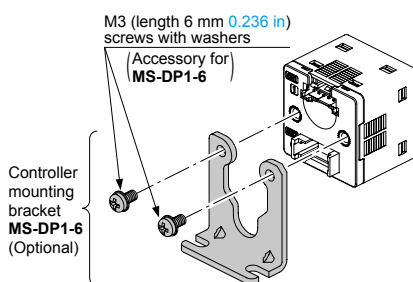
Panel mounting bracket, Front protection cover

- **MS-DP1-2**
- **MS-DP1-3**

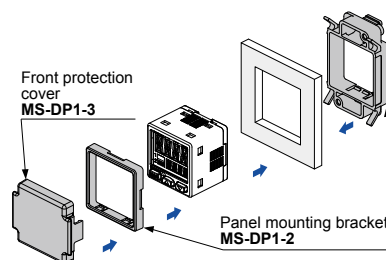
Recommended e-CON

Model No.: 1473562-4 (Manufactured by Tyco Electronics Japan G.K.)

Note: Contact the manufacturer for details of the recommended products.

Recommended power supply connector

Contact: SPHD-001T-P0.5, Housing: PAP-06V-S (Manufactured by J.S.T. Mfg. Co., Ltd.)

Note: Contact the manufacturer for details of the recommended products.

Recommended crimping tool

Model No.: YC-610R (Manufactured by J.S.T. Mfg. Co., Ltd.)

Note: Contact the manufacturer for details of the recommended products.

SPECIFICATIONS

Sensor heads

| Item | Type Model No. | Compound pressure | Positive pressure | | | |
|---------------------------------|--------------------------|---|-------------------|-----------------|--|-----------------|
| | | -0.1 to 1 MPa type | 1 MPa type | 3.5 MPa type | 10 MPa type | 50 MPa type |
| | | DPH-L113V | DPH-L113 | DPH-L133 | DPH-L114 | DPH-L154 |
| CE marking directive compliance | | EMC Directive, RoHS Directive | | | | |
| Type of pressure | | Sealed gauge pressure (Note 4) | | | | |
| Rated pressure range | | -0.1 to +1 MPa | 0 to +1 MPa | 0 to +3.5 MPa | 0 to +10 MPa | 0 to +50 MPa |
| Pressure withstandability | | 2 MPa | 2 MPa | 7 MPa | 20 MPa | 75 MPa |
| Applicable fluid | | Gases and fluids that do not corrode stainless steel SUS630, SUS304, or SUSXM7 | | | | |
| Supply voltage | | 9 to 36 V DC [9 to 32 V DC when using the attached connector (e-CON)] | | | | |
| Current consumption | | 20 mA or less | | | | |
| Analog voltage output | | Output voltage: 1 to 5 V DC (over rated pressure range) Accuracy: $\pm 1.0\%$ F.S. (at $+23 \pm 2\text{ }^\circ\text{C}$ $+73.4 \pm 35\text{ }^\circ\text{F}$) $\pm 2.0\%$ F.S. (at -20 to $+70\text{ }^\circ\text{C}$ -4 to $+158\text{ }^\circ\text{F}$) (including linearity, hysteresis and repeatability) | | | Output voltage: 1 to 5 V DC (over rated pressure range) Accuracy: $\pm 1.0\%$ F.S. (at $+23 \pm 2\text{ }^\circ\text{C}$ $+73.4 \pm 35\text{ }^\circ\text{F}$) $\pm 2.0\%$ F.S. (at -20 to $+125\text{ }^\circ\text{C}$ -4 to $+257\text{ }^\circ\text{F}$) (including linearity, hysteresis and repeatability) | |
| Response time | | 1 ms or less | | | | |
| Environmental resistance | Protection | IP67 (IEC) | | | | |
| | Ambient temperature | -20 to $+70\text{ }^\circ\text{C}$ -4 to $+158\text{ }^\circ\text{F}$ (No dew condensation or icing allowed), Storage: -30 to $+70\text{ }^\circ\text{C}$ -22 to $+158\text{ }^\circ\text{F}$ | | | -20 to $+80\text{ }^\circ\text{C}$ -4 to $+176\text{ }^\circ\text{F}$ (Pressure port: -20 to $+125\text{ }^\circ\text{C}$ -4 to $+257\text{ }^\circ\text{F}$, No dew condensation or icing allowed), Storage: -30 to $+100\text{ }^\circ\text{C}$ -22 to $+212\text{ }^\circ\text{F}$ [e-CON connector (accessory): -20 to $+75\text{ }^\circ\text{C}$ -4 to $+167\text{ }^\circ\text{F}$ (Storage: -30 to $+75\text{ }^\circ\text{C}$ -22 to $+167\text{ }^\circ\text{F}$)] | |
| | Ambient humidity | 35 to 85 % RH, Storage: 35 to 85 % RH | | | | |
| | Medium temperature range | -20 to $+70\text{ }^\circ\text{C}$ -4 to $+158\text{ }^\circ\text{F}$ | | | -20 to $+125\text{ }^\circ\text{C}$ -4 to $+257\text{ }^\circ\text{F}$ | |
| | Voltage withstandability | 150 V AC for one min. between all supply terminals connected together and enclosure | | | | |
| | Insulation resistance | 100 M Ω , or more, with 50 V DC megger between all supply terminals connected together and enclosure | | | | |
| | Vibration resistance | 10 to 2,000 Hz frequency, acceleration 200 m/s ² , in X direction for four hours, in Y and Z directions for two hours each (Note 5) | | | | |
| | Shock resistance | 1,000 m/s ² acceleration in X, Y and Z directions three times each | | | | |
| Grounding method | | Capacitor earth (Enclosure-supply terminal) | | | | |
| Pressure port | | R1/4 male thread (throttle embedded) | | | | |
| Material | | Diaphragm: Stainless steel (SUS630), Pressure port: Stainless steel (SUS304), Throttle: Stainless steel (SUSXM7) | | | | |
| Connecting method | | Connector | | | | |
| Cable | | 0.2 mm ² 3-core heat resistant cabtyre cable 2 m 3.562 ft long | | | | |
| Cable extension | | Extension up to total 10 m 32.808 ft is possible with 0.2 mm ² , or more, cable. | | | | |
| Weight | | Net weight: 100 g approx., Gross weight: 150 g approx. | | | | |
| Accessory | | Connector (e-CON): 1 pc. | | | | |

- Notes: 1) Where measurement conditions have not been specified precisely, the conditions used were an ambient temperature of $+23\text{ }^\circ\text{C}$ $+73.4\text{ }^\circ\text{F}$.
 2) The sensor head can be used independently.
 3) Oil is used in the factory inspection process for models **DPH-L114** and **DPH-L154**. There may be some residual oil inside the pressure port.
 4) The sensor's internal mechanism is sealed based on an air pressure of 1,013 hPa.
 5) The X, Y, and Z directions are defined as follows:

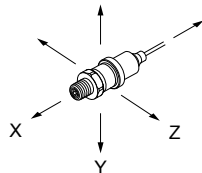

SPECIFICATIONS

Controllers

| Item | Model No. | NPN output | DPC-L101 | | | |
|--|---|--|--|--|--|---|
| | | PNP output | DPC-L101-P | | | |
| CE marking directive compliance | | EMC Directive, RoHS Directive | | | | |
| Applicable sensor head | | DPH-L113V | DPH-L113 | DPH-L133 | DPH-L114 | DPH-L154 |
| Rated pressure range | | -0.1 to +1 MPa | 0 to +1 MPa | 0 to +3.5 MPa | 0 to +10 MPa | 0 to +50 MPa |
| Set pressure range | | -1.177 to +1.177 MPa { -12.00 to +12.00 kgf/cm ² -11.77 to +11.77 bar -170.6 to +170.6 psi } | -1.070 to +1.070 MPa { -10.91 to +10.91 kgf/cm ² -10.70 to +10.70 bar -155.2 to +155.2 psi } | -3.74 to +3.74 MPa { -38.1 to +38.1 kgf/cm ² -37.4 to +37.4 bar -542 to +542 psi } | -10.70 to +10.70 MPa { -109.1 to +109.1 kgf/cm ² -107.0 to +107.0 bar -1552 to +1552 psi } | -53.5 to +53.5 MPa { -545 to +545 kgf/cm ² -535 to +535 bar -1980 to +17760 psi } |
| Set resolution | | 0.001 MPa | 0.001 MPa | 0.01 MPa | 0.01 MPa | 0.1 MPa |
| Display | | 4 digits + 4 digits 3-color LCD display (Display refresh rate: 250 ms, 500 ms, 1,000 ms, selectable by key operation) | | | | |
| Displayable pressure range | | -0.155 to +1.022 MPa { -1.58 to +10.42 kgf/cm ² -1.55 to +10.22 bar -22.4 to +148.2 psi } | -0.050 to +1.020 MPa { -0.51 to +10.40 kgf/cm ² -0.50 to +10.20 bar -7.2 to +148.0 psi } | -0.17 to +3.57 MPa { -1.7 to +36.4 kgf/cm ² -1.7 to +35.7 bar -24 to +518 psi } | -0.50 to +10.20 MPa { -5.1 to +104.0 kgf/cm ² -5.0 to +102.0 bar -72 to +1480 psi } | -2.5 to +51.0 MPa { -25 to +520 kgf/cm ² -25 to +510 bar -360 to +7400 psi } |
| Supply voltage | | 12 to 24 V DC $\pm 10\%$ Ripple P-P 10 % or less | | | | |
| Power consumption | | Normal operation: 960 mW or less (Current consumption 40 mA or less at 24 V supply voltage) ECO mode (STD): 720 mW or less (Current consumption 30 mA or less at 24 V supply voltage) ECO mode (FULL): 600 mW or less (Current consumption 25 mA or less at 24 V supply voltage) Excluding the current consumption of sensor head and analog output current | | | | |
| Comparative outputs (Comparative output 1, 2) | | <NPN output type> NPN open-collector transistor (2 outputs) • Maximum sink current: 50 mA • Applied voltage: 30 V DC or less (between comparative output and 0 V) • Residual voltage: 1 V or less (at 50 mA sink current) | | <PNP output type> PNP open-collector transistor (2 outputs) • Maximum source current: 50 mA • Applied voltage: 30 V DC or less (between comparative output and +V) • Residual voltage: 1 V or less (at 50 mA source current) | | |
| Output operation | | NO/NC, selectable by key operation | | | | |
| Output modes | | EASY mode / Hysteresis mode / Window comparator mode | | | | |
| Hysteresis | | Minimum 1 digit (variable) (however, 2 digits when using psi unit) | | | | |
| Repeatability | | Within $\pm 0.2\%$ F.S. | | | | |
| Response time | | 5 ms, 10 ms, 25 ms, 50 ms, 100 ms, 250 ms, 500 ms, 1,000 ms, 5,000 ms, selectable by key operation | | | | |
| Short-circuit protection | | Incorporated | | | | |
| Analog output | | <Analog voltage output> • Output current: 1 to 5 V DC • Zero point: within 1 V $\pm 0.5\%$ F.S. (excluding DPH-L113V) within 1.364 V $\pm 0.5\%$ F.S. (DPH-L113V) • Span: within 4 V $\pm 0.5\%$ F.S. • Linearity: within $\pm 0.1\%$ F.S. • Output impedance: 1 k Ω approx. | | <Analog current output> • Output current: 4 to 20 mA • Zero point: within 4 mA $\pm 1.0\%$ F.S. (excluding DPH-L113V) within 5.455 mA $\pm 1.0\%$ F.S. (DPH-L113V) • Span: within 16 mA $\pm 1.5\%$ F.S. • Linearity: within $\pm 0.1\%$ F.S. • Load resistance: 250 Ω (max.) | | |
| Inputs | Sensor head input | Input voltage range: 1 to 5 V DC (over rated pressure range) | | | | |
| | External input | <NPN output type> ON voltage: 0.4 V DC or less OFF voltage: 5 to 30 V DC, or open Input impedance: 10 k Ω approx. Input time: 1 ms or more | | <PNP output type> ON voltage: 5 V to +V DC OFF voltage: 0.6 V DC or less, or open Input impedance: 10 k Ω approx. Input time: 1 ms or more | | |
| Operation indicator | | Orange LED (Comparative output 1 operation indicator, comparative output 2 operation indicator: Lights up when each comparative output is ON) | | | | |
| Environmental resistance | Protection | IP40 (IEC) | | | | |
| | Ambient temperature | -10 to +50 °C +14 to +122 °F (No dew condensation or icing allowed), Storage: -10 to +60 °C +14 to +140 °F | | | | |
| | Ambient humidity | 35 to 85 % RH, Storage: 35 to 85 % RH | | | | |
| | Voltage withstandability | 500 V AC for one min. between all supply terminals connected together and enclosure | | | | |
| | Insulation resistance | 50 M Ω , or more, with 500 V DC megger between all supply terminals connected together and enclosure | | | | |
| | Vibration resistance | 10 to 500 Hz frequency, double amplitude 3 mm 0.118 in or maximum acceleration 196 m/s ² , in X, Y and Z directions for two hours each (when panel mounting bracket is mounted: 10 to 150 Hz frequency, double amplitude 0.75 mm 0.030 in or maximum acceleration 49 m/s ² , in X, Y and Z directions for two hours each) | | | | |
| Shock resistance | 100 m/s ² acceleration in X, Y and Z directions three times each | | | | | |
| Temperature characteristics | | Within $\pm 0.5\%$ F.S. (ambient temperature range based on +20 °C +68 °F) | | | | |
| Material | | Enclosure: PBT (glass fiber reinforced), LCD display: Acrylic, Mounting threaded part: Brass (nickel plated), Switch part: Silicone rubber | | | | |
| Connecting method | | Connector | | | | |
| Cable length | | Total length up to 100 m 328.084 ft (less than 30 m 98.425 ft when conforming to CE marking) is possible with 0.3 mm ² , or more, cable. | | | | |
| Weight | | Net weight: 25 g approx. (excluding connector attached cable), Gross weight: 140 g approx. | | | | |
| Accessories | | CN-66A-C2 (Connector attached cable 2 m 6.562 ft), Pressure unit label: 1 set | | | | |

Notes: 1) Where measurement conditions have not been specified precisely, the conditions used were an ambient temperature of +20 °C +68 °F.
2) The values specified above are applied only to the controller.

I/O CIRCUIT AND WIRING DIAGRAMS

DPC-L101

NPN output type

I/O circuit diagram

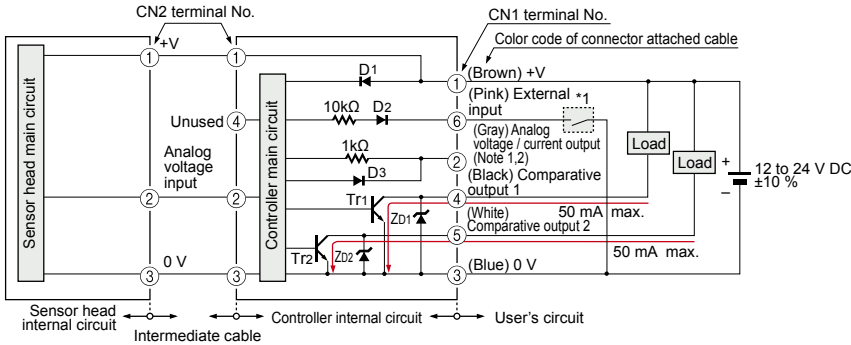

- Notes: 1) Set the output load resistance during analog current output to 250 Ω (max.).
- 2) Note that a voltage of 5 V or higher is generated during analog current output.

Symbols ... D₁ to D₃: Reverse supply polarity protection diode
 ZD₁, ZD₂: Surge absorption zener diode
 Tr₁, Tr₂: NPN output transistor

*1

Non-voltage contact or NPN open-collector transistor

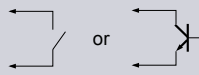

High (5 to 30 V DC, or open): Invalid
 Low (0.4 V DC or less): Valid

For independent use of sensor head

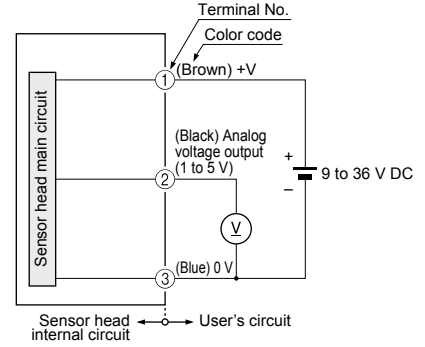

- Notes: 1) When the sensor head is used independently, devices connected to the analog output must have an input impedance set at 10 kΩ or more and load capacity 1,000 pF or less.
- 2) No short-circuit protection circuit is provided for analog voltage output. Do not connect directly to a power supply.
- 3) The pressure port and internal circuitry are connected by a capacitor. Do not apply voltage in excess of the specifications' dielectric strength between the pressure port and wiring.
- 4) The transparent tube attached to the cable is not used and should be cut off at the base.

DPC-L101-P

PNP output type

I/O circuit diagram

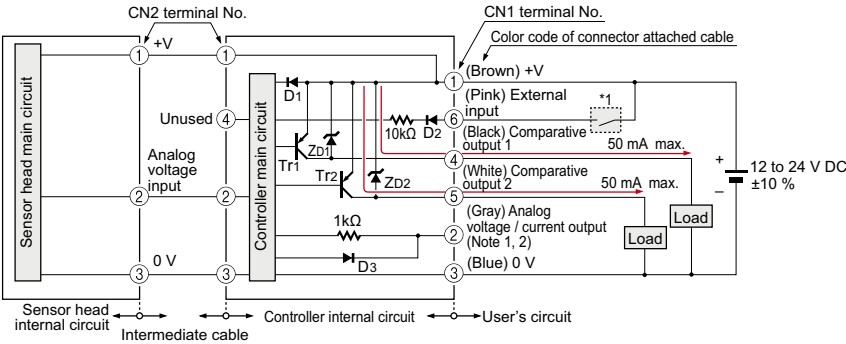

- Notes: 1) Set the output load resistance during analog current output to 250 Ω (max.).
- 2) Note that a voltage of 5 V or higher is generated during analog current output.

Symbols ... D₁ to D₃: Reverse supply polarity protection diode
 ZD₁, ZD₂: Surge absorption zener diode
 Tr₁, Tr₂: PNP output transistor

*1

Non-voltage contact or PNP open-collector transistor

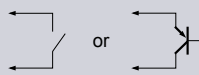

High (5 to +V DC, or open): Invalid
 Low (0.6 V DC or less, or open): Valid

For independent use of sensor head

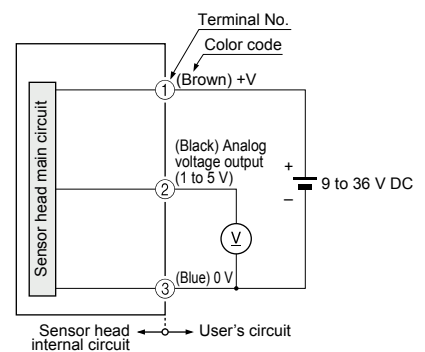

- Notes: 1) When the sensor head is used independently, devices connected to the analog output must have an input impedance set at 10 kΩ or more and load capacity 1,000 pF or less.
- 2) No short-circuit protection circuit is provided for analog voltage output. Do not connect directly to a power supply.
- 3) The pressure port and internal circuitry are connected by a capacitor. Do not apply voltage in excess of the specifications' dielectric strength between the pressure port and wiring.
- 4) The transparent tube attached to the cable is not used and should be cut off at the base.

I/O CIRCUIT AND WIRING DIAGRAMS

Terminal arrangement diagram

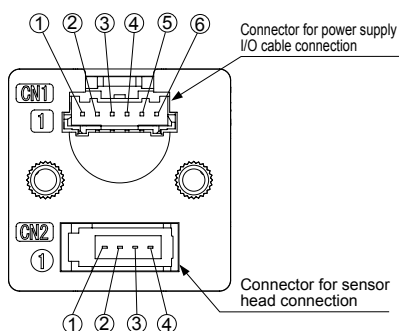

Connector for power supply I/O cable (CN1)

- ① +V
- ② Analog voltage / current output
- ③ 0 V
- ④ Comparative output 1
- ⑤ Comparative output 2
- ⑥ External input
(auto-reference function / remote zero-adjustment function / current value hold function)

Connector for sensor head (CN2)

- ① Sensor head supply voltage
- ② Analog voltage input
- ③ 0 V
- ④ Unused

PRECAUTIONS FOR PROPER USE



- Never use this product as a sensing device for personnel protection.
- In case of using sensing devices for personnel protection, use products which meet laws and standards, such as OSHA, ANSI or IEC etc., for personnel protection applicable in each region or country.
- The **DPH-L100** series is designed for use with air and non-corrosive gas. It cannot be used with liquid or corrosive and inflammable gases.

Others

- Never remove the throttle.
- Use within the rated pressure range.
- Do not apply pressure exceeding the pressure withstandability value. The diaphragm will get damaged and correct operation shall not be maintained.
- Do not use during the initial transient time (controller: 0.5 sec. approx, sensor head: 50 ms approx.) after the power supply is switched on.
- Avoid dust, dirt, and steam.
- Take care that the sensor does not come in direct contact with water, oil, grease, or organic solvents, such as, thinner, etc.
- Do not insert wires, etc., into the pressure port. The diaphragm will get damaged and correct operation shall not be maintained.
- Do not operate the keys with pointed or sharp objects.

Part description

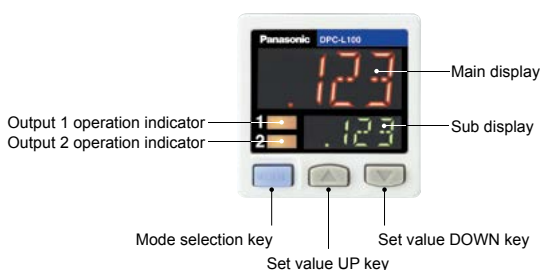

Wiring

- Make sure that the power supply is off while wiring.
- Verify that the supply voltage variation is within the rating.
- If power is supplied from a commercial switching regulator, ensure that the frame ground (F.G.) terminal of the power supply is connected to an actual ground.
- In case noise generating equipment (switching regulator, inverter motor, etc.) is used in the vicinity of this sensor, connect the frame ground (F.G.) terminal of the equipment to an actual ground.
- Do not run the wires together with high-voltage lines or power lines or put them in the same raceway. This can cause malfunction due to induction.
- Incorrect wiring will cause problems with operation.

DIMENSIONS (Unit: mm in)

The CAD data can be downloaded from our website.

MS-DP1-2 MS-DP1-3

Panel mounting bracket (Optional), Front protection cover (Optional)

Assembly dimensions

Mounting drawing with **DPC-L101(-P)**

Vertical mounting

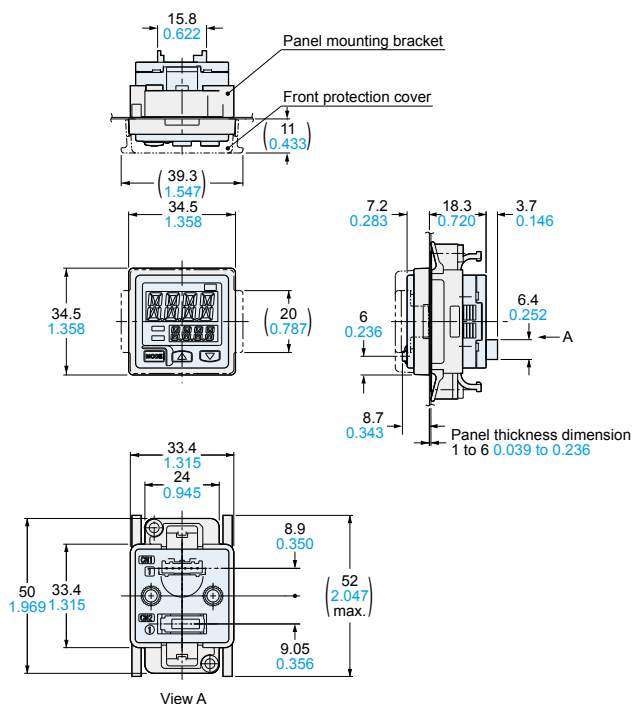

Horizontal mounting

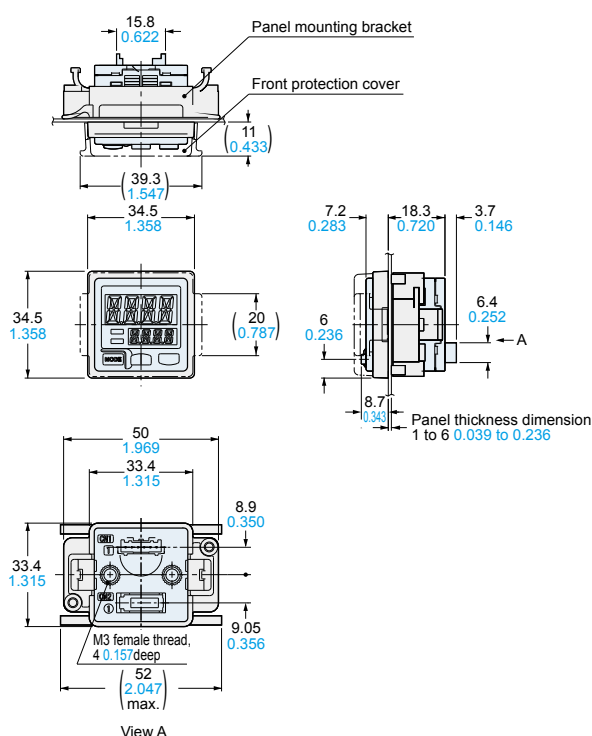

Material: Polyacetal (Panel mounting bracket)
Polycarbonate (Front protection cover)

Panel cut-out dimensions

When 1 unit is installed

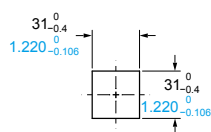

When "n" units are installed horizontally in series

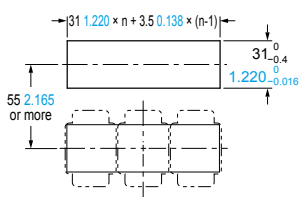

Note: The panel thickness should be 1 to 6 mm 0.039 to 0.236 in.

When "n" units are installed vertically in series

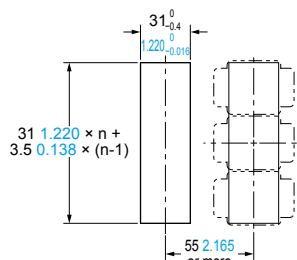

Note: The panel thickness should be 1 to 6 mm 0.039 to 0.236 in.

CN-66A-C2 CN-66A-C5

Connector attached cable (Optional, **CN-66A-C2** is attached to the controller)

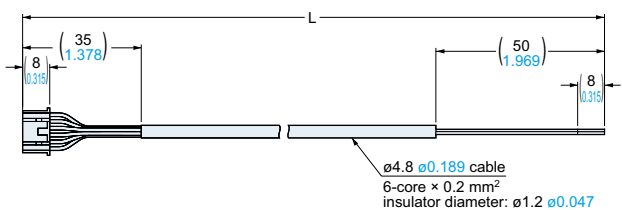

• Length L

| Model No. | Length L |
|------------------|---------------|
| CN-66A-C2 | 2,000 78.740 |
| CN-66A-C5 | 5,000 196.850 |

Disclaimer

The applications described in the catalog are all intended for examples only. The purchase of our products described in the catalog shall not be regarded as granting of a license to use our products in the described applications. We do NOT warrant that we have obtained some intellectual properties, such as patent rights, with respect to such applications, or that the described applications may not infringe any intellectual property rights, such as patent rights, of a third party.

Panasonic
INDUSTRY

Panasonic Industry Co., Ltd.

Industrial Device Business Division
7-1-1, Morofuku, Daito-shi, Osaka 574-0044, Japan
industrial.panasonic.com/ac/e/