

FK-23451-000

SHT 1.1

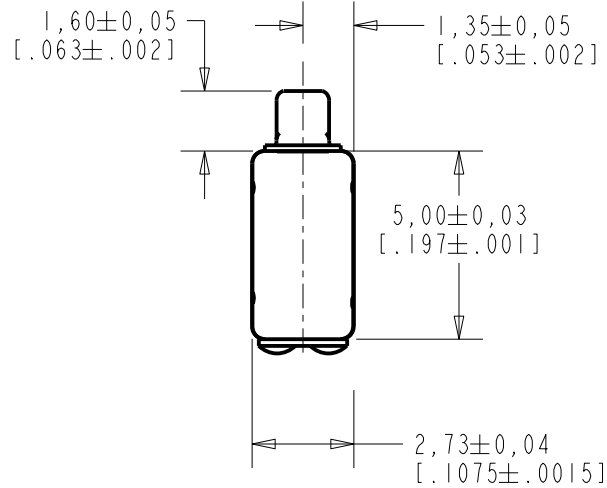

NOTES:

- 1 A POSITIVE GOING VOLTAGE AT TERMINAL 2, RELATIVE TO TERMINAL 1, CAUSES A DECREASE IN PRESSURE AT THE SOUND OUTLET.
- 2 LOCATED FROM TWO SURFACES FOR CUSTOMER CONVENIENCE. ONLY APPLICABLE FROM ONE SURFACE, NOT TO BE USED TOGETHER.

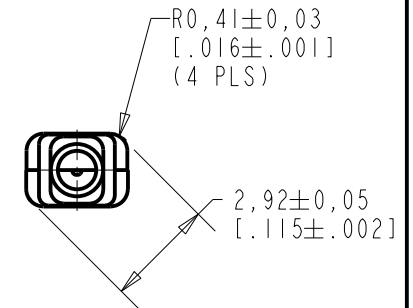
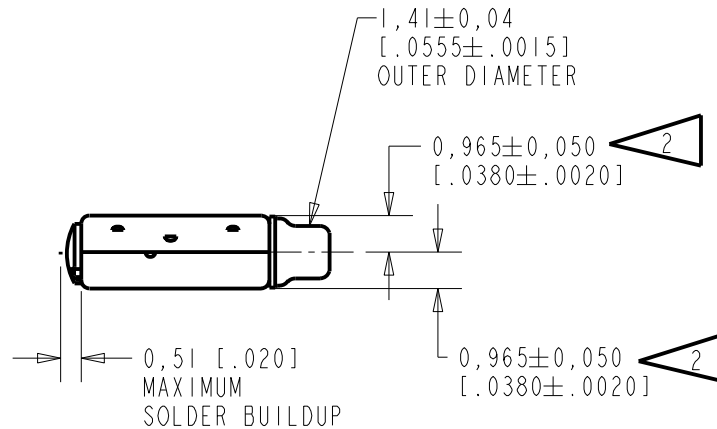
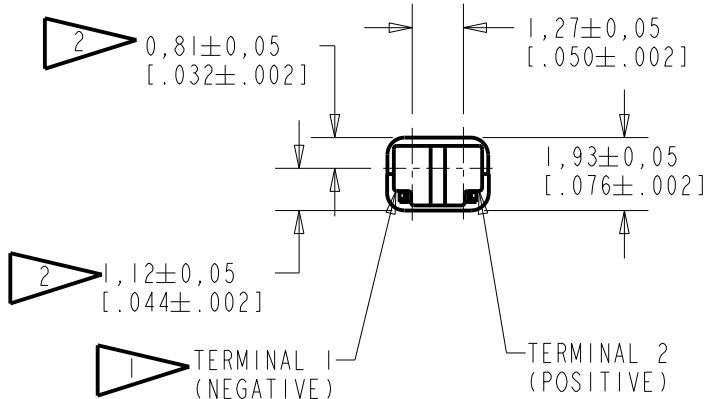

SCALE 2:1
NOMINAL WEIGHT
.11 GRAMS

DIMENSIONS IN MILLIMETERS [INCHES]

KNOWLES ELECTRONICS
ITASCA, ILLINOIS U.S.A.

Revision	C.O. #	Implementation Date	RELEASE LEVEL	REVISION
			Active	D
D	C10114032	11-7-12		

SCALE: 5:1		DR. BY DATE
DO NOT SCALE DRAWING		MMM 9-6-05
TITLE: RECEIVER		FK-23451-000
OUTLINE DRAWING		SHT 1.1
		CK. BY DATE
		GJP 9-12-05
		APP. BY DATE
		GJP 9-12-05

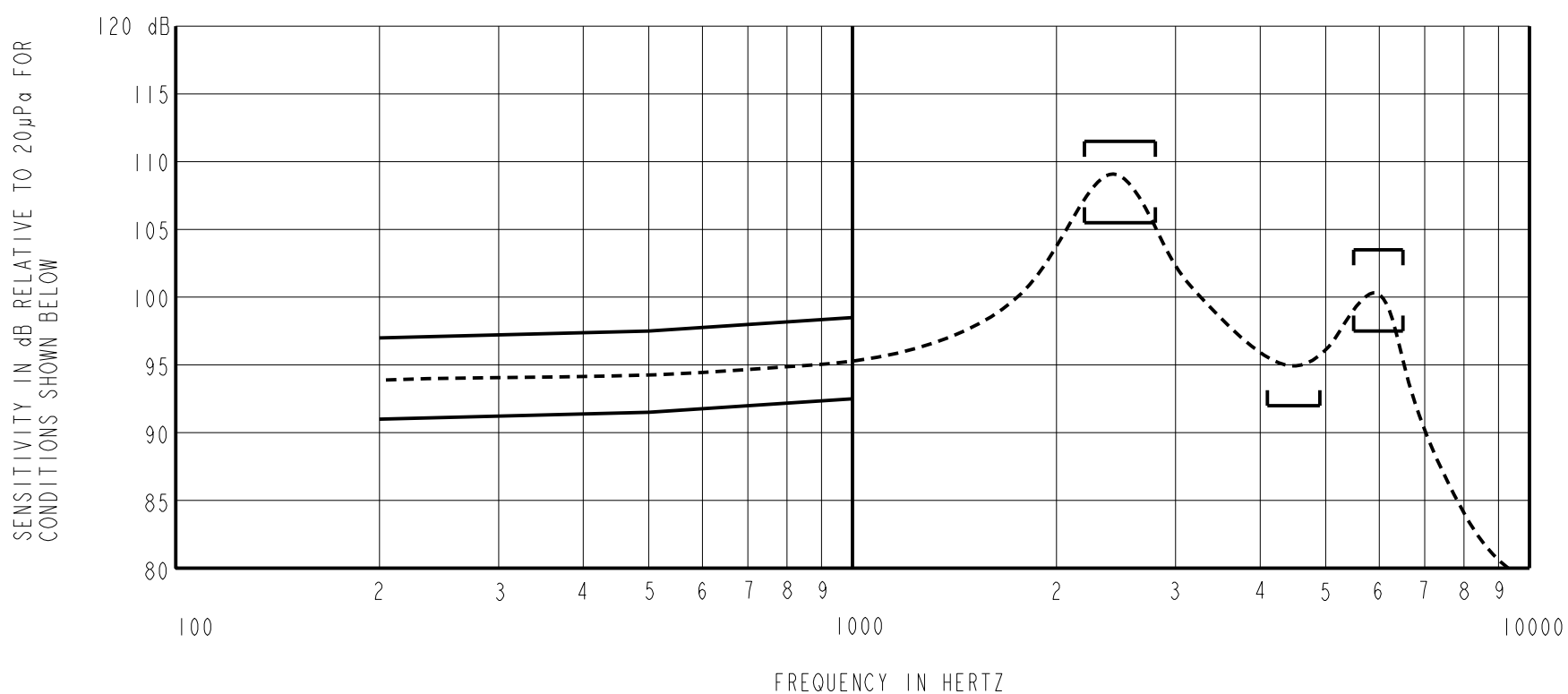

ACOUSTICAL

SENSITIVITY
DEVICE PRODUCE THE SPL LISTED BELOW UNDER TEST CONDITIONS IN TABLE 3.
NOMINAL SENSITIVITY AT 1kHz IS dB RELATIVE TO 20 µPa.

FREQUENCY (Hz)	MINIMUM	NOMINAL	MAXIMUM
200	91.0	94.0	97.0
500	91.5	94.5	97.5
1000	92.5	95.5	98.5
2200-2800	105.5	110.5	115.5
4100-4900	92.0	---	---
5500-6500	97.5	100.5	103.5

PORT LOCATION: 12S

TABLE 1

TOTAL HARMONIC DISTORTION
DEVICE WILL NOT EXCEED TOTAL HARMONIC DISTORTION LEVELS LISTED BELOW.

FREQUENCY (Hz)	AC DRIVE (mA rms)	DC BIAS (mA)	LIMIT (%)
800	0.5	0	5
2400	1.0	0	10

TABLE 2

TEST CONDITIONS

NOMINAL SOURCE VOLTAGE	0.5 mA rms, 0 mA DC BIAS
SOURCE IMPEDANCE	<1 Ohm
TUBING	10mm [.394"] LONG, 1mm [.039"] I.D.
COUPLER CAVITY	2 CM ³ , SIMULATED ANSI S3.7 TYPE HA-3 (IEC 60318-5)

TABLE 3

ELECTRICAL

DC RESISTANCE	360 Ohms ± 10%
IMPEDANCE @ 500 Hz	450 Ohms ± 15%
IMPEDANCE @ 1kHz	630 Ohms ± 15%

TABLE 4

ISOLATION: CASE WILL BE ELECTRICALLY ISOLATED FROM THE COIL CIRCUIT.

Revision	C.O. #	Implementation Date	RELEASE LEVEL	REVISION
			Active	D
D	C10114032	11-7-12		
WHEN TEST LIMITS ARE USED TO ESTABLISH INCOMING INSPECTION ACCEPTANCE/REJECTION CRITERIA, CORRELATION OF TEST EQUIPMENT WITH KNOWLES IS ALSO REQUIRED FOR ELIMINATION OF EQUIPMENT AND TEST METHOD VARIATION				
TITLE:		RECEIVER	FK-23451-000	DR. BY DATE MMM 9-6-05
		PERFORMANCE SPECIFICATION	SHT 2.1	CK. BY DATE GJP 9-12-05
				APP. BY DATE GJP 9-12-05

KNOWLES ELECTRONICS
ITASCA, ILLINOIS U.S.A.