

Nuvoton WAU8812/14-EVB Evaluation Board User's Guide

Rev: B

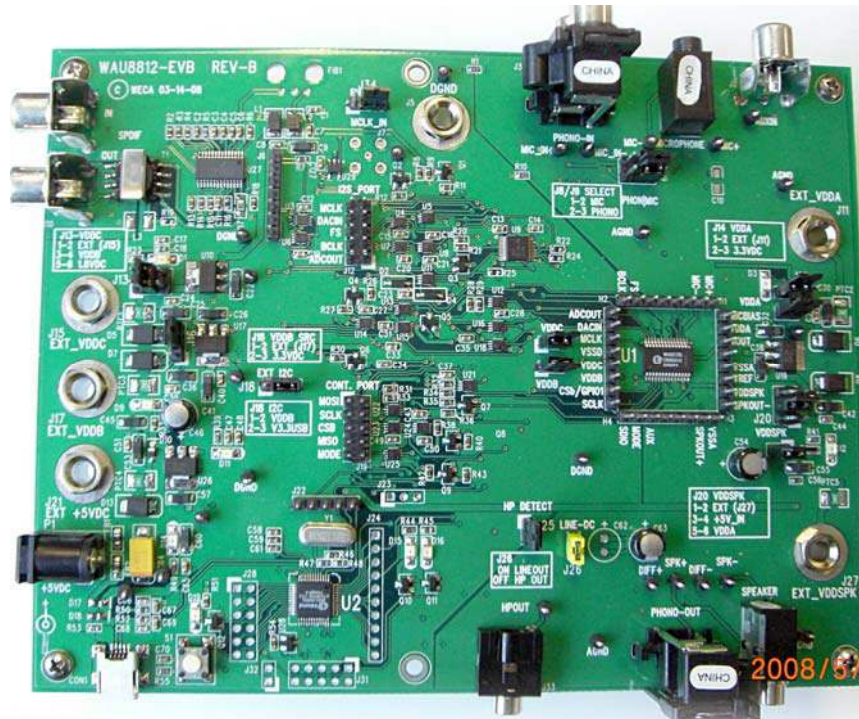

Table of Contents

Kit Content:	3
Hardware Description:	3
Jumpers and Connectors:	3
POWER:	3
Digital Input:	4
Digital Output:	5
ANALOG INPUT	5
ANALOG OUTPUT	6
USB CONNECTIONS	7
Jumpers:	8
WAU8812 Application Software:	9
Quick Set-Up:	9
Demo Panel:	10
Path view Panel:	11
Device Control Panel:	13
Input Signal path:	14
ADC/Filtering Panel:	15
Input Limiter and ALC Panel:	16
DAC Filtering/ Digital Audio Panel:	17
Output Path Panel:	18
Register Map Panel:	19
Script Panel:	20
WAU8812-EVB Board Schematics:	22
Block Diagram:	22
Analog outputs:	23
Level Translator:	24
Analog inputs:	25
W861308 USB controller:	26
SPDIF Interface:	27
Codec Power Supply:	27

Kit Content:

The WAU8812/14-EVB Board
 Application Software CD (WAU8812/14-EVP)
 User’s Guide (included in the supplied CD)

Hardware Description:

Evaluation board is controlled via USB cable. The on board Nuvoton W681308 USB Audio controller acts a SPI /I2C & I2S interface between the PC Software GUI and WAU8822 audio codec.

Jumpers and Connectors:

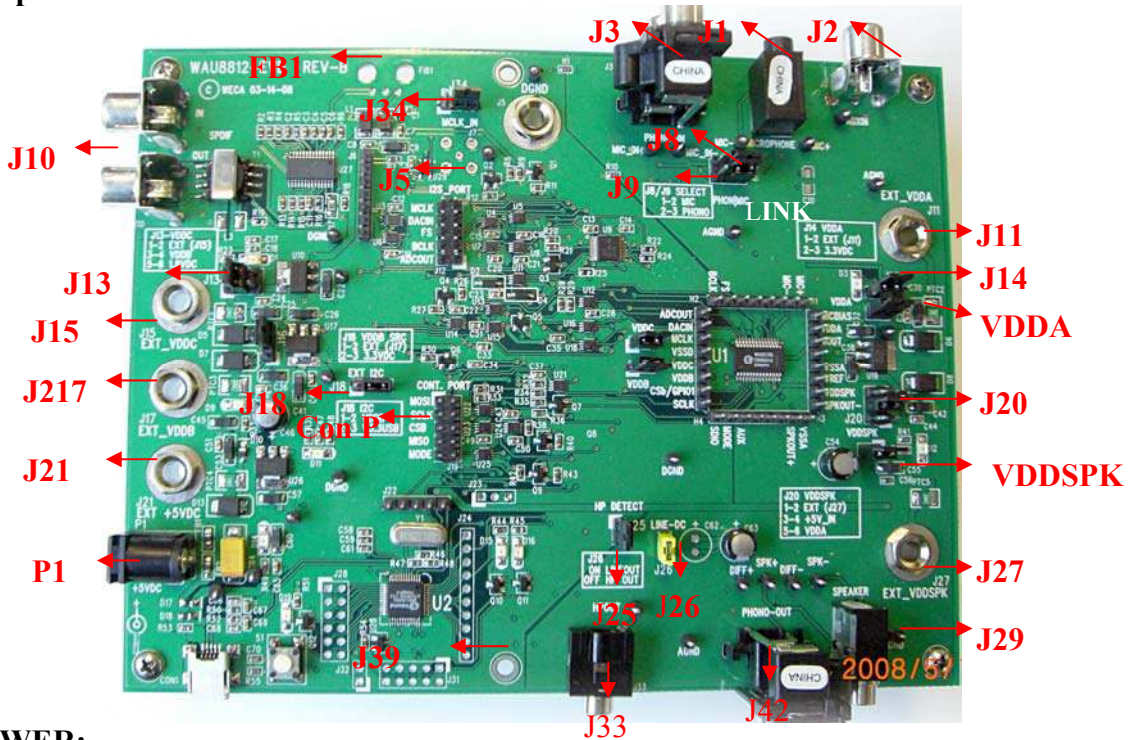

POWER:

Power is supplied to the WAU8812-EVB USB interface via the USB connector. If preferred it is also possible to supply +5V power to the level shifters using external supplies connected via Banana jacks.

- Using a USB cable +5V can be solely provided by the PC at CON1.
- If needed, a stronger 5V supply can be added using the 2.1mm jack at P1.
- Using Banana jacks the various supplies of the CODEC can also be supplied externally; connections are described below:

REF-DES	SOCKET NAME	SUPPLY
J26	EXT +5V IN	+5
J22	EXT VDDDB	1.8V to 3.6V
J18	EXT VDDC	1.6V to 3.6V
J6	DGND	0V
J19	EX VDDA	2.5V to 3.6V
J36	EX VDDSPK	2.5V to 5.0V

Digital Input:

There are three methods to input the required digital signal clocks to the WAU8812 audio interface.

- An AES/EBU, UEC958, S/PDIF, EIAJ CP340/1201 signal from coaxial input can be provided via a standard phono jack (J4),
- Direct digital input is available via a 1x7 pin header (J6)
- Digital Audio Interface is available via one side of a 2x10 pin header (J12)
 - This 3rd option supports an Audio Precision interface.

Level shifters have been included in the digital input interface path to provide signal buffering to the input signals; this allows an external clock source to be matched to the WAU8812 requirements.

The WAU8812 requires an MCLK input to produce an ADCOUT output, which can be derived either from S/PDIF signal clock recovery or by connecting an external MCLK direct to J6, TP26 or H2. The BCLK and FS clocks can also be derived from the S/PDIF signal clock recovery or by discrete input to header J6. **Please make a note that the on board USB controller is using 12Mhz as master clock. For accurate BCLK and FS use the WAU8812 PLL (Please program PLL and Clock generation registers accordingly or use the DAC/PLL/Digital Audio panel to set these register. See application software section)**

Reference Designator	Connector Style	Signal Name
J4	Phono Connector	SPDIF_IN
J6	SMB Connector	MCLK
J7	Header	MCLK_IN
J7 pin2	Header	SPDIF_ADCDAT_IN
J7 pin3	Header	SPDIF_FRAME_IN
J7 pin4	Header	SPDIF_BCLK_IN
J12 pin 1	Header	ADCOUT_AP
J12 pin 3	Header	BCLK_AP
J12 pin 5	Header	FS_AP
J12 pin 7	Header	DACIN_AP
J12 pin 9	Header	MCLK_AP

Digital Input Connections

Digital Output:

The ADC output can be obtained in the following ways:

- Converted to an S/PDIF signal via the CS8427CS device (U27) and output from the WAU8812-EVB evaluation board via a standard Phono connector (J10).
- The ADC output data and clocks may be accessed via a 1x7 pin header (J6).
- Digital Audio Interface is available via one side of a 2x10 pin header (J12)

Level shifters have been included in the digital input interface path to provide signal buffering to the output signals; this allows external receiver requirements to be met.

Reference Designator	Connector Style	Signal Name
J10	Phono Connector	SPDIF_OUT
J6	SMB Connector	MCLK
J7	Header	MCLK_IN
J7 pin2	Header	SPDIF_ADCDAT_IN
J7 pin3	Header	SPDIF_FRAME_IN
J7 pin4	Header	SPDIF_BCLK_IN
J12 pin 1	Header	ADCOUT_AP
J12 pin 3	Header	BCLK_AP
J12 pin 5	Header	FS_AP
J12 pin 7	Header	DACIN_AP
J12 pin 9	Header	MCLK_AP

ANALOG INPUT

The main analog inputs can be configured in one of two ways, either input via 4 phono connectors or via two jack sockets; both of which can be used with a pair of pseudo-differential input signals. Additional auxiliary inputs and line inputs can be input via two pairs of phono connectors. Jumpers J8 and J9 select between the jack socket or phono connector for each input.

Reference Designator	Connector Style	Signal Name
J8	Jack Socket	Left Mic Input
J9	Jack Socket	Right Mic Input
J1	Phono Connector	Mic Input
J2	Phono Connector	AUXIN
J3	Phono Connector	Phono Input

ANALOG OUTPUT

The analog outputs can be configured in one of two ways, either input via 4 phono connectors or via two jack sockets; both of which can be used with a pair of pseudo-differential input signals.

Reference Designator	Connector Style	Signal Name
J25	Header	HP-Detect
J29	Jack	SPK JACK (Mono)
J30	Phono Connector	SPK OUT P/N
J33	Jack Socket	Headphone

All WAU8812 pins are easily accessible via the headers running along each side of the device.

USB CONNECTIONS

The 2-wire or 3-wire control signals can be input from the control software via USB connector (CON1); these signals are interpreted by the Nuvoton W861308 USB Controller (U27). Alternatively it is possible to connect 2-wire or 3-wire control signals directly via J24.

Reference Designator	Connector Style	Pin Number	Signal Name
CON1	miniUSB Type B	1	VCC
		2	USBD-
		3	USBD+
		4	NC
		5	GND
		6	SHIELD
		7	SHIELD
		8	SHIELD
		9	SHIELD

Connector	Name	Description
J41	JTAG_ICE	JTAG ICE connector
J15	I2S_PORT	Direct interface Port for IS2 (digital audio)
J24	CONT_PORT	External Signal Interface (SPI)
J29	J29	For Internal use to program the W681308 USB controller
J37	J37	For Internal use to program the W681308 USB controller
J27	J27	For Internal use

Note that J15 and J24 can be used together to connect the Nuvoton WAU8812 Audio CODEC to any external controller.

Jumpers:

Jumpers	Default Position	Description
J8	1-2 (short)	Position 1-2 selects Right MIC and Position 2-3 selects Right Phono
J9	1-2 (short)	Position 1-2 selects Left MIC and Position 2-3 selects Left Phono
J13	3-4(short)	The 3 position jumper selects the VDDC source. Position 1-2 Selects External VDD, 3-4 Selects VDDB, and position 5-6 selects 1.8VDC
J14	2-3(short)	Selects the VDDA source, position 1-2 selects external source via J19 position 2-3 selects 3.3VDC
J16	2-3(short)	Selects the VDDDB source, position 1-2 selects external source via J22 position 2-3 selects 3.3VDC
J18	2-3(short)	Install for external I2C at VDDDB or I2C at 3.3V operation.
J20	3-4 (short)	Speaker VDD selection jumper. Position 1-2 selects external source via (J36), position 3-4 selects 5VDC and position 5-6 selects analog power (VDDA)
J23	2-3(short)	For Internal use with the W681308 USB controller
J25	1-2 (short)	Headphone detect
J26	1-2 (short)	Position 1-2 selects Headphone cap-less mode and
J34	2-3(short)	Install this jumper for external MCLK Position 1-2 enables external MCLK and position 2-3 disables the external MCLK.

Note: External clock to J8, TP33:

To use the WAU8812 as master you still need to apply an external clock to J7, TP33. Please disable any clock source from the board (Set J34 to position EN and in the application software, please select Slave I2S mode in device selection panel see page 13).

WAU8812 Application Software:



The WAU8812 Applications software is powerful and easy to use GUI software which enables the users to control the Nuvoton WAU8812 Mono Codec and aids system designers to develop software for their system's microcontroller.

- They are 4 ways to configure and control the W8812/!4 Audio Codec family with the WAU8812/14 Application Software.
 - **Demo Panel**
 - **Use predefined Saved Configurations**
 - **Click and configure**
 - **Script Panel**

Quick Set-Up:

- 1) Install the software from the CD, follow the on screen directions.
- 2) Connect the WAU8812-EVB to USB cable. Start the software, from the start up screen panel select device (WAU8812)
- 3) When the board is attached to the GUI via the USB cable the Green LED is lit (4)
- 4) Select the Demo Tab
- 5) Select Input/output paths
- 6) Load settings
- 7) Connect appropriate cables such as MIC, PHONO and Head-phones or speaker.

8) Evaluate the audio

To chose a different setting select another choice and load setting

Demo Panel:

In the demo panel there 2 easy steps for setting up and evaluating of a full working path

- **Step 1:** Choose Settings (selecting input such as MIC AUX or Line in - Output such as HP, SPKR or Line-out)
- **Step 2:** Load settings (writing to each individual control register). If you like to see the detailed description of the link click on (?) Next to each path to display full description of that path. Here once the desired path is set, you can evaluate the equalizer or ALC effects as well. In the WAU8814 device you will also see an equalizer display.

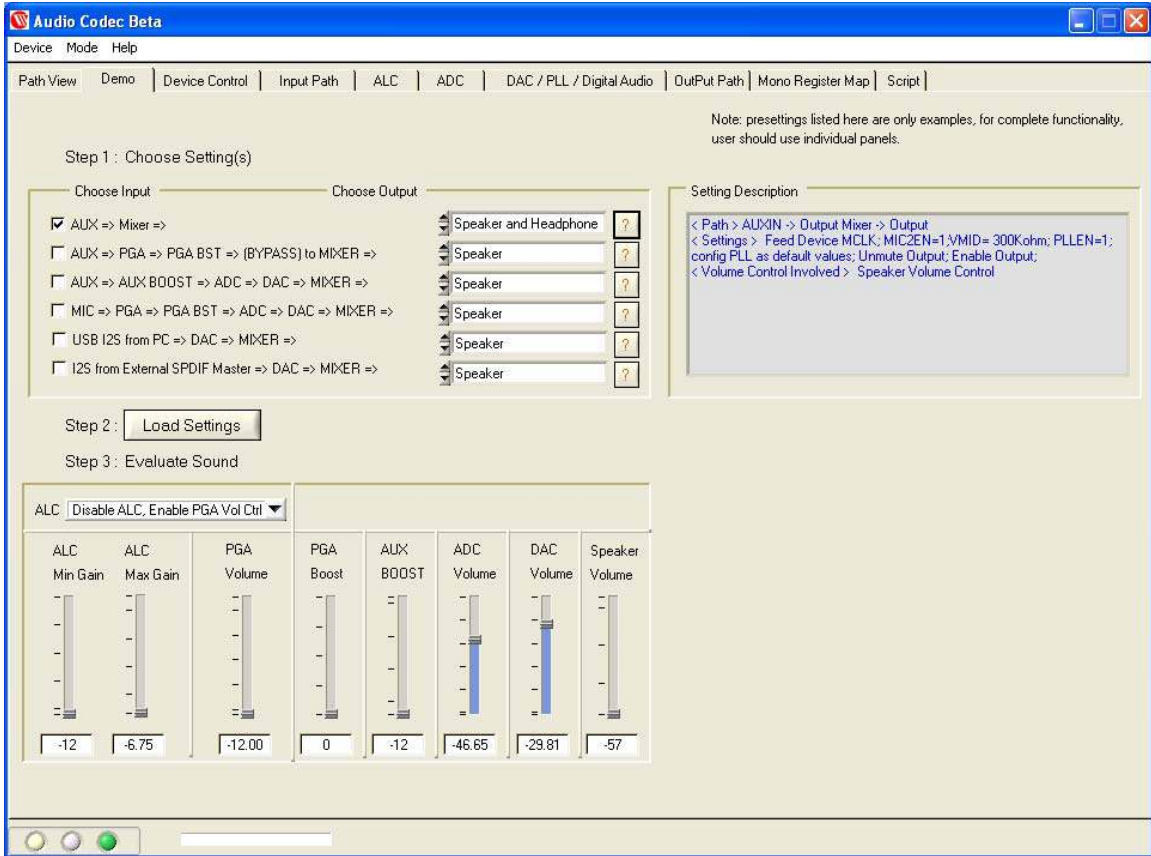

Saved Configurations:

In the Path view panel there are some examples of saved configuration. Double clicking on a saved configuration from the menu will activate that path. Selecting a saved configuration and update also activates that path. The Software automatically will write to each control register immediately. This useful feature can be used to tune different parameters and compare them later.

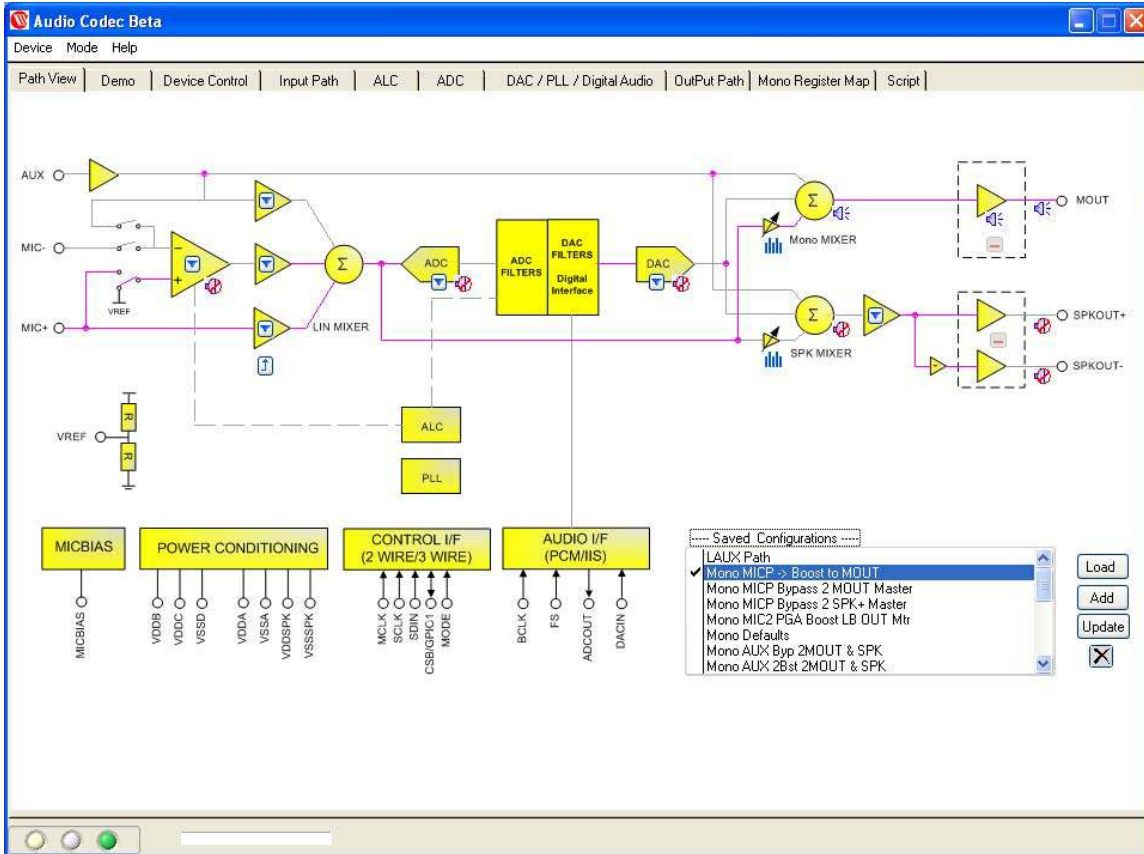

Path view Panel:

From the start up screen select WAU8812 to go to Mono GUI. The first screen you will see is a graphical representation of all relevant blocks of the WAU8812 Audio Codec called path view. Each block has its own screen panel witch represents associated control registers for that block. In this panel you can select various gains setting from the ring popup menus (1) or use Icons to mute and un-mute (2) (See Fig2).

The WAU8812 is configured through 56 registers. Each individual bit controls a function such as mute un-mute of input/output mixers and amplifiers.

In this panel you can set your desired input output path by clicking on the connecting lines. Notice each time a line is selected the active line is highlighted. The associated registers are written immediately so you can see and hear the immediate effect. Later you can save the path by clicking on add icon (3) for comparison with a different sets of parameters. To quickly get back to your original settings select Load.

The big blocks such as ALC, DAC, and EQ have more than one control bit. Clicking on specific block will take the users to its associated panel where you can set individual

control bits for that block. **Right click on that panel will take you back to the path view panel. Let's examine each individual panel**

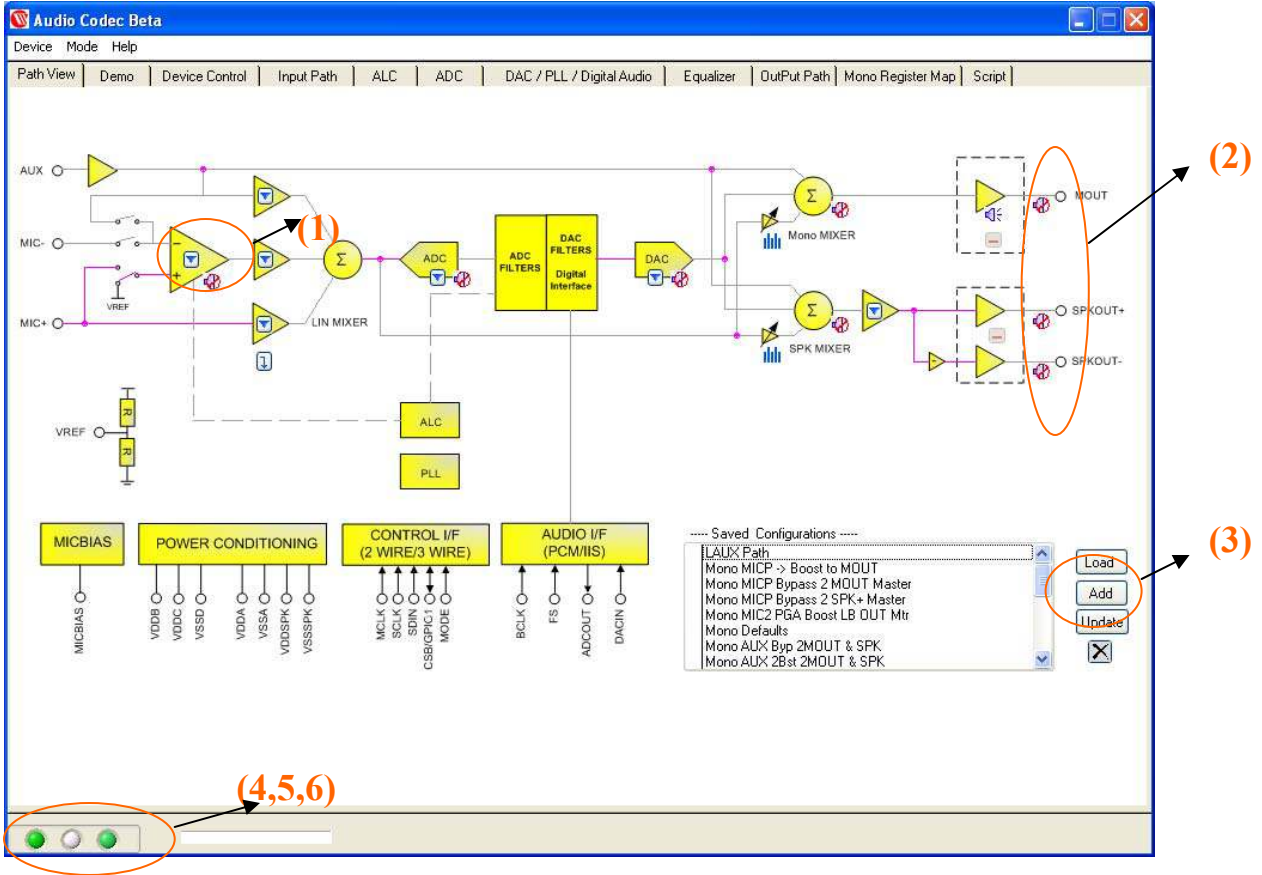

Fig2:
LED indicators.

In the left hand corner of the GUI there three indicators.

- 4) This indicator turns green when the WAU8812-EVB is attached to the USB cable.
- 5) This indicators turns green when the software loads setting for Demo panel.
- 6) This indictor turns green after when the software has finished writing to the WAU8812 register.

Device Control Panel:

SELECTION OF CONTROL MODE:

In this panel the user's selects device interfaces for WAU8812 from one of the following options:

- 3 Wire write only
- 4 Wire read and write
- I2C read and write
- External Control.

. The I2S signal connection section boxes configures the W8822-EVB to operate in I2S Master or Slave Mode. In the Master mode the MCLK is generated from:

- On board USB controller (select this option for playing Mono Audio from USB)
- Audio precision equipment
- Digital Audio (I2S) (Sect this is option for the SPDIF optical audio interface)

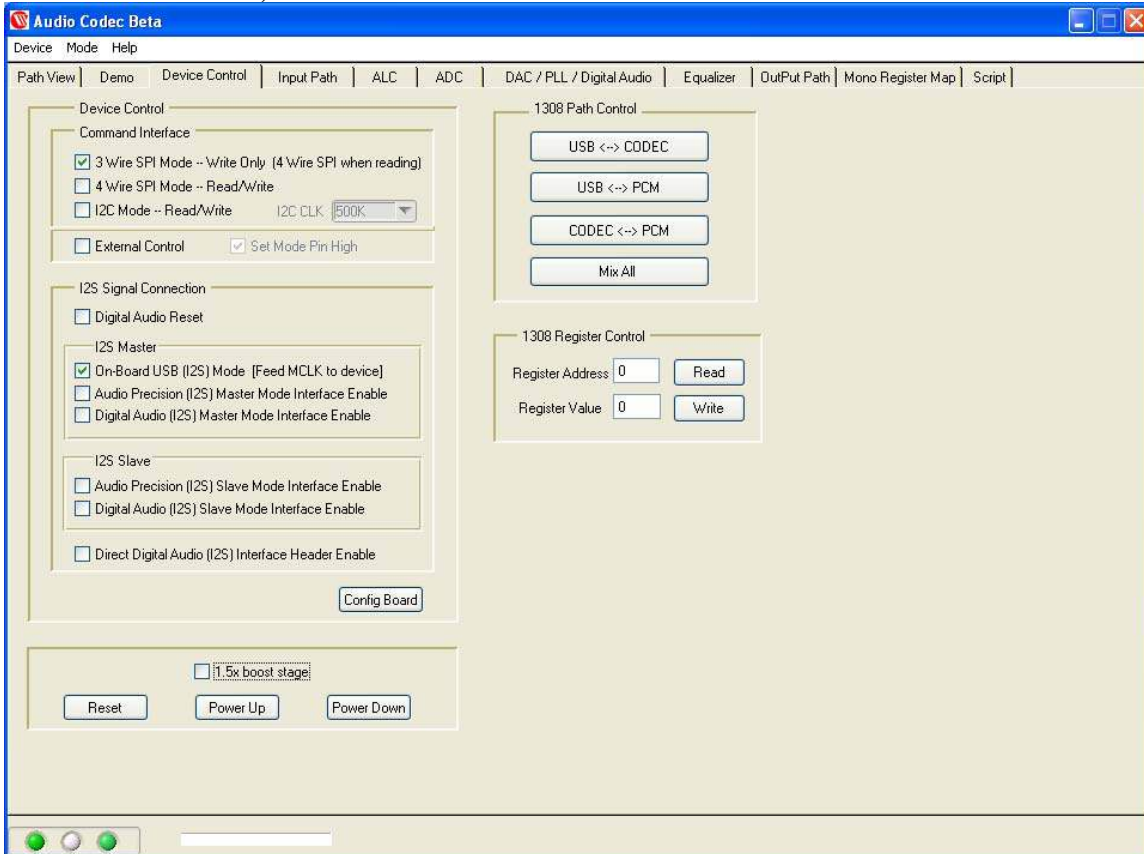

Once a device interface is selected, click on the Config Board button to configure the communication to the W8822-EVB board.

Note:

The default setting for WAU8812/14-EVB is not 1.5X boost stage. Please make sure to change J20 accordingly when using the Evaluation board in 3V mode.

Input Signal path:

In this panel power management and other control input bits are enabled/disabled. When a control bit is selected, the associated register is written automatically.

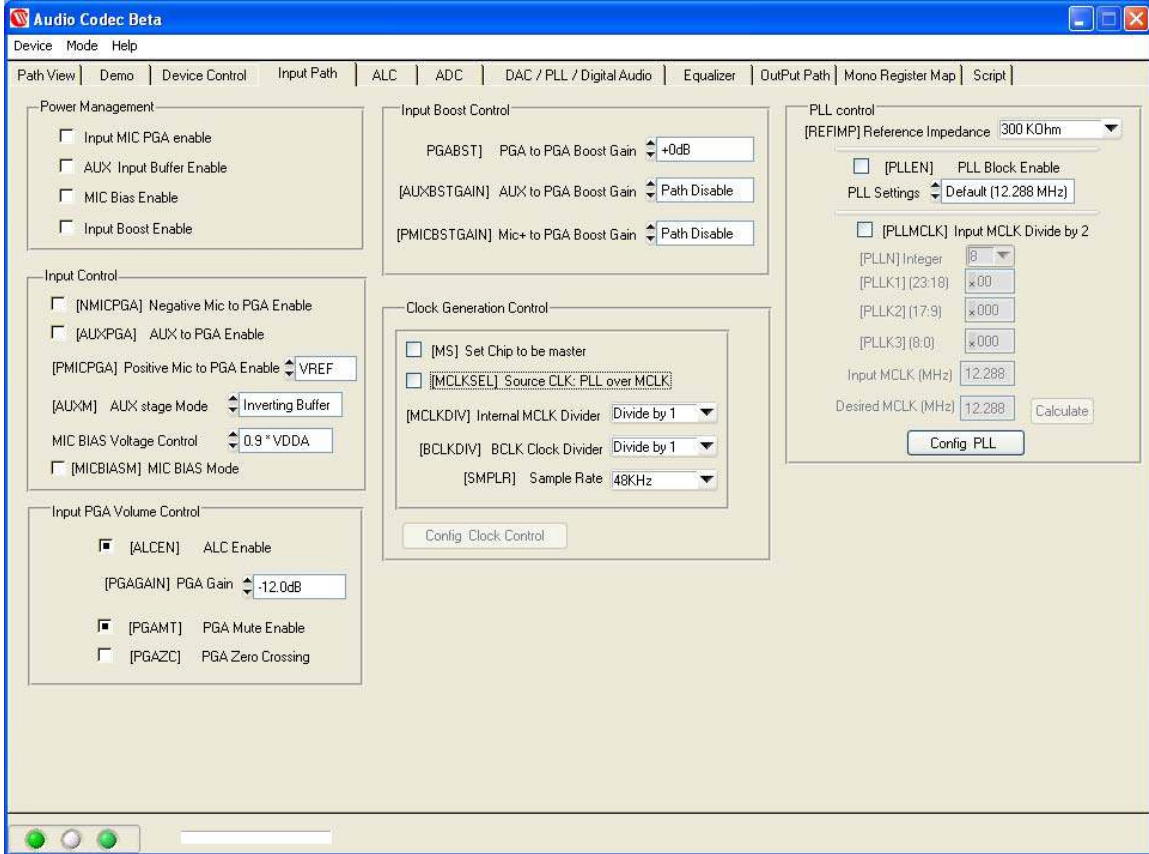

ADC/Filtering Panel:

The ADC control registers and notch filter is selected in this panel. In Digital ADC volume control section a pop up ring select window selects various gains. The selected values are written to its registers automatically.

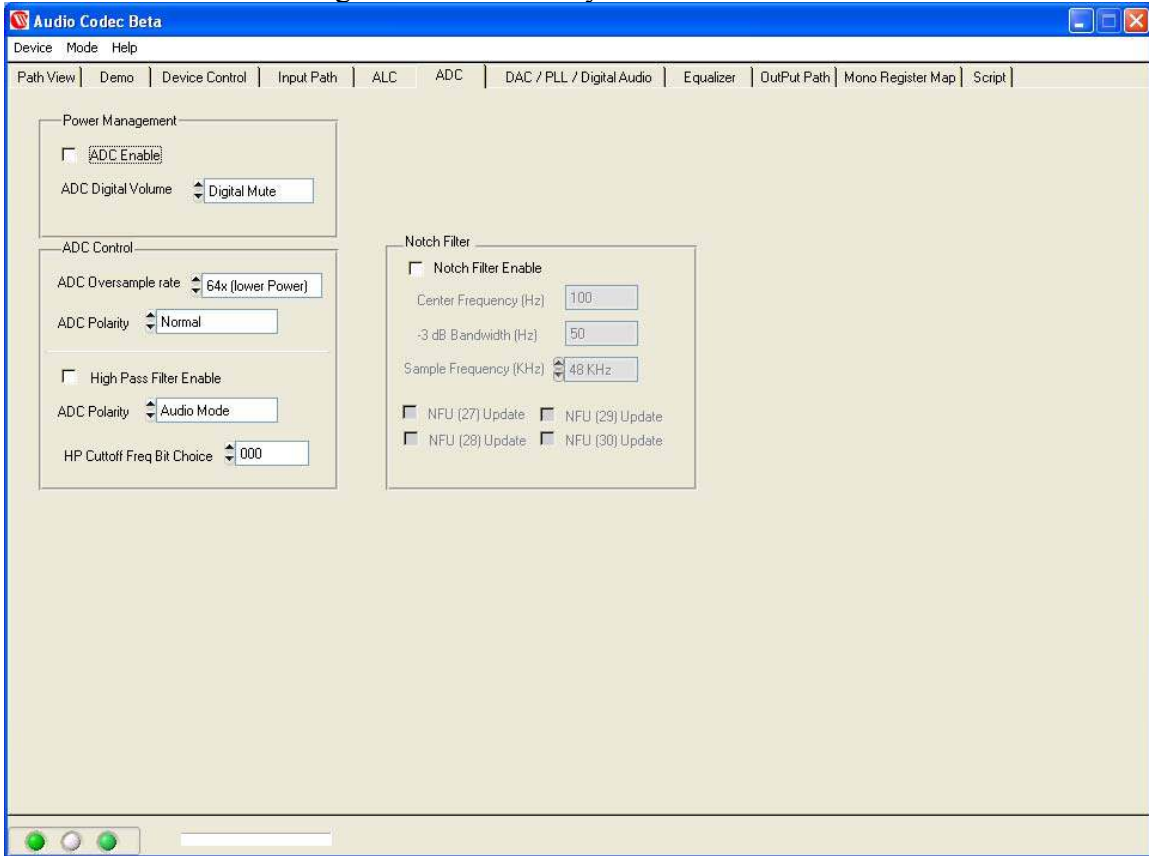

Input Limiter and ALC Panel:

In this panel aside from configuring the ALC stage to operate in normal or limiter modes, there is an ALC slider bar that sets the ALC control registers with pre defined parameters for Music, Speech and generic recording. These are suggested optimal values based on experiments and serves only as a guide for further optimization for the end portable application.

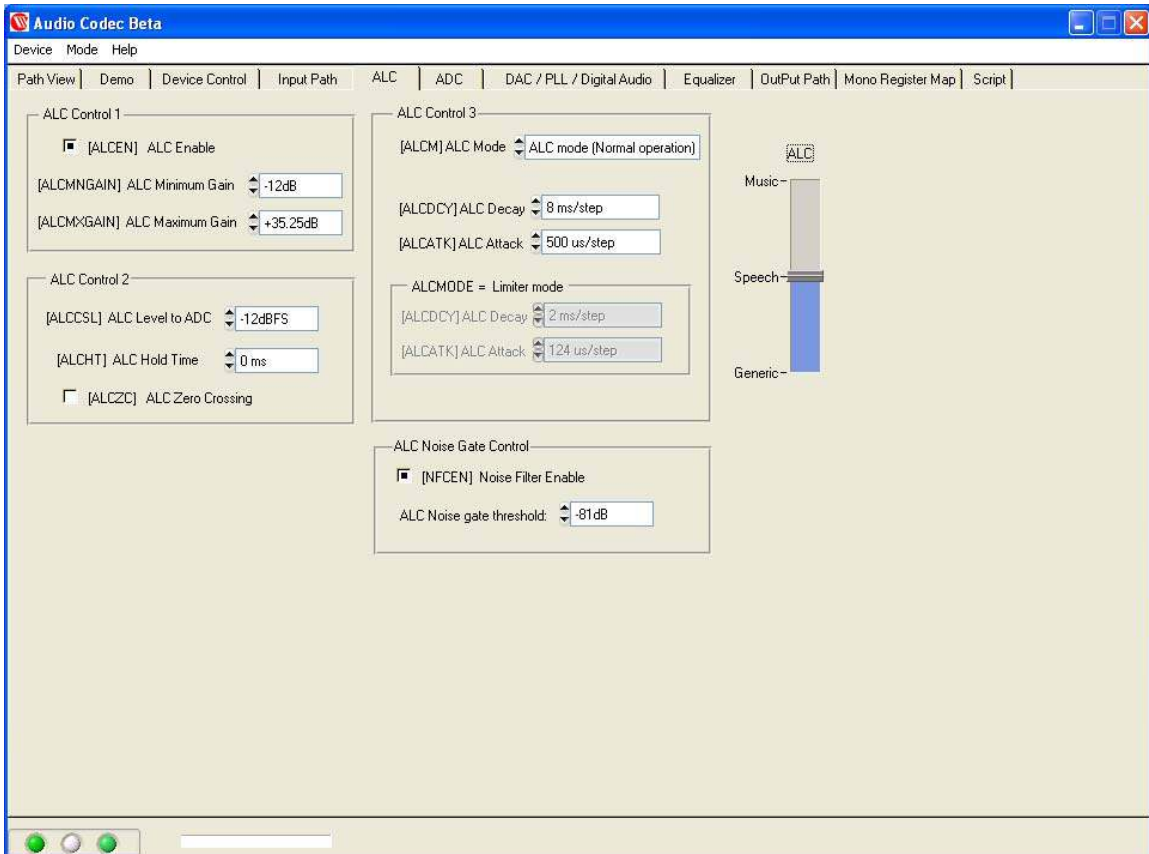

DAC Filtering/ Digital Audio Panel:

This Panel is divided into three sections;

- PLL
- DAC
- Digital Audio Control

In each section s control bit can be enabled or disabled. The associated registers are written automatically.

In the PLL sections the default is open circuit or disabled. There are two PLL setting (Default 12.2886 MHz) or custom setting, where valid supported frequencies are calculated given the PLL parameters. Other section in this panel enables or disables Clock Generation from external source, Companding control, Jack detect. The Audio Interface box also selects individual bits such FMT section and Word length.

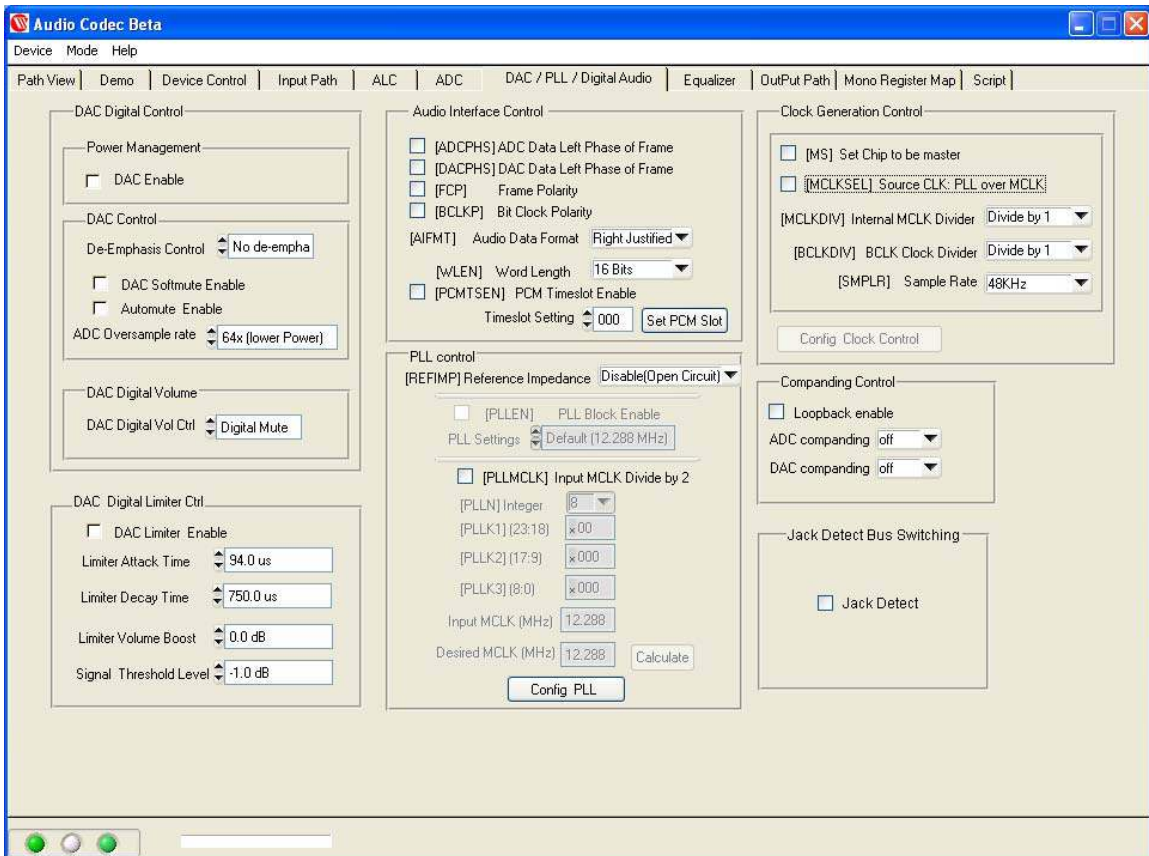

Output Path Panel:

In this panel all out put control bits are written in real time any selection's effect can be seen in the path view panel or register map panel.

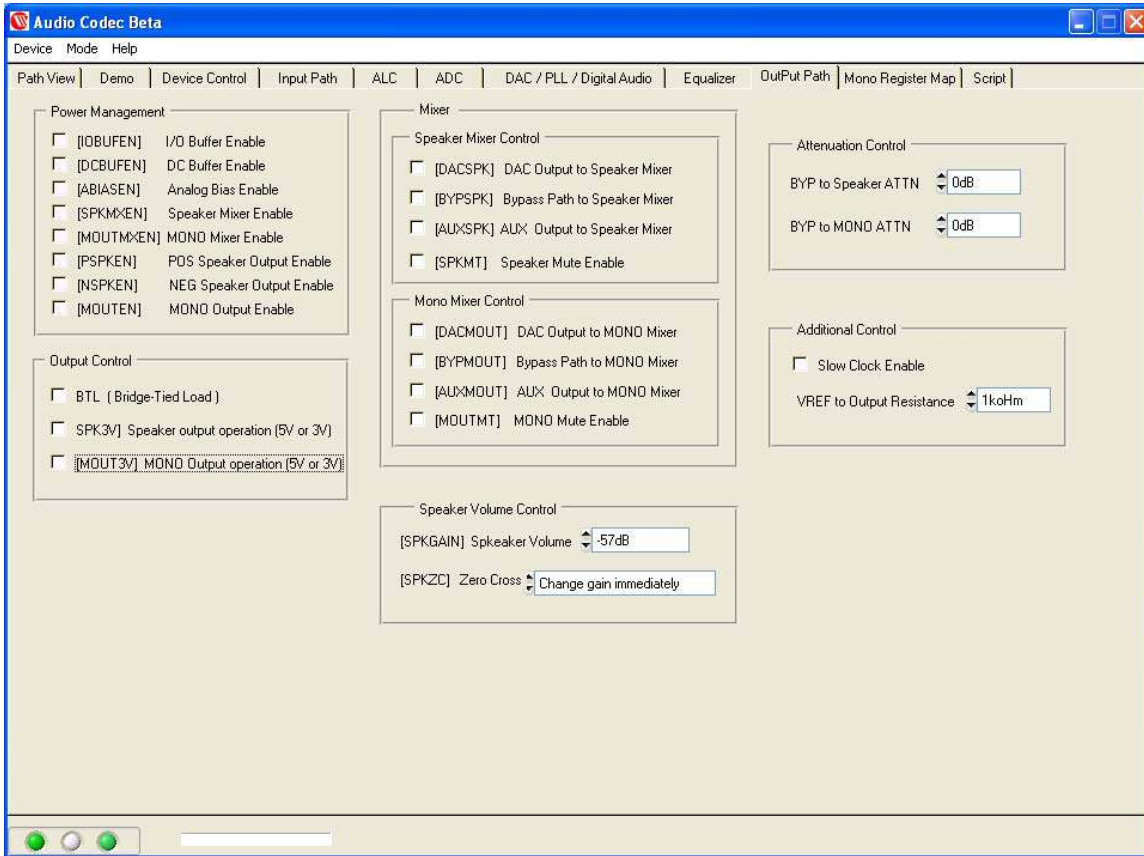

Register Map Panel:

In the Register map view all control address are in hex. To write to a particular register enter the register address followed by the registers new value and click write. The Read function works the same, enter a register address and click read, the value will be displayed in the register value box. You can also Read all and Update to see all register. To see individual register bit definitions click on WAU8822 Register Map box (1).

WAU8812 Register Map

	Addr	Bit 8	Bit 7	Bit 6	Bit 5	Bit 4	Bit 3	Bit 2	Bit 1	Bit 0	Hex Val
RST	0	0	0	0	0	0	0	0	0	0	0
PWRM1	1	0	0	0	0	0	0	0	0	0	0
PWRM2	2	0	0	0	0	0	0	0	0	0	0
PWRM3	3	0	0	0	0	0	0	0	0	0	0
AIF	4	0	0	0	0	0	0	0	0	0	0
CODEC	5	0	0	0	0	0	0	0	0	0	0
CLK	6	0	0	0	0	0	0	0	0	0	0
SR	7	1	0	0	0	0	0	0	0	0	100
GPIO	8	0	0	0	0	0	0	0	0	0	0
DACC	A	0	0	0	0	0	0	0	0	0	0
MN_DACG	B	0	0	0	0	0	0	0	0	0	0
ADCC	E	0	0	0	0	0	0	0	0	0	0
ADCG	F	0	0	0	0	0	0	0	0	0	0
EQ1L	12	0	0	0	0	0	0	0	0	0	0
EQ2P1	13	0	0	0	0	0	0	0	0	0	0
EQ3P2	14	0	0	0	0	0	0	0	0	0	0
EQ4P3	15	0	0	0	0	0	0	0	0	0	0
EQ5H	16	0	0	0	0	0	0	0	0	0	0
DACLIM1	18	0	0	0	0	0	0	0	0	0	0
DACLIM2	19	0	0	0	0	0	0	0	0	0	0
NF1	1B	0	0	0	0	0	0	0	0	0	0
NF2	1C	0	0	0	0	0	0	0	0	0	0
NF3	1D	0	0	0	0	0	0	0	0	0	0

Audio Codec Register Control

Register Address:

Register Value:

Script Panel:

This is a very useful feature if you know the values of each register and want to write all registers at once.

In pane **(1)** write the registers address followed by the register's value and select run. You can save the current screen into a file or load a different file to run by selecting save or load buttons.

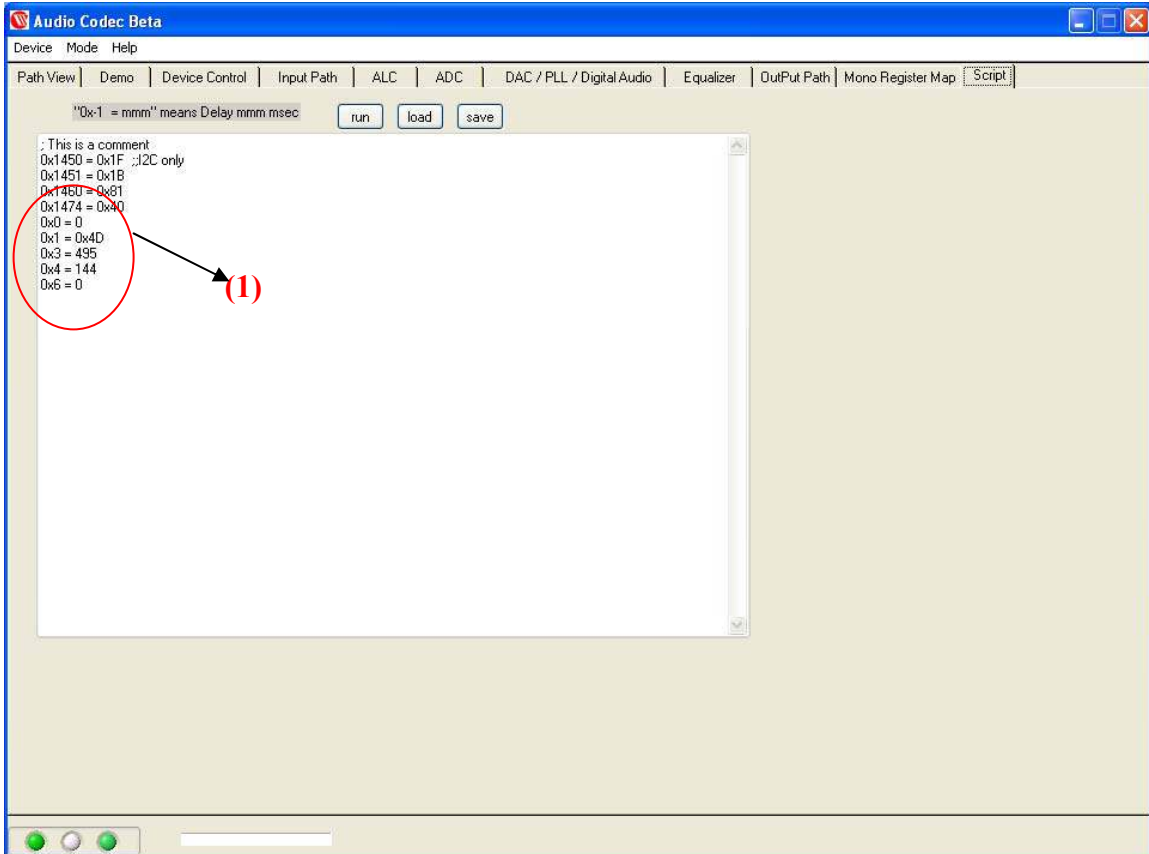

Analogue outputs:

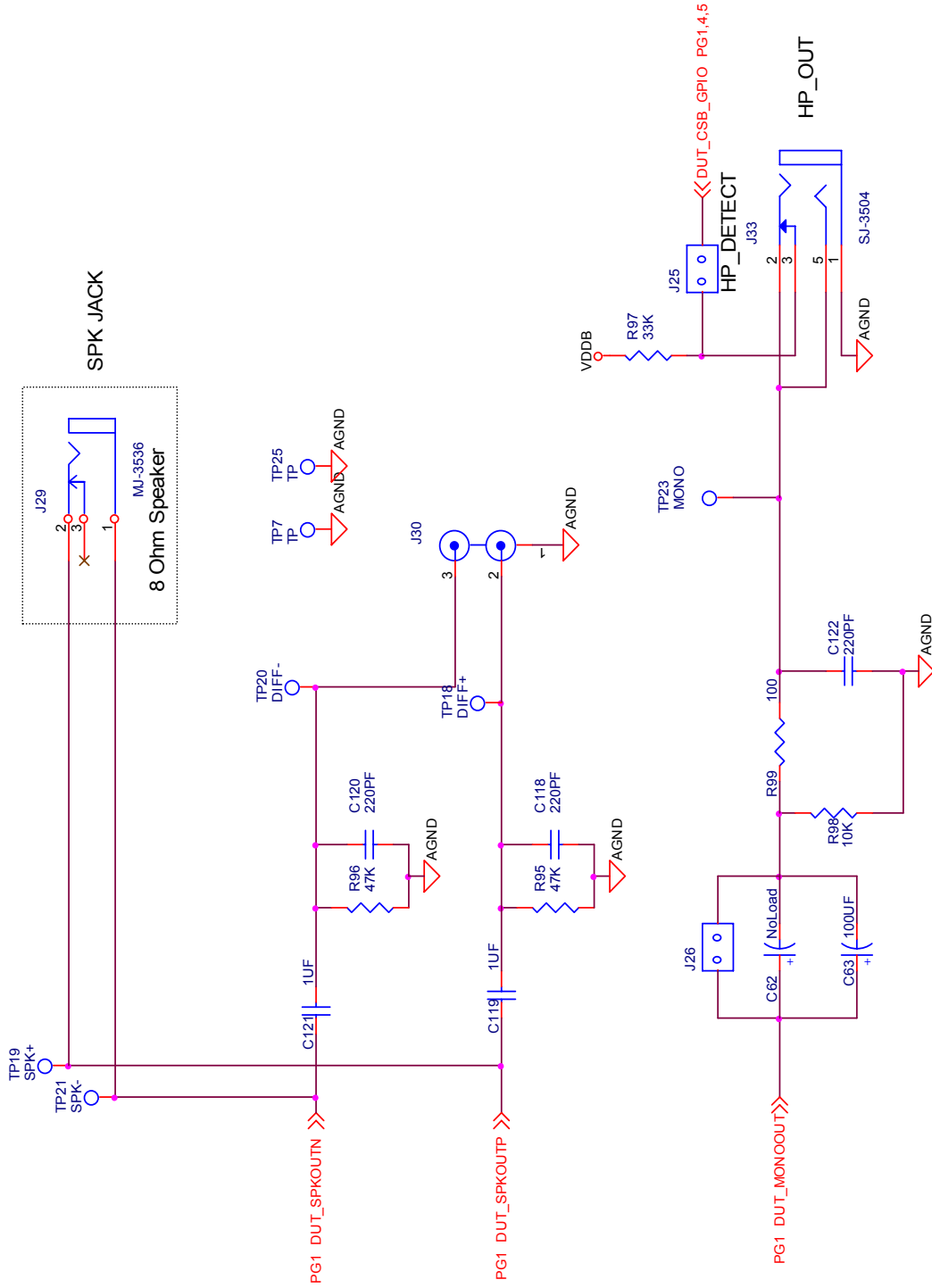

Level Translator:

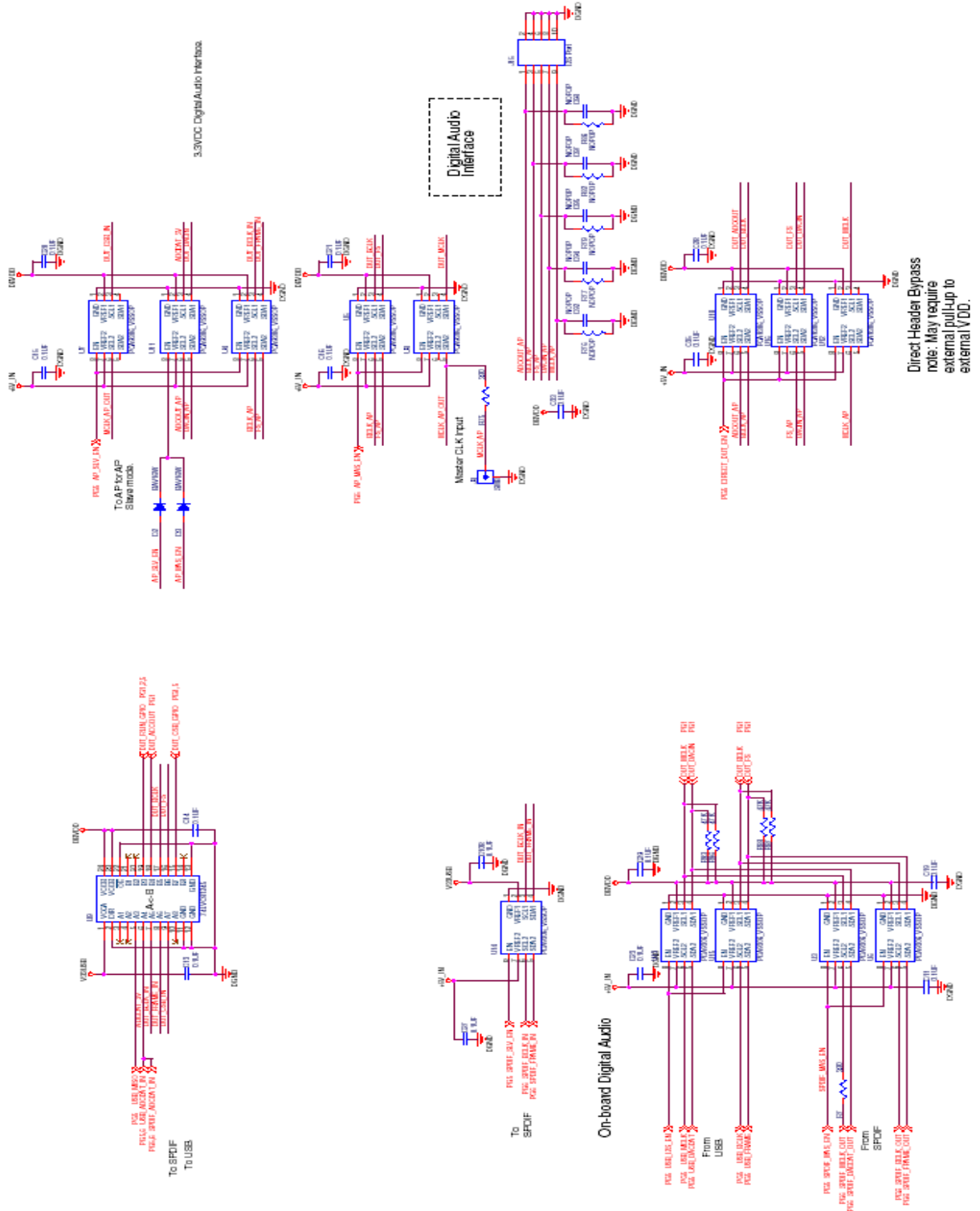

Analog inputs:

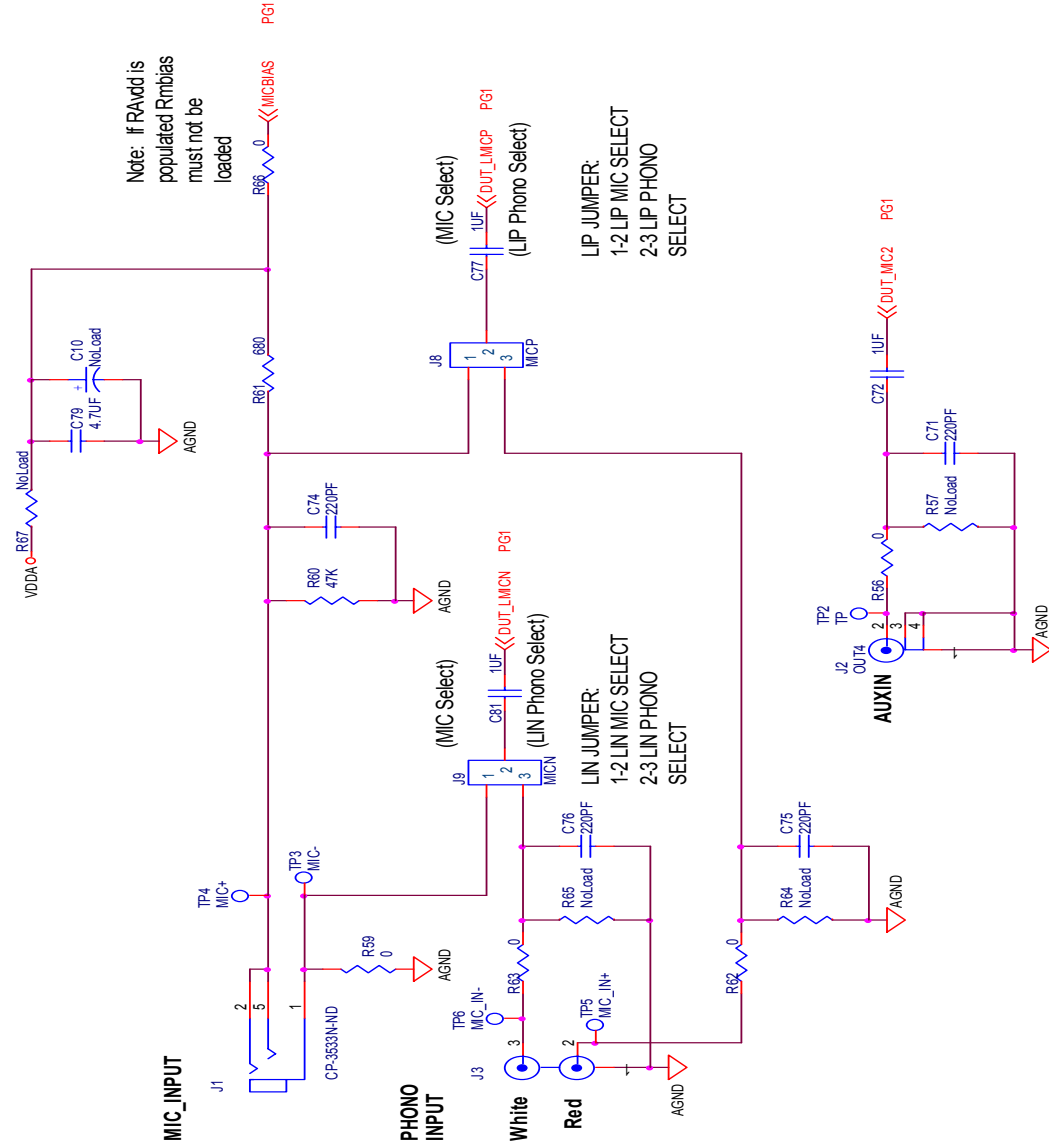

W861308 USB controller:

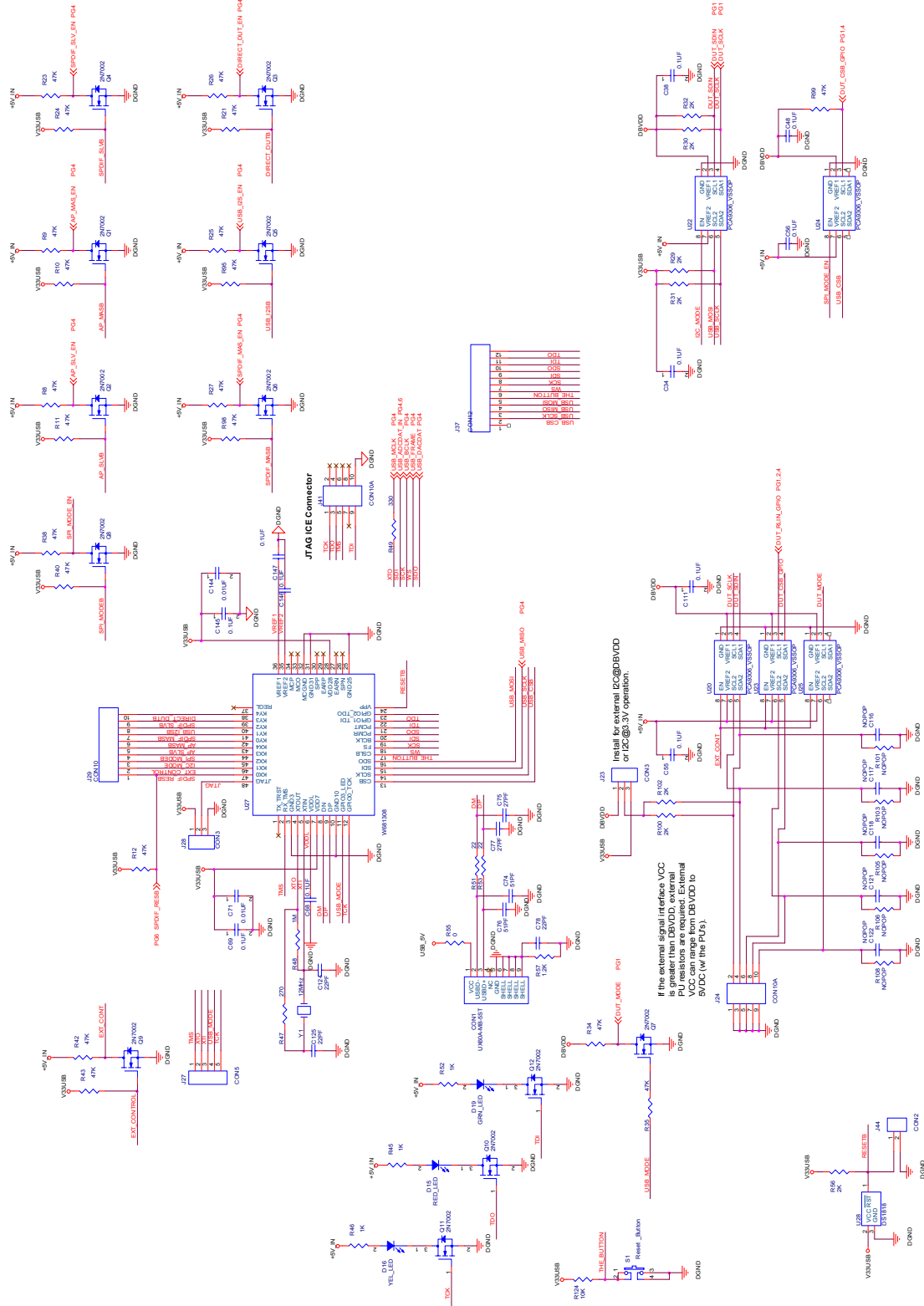

1. VERSION HISTORY

VERSION	DATE	PAGE	DESCRIPTION
0.2	August 20, 2008		Preliminary revision

Important Notice

Nuvoton products are not designed, intended, authorized or warranted for use as components in systems or equipment intended for surgical implantation, atomic energy control instruments, airplane or spaceship instruments, transportation instruments, traffic signal instruments, combustion control instruments, or for other applications intended to support or sustain life. Further more, Nuvoton products are not intended for applications wherein failure of Nuvoton products could result or lead to a situation wherein personal injury, death or severe property or environmental damage could occur.

Nuvoton customers using or selling these products for use in such applications do so at their own risk and agree to fully indemnify Nuvoton for any damages resulting from such improper use or sales.

The information contained in this document may be subject to change without notice. It is the responsibility of the customer to check the Nuvoton USA website (www.nuvoton.com) periodically for the latest version of this document, and any Errata Sheets that may be generated between document revisions.

Headquarters
No. 4, Creation Rd. III
Science-Based Industrial Park,
Hsinchu, Taiwan
TEL: 886-3-5770066
FAX: 886-3-5665577
<http://www.Nuvoton.com.tw/>

Nuvoton Electronics Corporation America
2727 North First Street, San Jose,
CA 95134, U.S.A.
TEL: 1-408-9436666
FAX: 1-408-5441798
<http://www.Nuvoton-usa.com/>

Nuvoton Electronics (Shanghai) Ltd.
27F, 299 Yan An W. Rd. Shanghai,
200336 China
TEL: 86-21-62365999
FAX: 86-21-62356998

Taipei Office
9F, No. 480, Pueiguang Rd.
Neihu District,
Taipei, 114, Taiwan
TEL: 886-2-8177168
FAX: 886-2-87153579

Nuvoton Electronics Corporation Japan
7F Daimi-ueno BLDG, 3-7-18
Shinyokohama Kohoku-ku,
Yokohama, 222-0033
TEL: 81-45-4781881
FAX: 81-45-4781800

Nuvoton Electronics (H.K.) Ltd.
Unit 9-15, 22F, Millennium City,
No. 378 Kwun Tong Rd.,
Kowloon, Hong Kong
TEL: 852-27513100
FAX: 852-27552064

Please note that all data and specifications are subject to change without notice.
All the trademarks of products and companies mentioned in this datasheet belong to their respective owners.