

SN74AVC4T234 4-Bit Dual-Supply Unidirectional Noninverting Voltage Translator

1 Features

- Wide operating V_{CC} range of 0.9 V to 3.6 V
- 3.6-V I/O Tolerant to support mixed-mode signal operation
- Max t_{pd} of 3.7 ns at 3.3 V
- Balanced propagation delays: $t_{PLH} = t_{PHL}$
- Low static-power consumption, 5- μ A Max I_{CC}
- Outputs disabled if either V_{CC} goes to 0V
- ± 3 -mA Output drive at 1.8 V
- 26- Ω series resistor on A-side outputs
- I_{off} supports partial power-down-mode operation
- Input hysteresis allows slow input transition and better switching noise immunity at input
- Maximum data rates
 - 380 Mbps (1.8-V to 3.3-V translation)
 - 200 Mbps (<1.8-V to 3.3-V translation)
 - 200 Mbps (translate to 2.5 V or 1.8 V)
 - 150 Mbps (translate to 1.5 V)
 - 100 Mbps (translate to 1.2 V)
- Latch-up performance exceeds 100 mA Per JESD 78, Class II
- ESD protection exceeds JESD 22
 - 2000-V human-body model (A114-A)
 - 500-V charged-device model (C101)

2 Applications

- Personal electronics
- Industrial
- Enterprise
- Telecom

3 Description

This 4-bit non-inverting bus transceiver uses two separate configurable power-supply rails to enable asynchronous communication between B-port inputs and A-port outputs. The A port is designed to track V_{CCA} while the B port is designed to track V_{CCB} . Both V_{CCA} and V_{CCB} are configurable from 0.9 V to 3.6 V.

The SN74AVC4T234 solution offers the industry's low-power needs in battery-powered portable applications by ensuring both a very low static and dynamic power consumption across the entire V_{CC} range of 0.9 V to 3.6 V, resulting in an increased battery life. This product also maintains excellent signal integrity.

This device is fully specified for partial-power-down applications using I_{off} . The I_{off} circuitry disables the outputs, preventing damaging current backflow through the device when it is powered down.

The V_{CC} isolation feature ensures that if either V_{CC} input is at GND, then A-side ports are in the high-impedance state.

Device Information

PART NUMBER	PACKAGE ⁽¹⁾	BODY SIZE (NOM)
SN74AVC4T234ZSU	uCSP (11)	2.00 mm × 1.40 mm
SN74AVC4T234ZWA	NFBGA (11)	2.00 mm × 1.40 mm

(1) For all available packages, see the orderable addendum at the end of the data sheet.

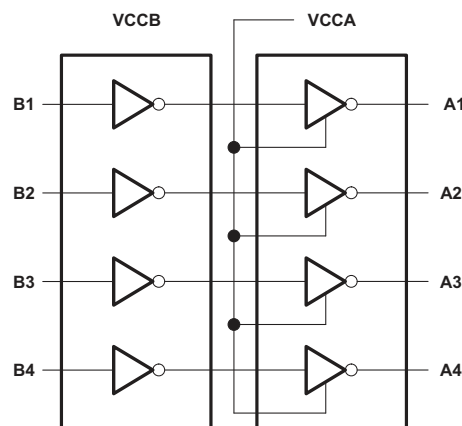

Logic Diagram (Positive Logic)



Table of Contents

1 Features	1	8 Detailed Description	10
2 Applications	1	8.1 Overview.....	10
3 Description	1	8.2 Functional Block Diagram.....	10
4 Revision History	2	8.3 Feature Description.....	10
5 Pin Configuration and Functions	3	8.4 Device Functional Modes.....	10
6 Specifications	4	9 Application and Implementation	11
6.1 Absolute Maximum Ratings.....	4	9.1 Application Information.....	11
6.2 ESD Ratings.....	4	9.2 Typical Application.....	11
6.3 Recommended Operating Conditions.....	5	10 Power Supply Recommendations	12
6.4 Thermal Information.....	6	11 Layout	12
6.5 Electrical Characteristics.....	6	11.1 Layout Guidelines.....	12
6.6 Switching Characteristics, $V_{CCB} = 1.1\text{ V}$	7	11.2 Layout Example.....	12
6.7 Switching Characteristics, $V_{CCB} = 1.4\text{ V}$	7	12 Device and Documentation Support	13
6.8 Switching Characteristics, $V_{CCB} = 1.65\text{ V}$	7	12.1 Support Resources.....	13
6.9 Switching Characteristics, $V_{CCB} = 2.3\text{ V}$	8	12.2 Trademarks.....	13
6.10 Switching Characteristics, $V_{CCB} = 3\text{ V}$	8	12.3 Electrostatic Discharge Caution.....	13
6.11 Operating Characteristics.....	8	12.4 Glossary.....	13
7 Parameter Measurement Information	9	13 Mechanical, Packaging, and Orderable Information	13
7.1 Load Circuit and Voltage Waveforms.....	9		

4 Revision History

NOTE: Page numbers for previous revisions may differ from page numbers in the current version.

Changes from Revision A (June 2011) to Revision B (July 2020)	Page
• Format to new TI data sheet standard with additional information throughout	1
• Removed Feature "Input-Disabled Feature Allows Floating Input Conditions".....	1
• Added Feature "Outputs Disabled if Either V_{CC} goes to 0V".....	1
• Updated the numbering format for tables, figures and cross-references throughout.....	1
• Removed <i>Ordering Information</i> table	1
• Added ZWA package as orderable	1
• Added <i>ESD Ratings</i> table.....	4
• Added <i>Thermal Information</i> table.....	6
• Added <i>Feature Description</i> section.	10
• Added <i>Device Functional Modes</i> section.....	10
• Added <i>Application and Implementation</i> section.....	11
• Added <i>Power Supply Recommendations</i> section.....	12
• Added <i>Layout</i> section.....	12
• Added <i>Device and Documentation Support</i> , and <i>Mechanical, Packaging, and Orderable Information</i> sections.	13

5 Pin Configuration and Functions

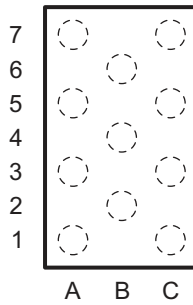

Figure 5-1. ZSU/ZWA Package 11-Pin uCSP Transparent Top View

Pin Functions

PIN NAME	NO. ZSU, ZWA	TYPE	DESCRIPTION
B1	C7	I	Channel 1 Data input port
B2	C5	I	Channel 2 Data input port
B3	C3	I	Channel 3 Data input port
B4	C1	I	Channel 4 Data input port
A1	A7	O	Channel 1 Data output port
A2	A5	O	Channel 2 Data output port
A3	A3	O	Channel 3 Data output port
A4	A1	O	Channel 4 Data output port
V _{CCA}	B6	—	A-side output port power supply voltage (0.9 V to 3.6 V)
V _{CCB}	B4	—	B-side input port power supply voltage (0.9 V to 3.6 V)
GND	B2	—	Ground

6 Specifications

6.1 Absolute Maximum Ratings

over operating free-air temperature range (unless otherwise noted)⁽¹⁾

		MIN	MAX	UNIT	
V_{CCA} V_{CCB}	Supply voltage	-0.5	4.6	V	
V_I	Input voltage ⁽²⁾	Output ports (A port)	-0.5	4.6	V
		Input ports (B port)	-0.5	4.6	
V_O	Voltage applied to any output in the high-impedance or power-off state ⁽²⁾	A port	-0.5	4.6	V
V_O	Voltage applied to any output in the high or low state ^{(2) (3)}	A port	-0.5	$V_{CCA} + 0.5$	V
I_{IK}	Input clamp current	$V_I < 0$	-50		mA
I_{OK}	Output clamp current	$V_O < 0$	-50		mA
I_O	Continuous output current		±20		mA
	Continuous current through V_{CCA} , V_{CCB} , or GND		±50		mA
T_{stg}	Storage temperature	-65	150		°C

- (1) Stresses beyond those listed under *Absolute Maximum Ratings* may cause permanent damage to the device. These are stress ratings only, which do not imply functional operation of the device at these or any other conditions beyond those indicated under *Recommended Operating Conditions*. Exposure to absolute-maximum-rated conditions for extended periods may affect device reliability.
- (2) The input voltage and output negative-voltage ratings may be exceeded if the input and output current ratings are observed.
- (3) The output positive-voltage rating may be exceeded up to 4.6 V maximum if the output current rating is observed.

6.2 ESD Ratings

		VALUE	UNIT	
$V_{(ESD)}$	Electrostatic discharge	Human-body model (HBM), per ANSI/ESDA/JEDEC JS-001 ⁽¹⁾	±2000	V
		Charged-device model (CDM), per JEDEC specification JESD22-C101 ⁽²⁾	±500	

- (1) JEDEC document JEP155 states that 500-V HBM allows safe manufacturing with a standard ESD control process.
- (2) JEDEC document JEP157 states that 250-V CDM allows safe manufacturing with a standard ESD control process.

6.3 Recommended Operating Conditions

		V_{CCI} ^{(1) (3)}	V_{CCO} ⁽²⁾	MIN	MAX	UNIT
V_{CCA}	Supply voltage			0.9	3.6	V
V_{CCB}	Supply voltage			0.9	3.6	V
V_{IH}	High-level input voltage	Data inputs ⁽⁴⁾	0.9 V to 1.1 V	$V_{CCI} \times 0.8$	3.6	V
			1.1 V to 1.4 V	$V_{CCI} \times 0.8$	3.6	
			1.4 V to 1.95 V	$V_{CCI} \times 0.65$	3.6	
			2.3 V to 2.7 V	$V_{CCI} \times 0.65$	3.6	
			3 V to 3.6 V	$V_{CCI} \times 0.65$	3.6	
V_{IL}	Low-level input voltage	Data inputs ⁽⁴⁾	0.9 V to 1.1 V	0	$V_{CCI} \times 0.2$	V
			1.1 V to 1.4 V	0	$V_{CCI} \times 0.2$	
			1.1 V to 1.95 V	0	$V_{CCI} \times 0.35$	
			2.3 V to 2.7 V	0	$V_{CCI} \times 0.35$	
			3 V to 3.6 V	0	$V_{CCI} \times 0.35$	
V_I	Input voltage			0	3.6	V
V_O	Output voltage	Active state		0	V_{CCO}	V
I_{OH}	High-level output current		0.9 V to 1.1 V		-0.1	mA
			1.1 V to 1.3 V		-1	
			1.4 V to 1.6 V		-2	
			1.65 V to 1.95 V		-3	
			2.3 V to 2.7 V		-6	
			3 V to 3.6 V		-12	
I_{OL}	Low-level output current		0.9 V to 1.1 V		0.1	mA
			1.1 V to 1.3 V		1	
			1.4 V to 1.6 V		2	
			1.65 V to 1.95 V		3	
			2.3 V to 2.7 V		6	
			3 V to 3.6 V		12	
$\Delta t/\Delta v$	Input transition rise or fall rate		3 V to 3.6 V		10	ns/V
			2.3 V to 2.7 V		20	
			1.65 V to 1.95 V		50	
			1.4 V to 1.6 V		100	
			1.1 V to 1.3 V		100	
T_A	Operating free-air temperature			-40	85	°C

- (1) V_{CCI} is the V_{CCB} input port.
- (2) V_{CCO} is the V_{CCA} output port.
- (3) All unused data inputs of the device must be held at V_{CCI} or GND to ensure proper device operation. Refer to the TI application report, *Implications of Slow or Floating CMOS Inputs*, [SCBA004](#).
- (4) For V_{CCI} values not specified in the data sheet, $V_{IH} \text{ min} = V_{CCI} \times 0.7 \text{ V}$, $V_{IL} \text{ max} = V_{CCI} \times 0.3 \text{ V}$

6.4 Thermal Information

THERMAL METRIC ⁽¹⁾		SN74AVC4T234	SN74AVC4T234	UNIT
		ZSU (μCSP)	ZWA (NFBGA)	
		11 PINS	11 PINS	
R _{θJA}	Junction-to-ambient thermal resistance ⁽²⁾	165.9	181.4	°C/W
R _{θJC(top)}	Junction-to-case (top) thermal resistance	123.8	136.7	°C/W
R _{θJB}	Junction-to-board thermal resistance	123.2	137.7	°C/W
ψ _{JT}	Junction-to-top characterization parameter	4.4	7.5	°C/W
ψ _{JB}	Junction-to-board characterization parameter	122.9	137.4	°C/W

- (1) For more information about traditional and new thermal metrics, see the *Semiconductor and IC Package Thermal Metrics* application report, [SPRA953](#).
- (2) The package thermal impedance is calculated in accordance with JESD 51-5.

6.5 Electrical Characteristics

over recommended operating free-air temperature range (unless otherwise noted)

PARAMETER ^{(1) (2)}		TEST CONDITIONS	V _{CCA}	V _{CCB}	T _A	MIN	TYP	MAX	UNIT
V _{OH}		I _{OH} = -100 μA I _{OH} = -1 mA I _{OH} = -2 mA I _{OH} = -3 mA I _{OH} = -6 mA I _{OH} = -12 mA	V _I = V _{IH}	0.9 V	0.9 V to 3.6 V	T _A = -40°C to 85°C	V _{CCA} - 0.1		V
				1.1 V			0.88		
				1.4 V			1.05		
				1.65 V			1.2		
				2.3V			1.75		
				3 V			2.3		
V _{OL}		I _{OL} = 100 μA I _{OL} = 1 mA I _{OL} = 2 mA I _{OL} = 3 mA I _{OL} = 6 mA I _{OL} = 12 mA	V _I = V _{IL}	0.9 V	0.9 V to 3.6 V	T _A = -40°C to 85°C	0.1		V
				1.1 V			0.2		
				1.4 V			0.2		
				1.65 V			0.25		
				2.3V			0.3		
				3 V			0.55		
I _{off}	A or B port	V _I or V _O = 0 to 3.6 V	0 V	0 V to 3.6 V	T _A = 25°C	±0.1	±1	μA	
					T _A = -40°C to 85°C		±5		
					T _A = 25°C	±0.1	±1		
					T _A = -40°C to 85°C		±5		
I _{CCA}		V _{CCB} or GND, I _O = 0	0.8 V to 3.6 V	0.8 V to 3.6 V	T _A = -40°C to 85°C	8		μA	
			0 V	0 V to 3.6 V	T _A = -40°C to 85°C	8			
			0 V to 3.6 V	0 V	T _A = -40°C to 85°C	8			
I _{CCB}		V _{CCB} or GND, I _O = 0	0.8 V to 3.6 V	0.8 V to 3.6 V	T _A = -40°C to 85°C	8		μA	
			0 V	0 V to 3.6 V	T _A = -40°C to 85°C	8			
			0 V to 3.6 V	0 V	T _A = -40°C to 85°C	8			
I _{CCA} + I _{CCB}		V _{CCB} or GND, I _O = 0	0.8 V to 3.6 V	0.8 V to 3.6 V	T _A = -40°C to 85°C	16		μA	
C _i	V _{CCB}	V _{CCB} = 3.3 V or GND	3.3 V	3.3 V	T _A = 25°C	22		pF	
C _{io}	A or B port	V _{CCA} = 3.3 V or GND	3.3 V	3.3 V	T _A = 25°C	5		pF	
					T _A = -40°C to 85°C	7			

- (1) V_{CCI} is the V_{CCB} input port.
- (2) V_{CCO} is the V_{CCA} output port.

6.6 Switching Characteristics, $V_{CCB} = 1.1\text{ V}$

over recommended operating free-air temperature range, $V_{CCB} = 1.1\text{ V}$ (unless otherwise noted) (see [Figure 7-1](#))

PARAMETER	FROM (INPUT)	TO (OUTPUT)	V_{CCA}	TYP	UNIT
t_{PLH}	B	A	$V_{CCA} = 1.1\text{ V}$	5.5	ns
			$V_{CCA} = 1.4\text{ V}$	4.6	
			$V_{CCA} = 1.65\text{ V}$	4.2	
			$V_{CCA} = 2.3\text{ V}$	3.7	
			$V_{CCA} = 3\text{ V}$	3.9	
t_{PHL}	B	A	$V_{CCA} = 1.1\text{ V}$	4.7	ns
			$V_{CCA} = 1.4\text{ V}$	3.9	
			$V_{CCA} = 1.65\text{ V}$	3.4	
			$V_{CCA} = 2.3\text{ V}$	3	
			$V_{CCA} = 3\text{ V}$	3.1	

6.7 Switching Characteristics, $V_{CCB} = 1.4\text{ V}$

over recommended operating free-air temperature range, $V_{CCB} = 1.4\text{ V}$ (see [Figure 7-1](#))

PARAMETER	FROM (INPUT)	TO (OUTPUT)	V_{CCA}	MIN	TYP	MAX	UNIT
t_{PLH}	B	A	$V_{CCA} = 1.1\text{ V}$		4.7		ns
			$V_{CCA} = 1.4\text{ V}$	2		5	
			$V_{CCA} = 1.65\text{ V}$	1.5		3.8	
			$V_{CCA} = 2.3\text{ V}$	1.2		3.8	
			$V_{CCA} = 3\text{ V}$	1		3.8	
t_{PHL}	B	A	$V_{CCA} = 1.1\text{ V}$		4.2		ns
			$V_{CCA} = 1.4\text{ V}$	2		5	
			$V_{CCA} = 1.65\text{ V}$	1.5		3.9	
			$V_{CCA} = 2.3\text{ V}$	1.2		3	
			$V_{CCA} = 3\text{ V}$	1		3	

6.8 Switching Characteristics, $V_{CCB} = 1.65\text{ V}$

over recommended operating free-air temperature range, $V_{CCB} = 1.65\text{ V}$ (see [Figure 7-1](#))

PARAMETER	FROM (INPUT)	TO (OUTPUT)	V_{CCA}	MIN	TYP	MAX	UNIT
t_{PLH}	B	A	$V_{CCA} = 1.1\text{ V}$		4.3		ns
			$V_{CCA} = 1.4\text{ V}$	2		4.2	
			$V_{CCA} = 1.65\text{ V}$	1.5		4.1	
			$V_{CCA} = 2.3\text{ V}$	1.2		3.8	
			$V_{CCA} = 3\text{ V}$	1		3.7	
t_{PHL}	B	A	$V_{CCA} = 1.1\text{ V}$		2.6		ns
			$V_{CCA} = 1.4\text{ V}$	2		4.2	
			$V_{CCA} = 1.65\text{ V}$	1.5		4.1	
			$V_{CCA} = 2.3\text{ V}$	1.2		3.8	
			$V_{CCA} = 3\text{ V}$	1		3.7	

6.9 Switching Characteristics, $V_{CCB} = 2.3\text{ V}$

over recommended operating free-air temperature range, $V_{CCB} = 2.3\text{ V}$ (see [Figure 7-1](#))

PARAMETER	FROM (INPUT)	TO (OUTPUT)	V_{CCA}	MIN	TYP	MAX	UNIT
t_{PLH}	B	A	$V_{CCA} = 1.1\text{ V}$		2.7		ns
			$V_{CCA} = 1.4\text{ V}$	2		3.5	
			$V_{CCA} = 1.65\text{ V}$	1.5		3.1	
			$V_{CCA} = 2.3\text{ V}$	1.2		2.8	
			$V_{CCA} = 3\text{ V}$	0.2		4.1	
t_{PHL}	B	A	$V_{CCA} = 1.1\text{ V}$		2.4		ns
			$V_{CCA} = 1.4\text{ V}$	2		3.7	
			$V_{CCA} = 1.65\text{ V}$	1.5		3.7	
			$V_{CCA} = 2.3\text{ V}$	1.2		2.8	
			$V_{CCA} = 3\text{ V}$	0.2		3.5	

6.10 Switching Characteristics, $V_{CCB} = 3\text{ V}$

over recommended operating free-air temperature range, $V_{CCB} = 3\text{ V}$ (see [Figure 7-1](#))

PARAMETER	FROM (INPUT)	TO (OUTPUT)	V_{CCA}	MIN	TYP	MAX	UNIT
t_{PLH}	B	A	$V_{CCA} = 1.1\text{ V}$		3.9		ns
			$V_{CCA} = 1.4\text{ V}$	2		3.8	
			$V_{CCA} = 1.65\text{ V}$	1.5		3.6	
			$V_{CCA} = 2.3\text{ V}$	0.5		3.6	
			$V_{CCA} = 3\text{ V}$	0.2		3.6	
t_{PHL}	B	A	$V_{CCA} = 1.1\text{ V}$		3.9		ns
			$V_{CCA} = 1.4\text{ V}$	2		3.7	
			$V_{CCA} = 1.65\text{ V}$	1.5		3.1	
			$V_{CCA} = 2.3\text{ V}$	0.5		3.5	
			$V_{CCA} = 3\text{ V}$	0.2		3	

6.11 Operating Characteristics

$T_A = 25^\circ\text{C}$

PARAMETER			TEST CONDITIONS	V_{CCA}, V_{CCB}	TYP	UNIT
C_{pdA} ⁽¹⁾	B to A	Outputs enabled	$C_L = 0,$ $f = 10\text{ MHz},$ $t_r = t_f = 1\text{ ns}$	$V_{CCA} = V_{CCB} = 1.1\text{ V}$	18.5	pF
				$V_{CCA} = V_{CCB} = 1.4\text{ V}$		
				$V_{CCA} = V_{CCB} = 1.65\text{ V}$		
				$V_{CCA} = V_{CCB} = 2.3\text{ V}$		
				$V_{CCA} = V_{CCB} = 3\text{ V}$		

(1) Power dissipation capacitance per transceiver

7 Parameter Measurement Information

7.1 Load Circuit and Voltage Waveforms

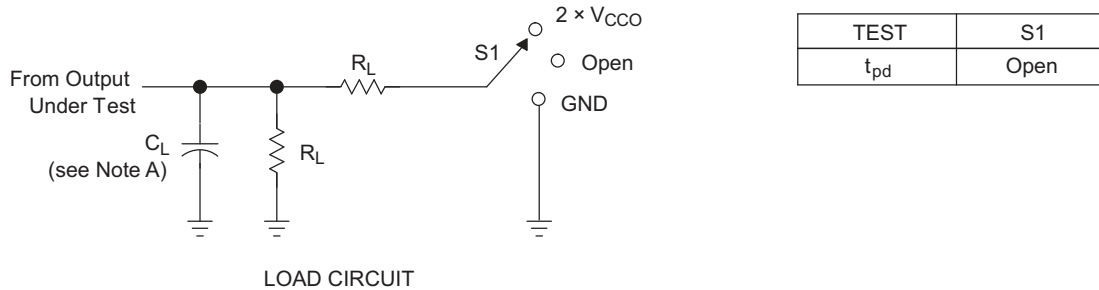

V_{CCO}	C_L	R_L	V_{TP}
1.2 V	30 pF	0.5 k Ω	0.1 V
1.5 V \pm 0.1 V	30 pF	0.5 k Ω	0.1 V
1.8 V \pm 0.15 V	30 pF	0.5 k Ω	0.15 V
2.5 V \pm 0.2 V	30 pF	0.5 k Ω	0.15 V
3.3 V \pm 0.3 V	30 pF	0.5 k Ω	0.3 V

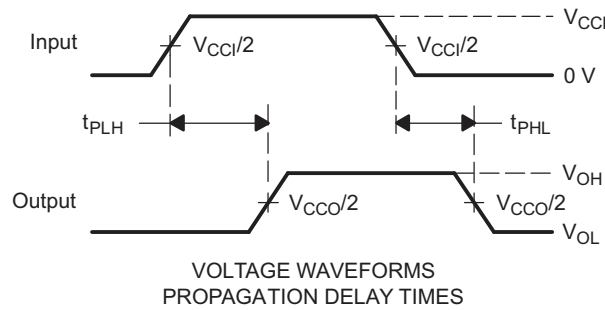

- NOTES:
- A. C_L includes probe and jig capacitance.
 - B. All input pulses are supplied by generators having the following characteristics: $PRR \leq 10$ MHz, $Z_O = 50 \Omega$, $dv/dt \geq 1$ V/ns.
 - C. The outputs are measured one at a time, with one transition per measurement.
 - D. t_{PLH} and t_{PHL} are the same as t_{pd} .
 - E. V_{CCi} is V_{CCB} .
 - F. V_{CCo} is V_{CCA} .

Figure 7-1. Load and Circuit and Voltage Waveforms

8 Detailed Description

8.1 Overview

The SN74AVC4T234 is a 4-bit, dual-supply noninverting voltage level translation device. The B input port pins are referenced to the V_{CCB} supply, and the A output port pins are referenced to the V_{CCA} . The B port is able to accept I/O voltages ranging from 0.9 V to 3.6 V.

8.2 Functional Block Diagram

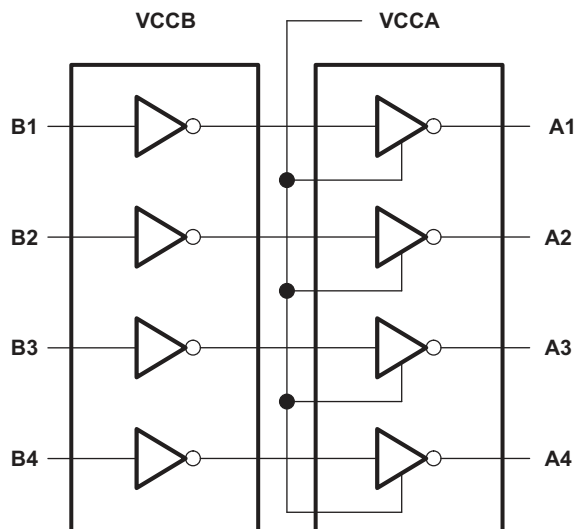

Figure 8-1. Logic Diagram (Positive Logic)

8.3 Feature Description

8.3.1 Fully Configurable Dual-Rail Design Allows Each Port to Operate Over the Full 0.9-V to 3.6-V Power-Supply Range

Both V_{CCA} and V_{CCB} can be supplied at any voltage between 0.9 V and 3.6 V; thus, making the device suitable for translating between any of the low voltage nodes (0.9, 1.05 V, 1.2 V, 1.8 V, 2.5 V, and 3.3 V).

8.3.2 Supports High Speed Translation

The SN74AVC4T234 device can support high data rate applications. The translated signal data rate can be up to 380 Mbps when the signal is translated from 1.8 V to 3.3 V.

8.3.3 I_{off} Supports Partial-Power-Down Mode Operation

I_{off} will prevent backflow current by disabling I/O output circuits when device is in partial-power-down mode.

8.4 Device Functional Modes

Table 8-1. Function Table

INPUTS	OUTPUTS
Bx	Ax
L	L
H (referenced to V_{CCB})	H (referenced to V_{CCA})

9 Application and Implementation

Note

Information in the following applications sections is not part of the TI component specification, and TI does not warrant its accuracy or completeness. TI's customers are responsible for determining suitability of components for their purposes. Customers should validate and test their design implementation to confirm system functionality.

9.1 Application Information

The SN74AVC4T234 device can be used in level-translation applications for interfacing devices or systems operating at different interface voltages with one another. The SN74AVC4T234 device is ideal for use in applications where a push-pull driver is connected to the data I/Os. The max data rate can be up to 380 Mbps when device translates a signal from 1.8 V to 3.3 V.

9.2 Typical Application

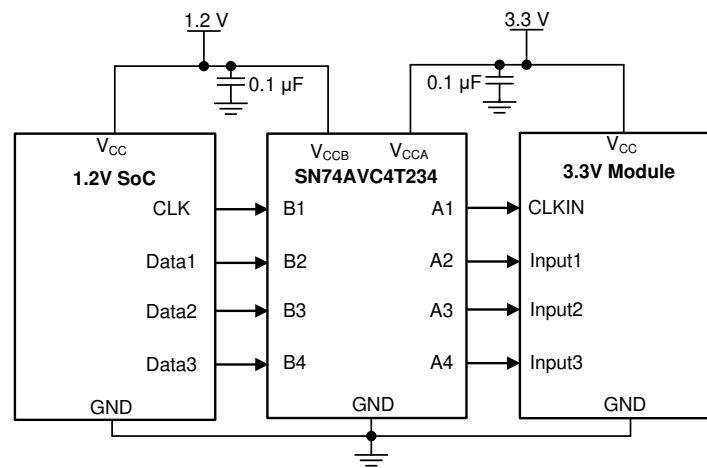

Figure 9-1. Typical Application Diagram

9.2.1 Design Requirements

For the design example shown in [Typical Application](#), use the parameters listed in [Table 9-1](#).

Table 9-1. Design Parameters

DESIGN PARAMETER	EXAMPLE VALUE
Input voltage range	0.9 V to 3.6 V
Output voltage range	0.9 V to 3.6 V

9.2.2 Detailed Design Procedure

To begin the design process, determine the following:

- Input voltage range
 - Use the supply voltage of the device that is driving the SN74AVC4T234 device to determine the input voltage range. For a valid logic high, the value must exceed the V_{IH} of the input port. For a valid logic low, the value must be less than the V_{IL} of the input port.
- Output voltage range
 - Use the supply voltage of the device that the SN74AVC4T234 device is driving to determine the output voltage range.

9.2.3 Application Curves

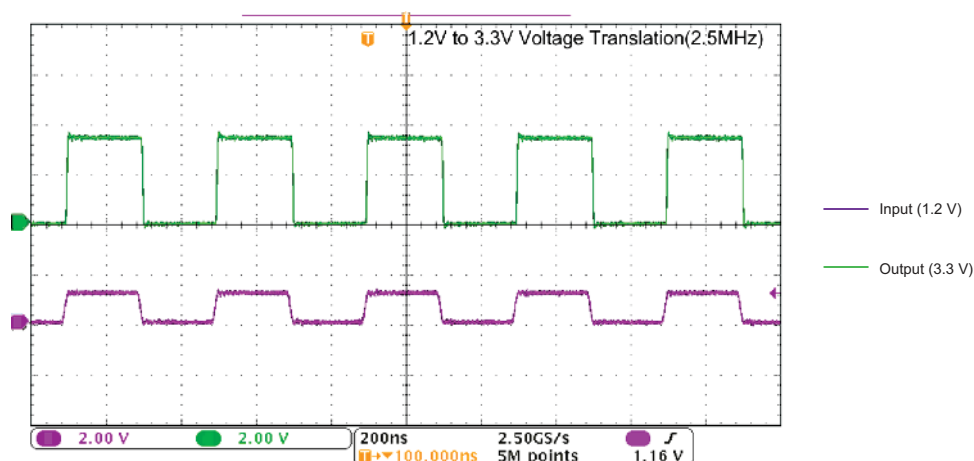

Figure 9-2. Translation Up (1.2 V to 3.3 V) at 2.5 MHz

10 Power Supply Recommendations

The SN74AVC4T234 device uses two separate configurable power-supply rails, V_{CCA} and V_{CCB} . V_{CCA} accepts any supply voltage from 0.9 V to 3.6 V and V_{CCB} accepts any supply voltage from 0.9 V to 3.6 V. The A port and B port are designed to track V_{CCA} and V_{CCB} respectively allowing for low-voltage bidirectional translation between any of the 0.9-V, 1.05-V, 1.2-V, 1.5-V, 1.8-V, 2.5-V and 3.3-V voltage nodes.

11 Layout

11.1 Layout Guidelines

To ensure reliability of the device, following common printed-circuit board layout guidelines is recommended.

- Bypass capacitors should be used on power supplies.
- Short trace lengths should be used to avoid excessive loading.
- Place pads on the signal paths for loading capacitors or pullup resistors to help adjust rise and fall times of signals, depending on the system requirements.

11.2 Layout Example

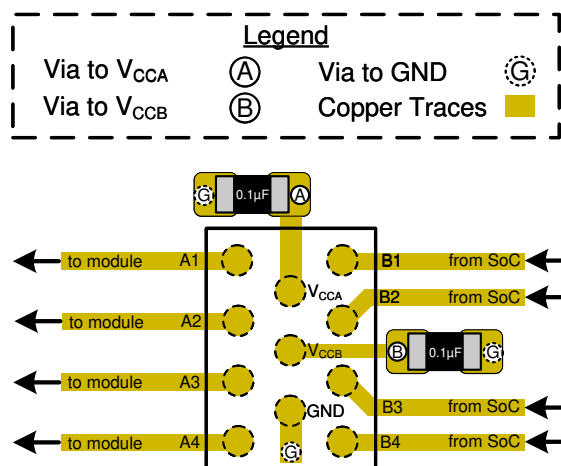

12 Device and Documentation Support

12.1 Support Resources

[TI E2E™ support forums](#) are an engineer's go-to source for fast, verified answers and design help — straight from the experts. Search existing answers or ask your own question to get the quick design help you need.

Linked content is provided "AS IS" by the respective contributors. They do not constitute TI specifications and do not necessarily reflect TI's views; see TI's [Terms of Use](#).

12.2 Trademarks

TI E2E™ is a trademark of Texas Instruments Incorporated.
All other trademarks are the property of their respective owners.

12.3 Electrostatic Discharge Caution



This integrated circuit can be damaged by ESD. Texas Instruments recommends that all integrated circuits be handled with appropriate precautions. Failure to observe proper handling and installation procedures can cause damage.

ESD damage can range from subtle performance degradation to complete device failure. Precision integrated circuits may be more susceptible to damage because very small parametric changes could cause the device not to meet its published specifications.

12.4 Glossary

[TI Glossary](#) This glossary lists and explains terms, acronyms, and definitions.

13 Mechanical, Packaging, and Orderable Information

The following pages include mechanical, packaging, and orderable information. This information is the most current data available for the designated devices. This data is subject to change without notice and revision of this document. For browser-based versions of this data sheet, refer to the left-hand navigation.

PACKAGING INFORMATION

Orderable Device	Status (1)	Package Type	Package Drawing	Pins	Package Qty	Eco Plan (2)	Lead finish/ Ball material (6)	MSL Peak Temp (3)	Op Temp (°C)	Device Marking (4/5)	Samples
SN74AVC4T234ZWAR	ACTIVE	NFBGA	ZWA	11	2500	RoHS & Green	SN98.5/AG1/CU0.5	Level-2-260C-1 YEAR	-40 to 85	1G2	Samples

(1) The marketing status values are defined as follows:

ACTIVE: Product device recommended for new designs.

LIFEBUY: TI has announced that the device will be discontinued, and a lifetime-buy period is in effect.

NRND: Not recommended for new designs. Device is in production to support existing customers, but TI does not recommend using this part in a new design.

PREVIEW: Device has been announced but is not in production. Samples may or may not be available.

OBSOLETE: TI has discontinued the production of the device.

(2) **RoHS:** TI defines "RoHS" to mean semiconductor products that are compliant with the current EU RoHS requirements for all 10 RoHS substances, including the requirement that RoHS substance do not exceed 0.1% by weight in homogeneous materials. Where designed to be soldered at high temperatures, "RoHS" products are suitable for use in specified lead-free processes. TI may reference these types of products as "Pb-Free".

RoHS Exempt: TI defines "RoHS Exempt" to mean products that contain lead but are compliant with EU RoHS pursuant to a specific EU RoHS exemption.

Green: TI defines "Green" to mean the content of Chlorine (Cl) and Bromine (Br) based flame retardants meet JS709B low halogen requirements of <=1000ppm threshold. Antimony trioxide based flame retardants must also meet the <=1000ppm threshold requirement.

(3) MSL, Peak Temp. - The Moisture Sensitivity Level rating according to the JEDEC industry standard classifications, and peak solder temperature.

(4) There may be additional marking, which relates to the logo, the lot trace code information, or the environmental category on the device.

(5) Multiple Device Markings will be inside parentheses. Only one Device Marking contained in parentheses and separated by a "-" will appear on a device. If a line is indented then it is a continuation of the previous line and the two combined represent the entire Device Marking for that device.

(6) Lead finish/Ball material - Orderable Devices may have multiple material finish options. Finish options are separated by a vertical ruled line. Lead finish/Ball material values may wrap to two lines if the finish value exceeds the maximum column width.

Important Information and Disclaimer:The information provided on this page represents TI's knowledge and belief as of the date that it is provided. TI bases its knowledge and belief on information provided by third parties, and makes no representation or warranty as to the accuracy of such information. Efforts are underway to better integrate information from third parties. TI has taken and continues to take reasonable steps to provide representative and accurate information but may not have conducted destructive testing or chemical analysis on incoming materials and chemicals. TI and TI suppliers consider certain information to be proprietary, and thus CAS numbers and other limited information may not be available for release.

In no event shall TI's liability arising out of such information exceed the total purchase price of the TI part(s) at issue in this document sold by TI to Customer on an annual basis.

TAPE AND REEL INFORMATION

QUADRANT ASSIGNMENTS FOR PIN 1 ORIENTATION IN TAPE



*All dimensions are nominal

Device	Package Type	Package Drawing	Pins	SPQ	Reel Diameter (mm)	Reel Width W1 (mm)	A0 (mm)	B0 (mm)	K0 (mm)	P1 (mm)	W (mm)	Pin1 Quadrant
SN74AVC4T234ZWAR	NFBGA	ZWA	11	2500	330.0	8.4	1.6	2.2	0.55	4.0	8.0	Q2

TAPE AND REEL BOX DIMENSIONS

*All dimensions are nominal

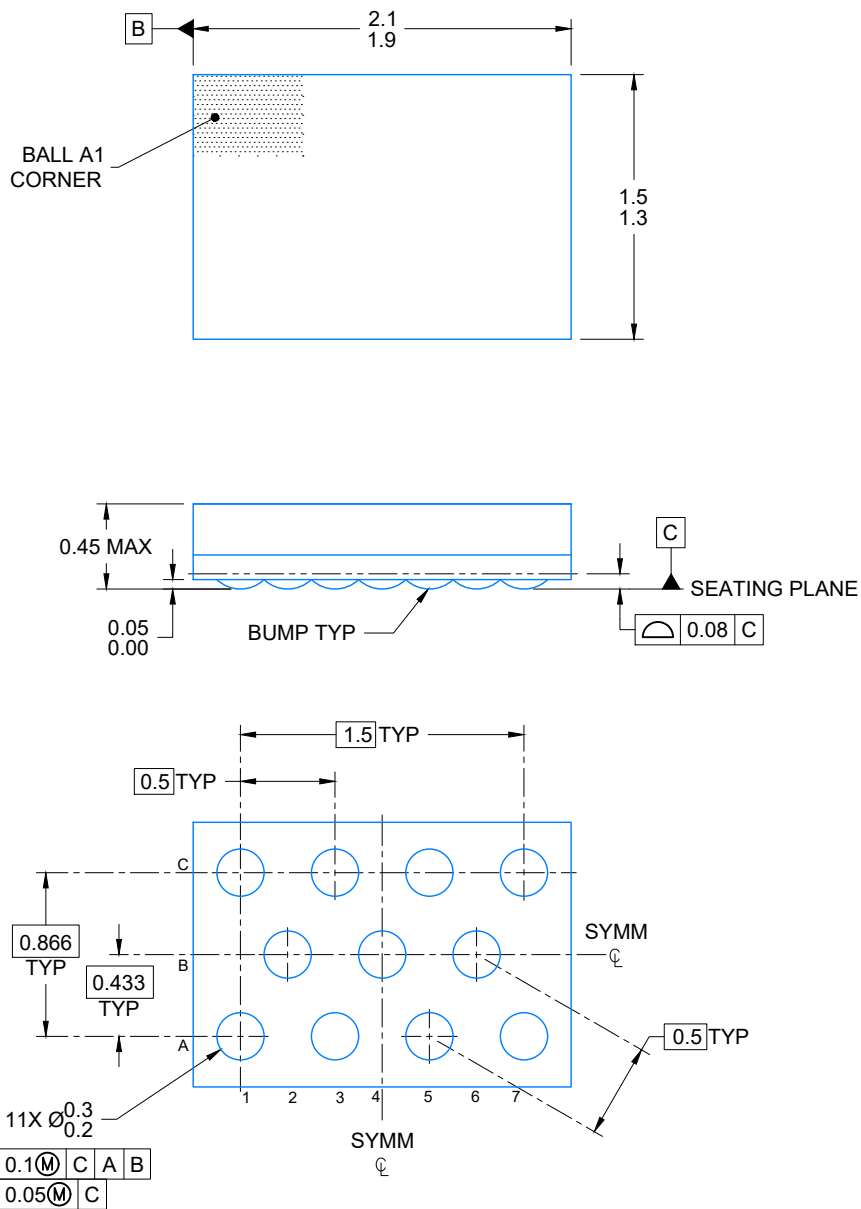
Device	Package Type	Package Drawing	Pins	SPQ	Length (mm)	Width (mm)	Height (mm)
SN74AVC4T234ZWAR	NFBGA	ZWA	11	2500	338.1	338.1	20.6



4224717/A 12/2018

NOTES:

NanoFree is a trademark of Texas Instruments.

1. All linear dimensions are in millimeters. Any dimensions in parenthesis are for reference only. Dimensioning and tolerancing per ASME Y14.5M.
2. This drawing is subject to change without notice.

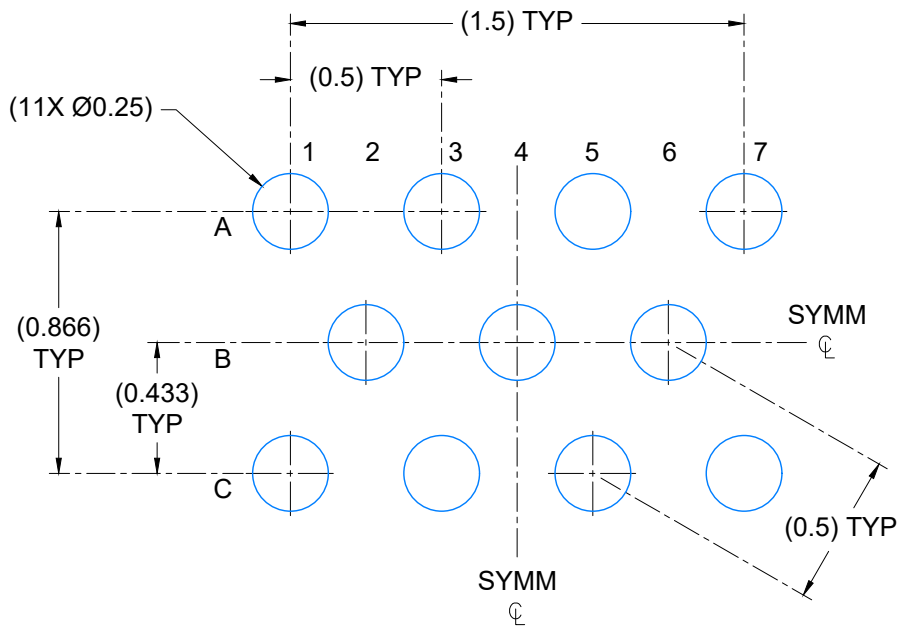

LAND PATTERN EXAMPLE
SCALE: 40X

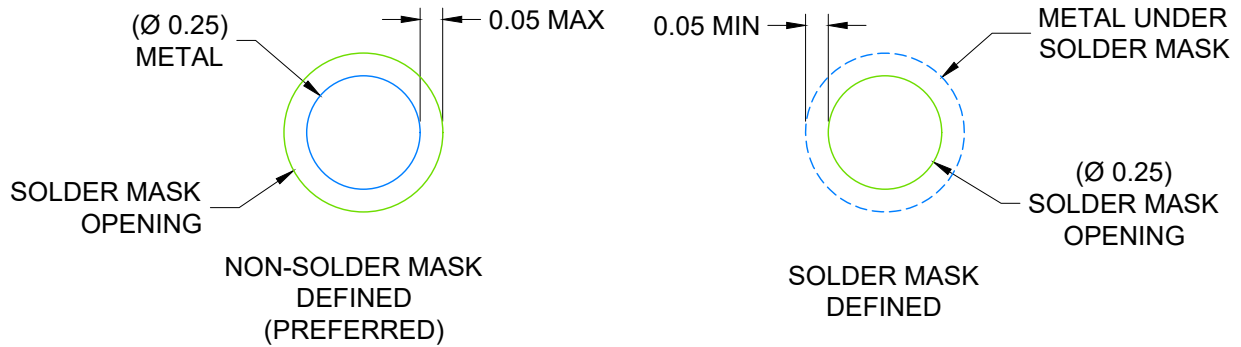

SOLDER MASK DETAILS
NOT TO SCALE

4224717/A 12/2018

NOTES: (continued)

- Final dimensions may vary due to manufacturing tolerance considerations and also routing constraints. Refer to Texas Instruments Literature number SNVA009 (www.ti.com/lit/snva009).

EXAMPLE STENCIL DESIGN

ZWA0011A

NFBGA - 0.45 mm max height

MICRO CHIP SCALE PACKAGE

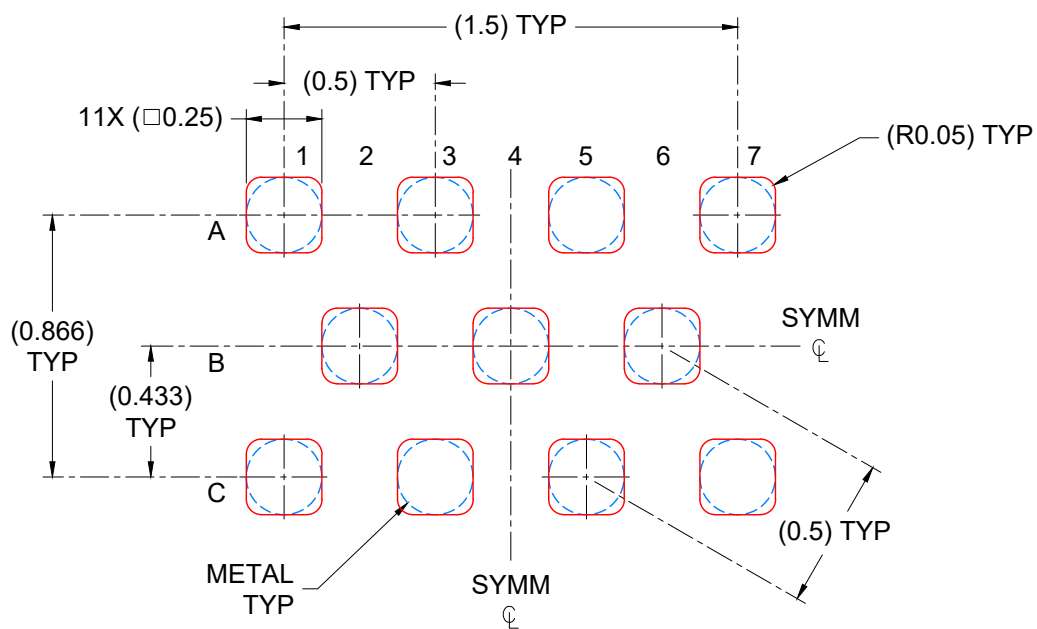

SOLDER PASTE EXAMPLE
BASED ON 0.1 mm THICK STENCIL
SCALE: 40X

4224717/A 12/2018

NOTES: (continued)

4. Laser cutting apertures with trapezoidal walls and rounded corners may offer better paste release.

IMPORTANT NOTICE AND DISCLAIMER

TI PROVIDES TECHNICAL AND RELIABILITY DATA (INCLUDING DATA SHEETS), DESIGN RESOURCES (INCLUDING REFERENCE DESIGNS), APPLICATION OR OTHER DESIGN ADVICE, WEB TOOLS, SAFETY INFORMATION, AND OTHER RESOURCES "AS IS" AND WITH ALL FAULTS, AND DISCLAIMS ALL WARRANTIES, EXPRESS AND IMPLIED, INCLUDING WITHOUT LIMITATION ANY IMPLIED WARRANTIES OF MERCHANTABILITY, FITNESS FOR A PARTICULAR PURPOSE OR NON-INFRINGEMENT OF THIRD PARTY INTELLECTUAL PROPERTY RIGHTS.

These resources are intended for skilled developers designing with TI products. You are solely responsible for (1) selecting the appropriate TI products for your application, (2) designing, validating and testing your application, and (3) ensuring your application meets applicable standards, and any other safety, security, regulatory or other requirements.

These resources are subject to change without notice. TI grants you permission to use these resources only for development of an application that uses the TI products described in the resource. Other reproduction and display of these resources is prohibited. No license is granted to any other TI intellectual property right or to any third party intellectual property right. TI disclaims responsibility for, and you will fully indemnify TI and its representatives against, any claims, damages, costs, losses, and liabilities arising out of your use of these resources.

TI's products are provided subject to [TI's Terms of Sale](#) or other applicable terms available either on ti.com or provided in conjunction with such TI products. TI's provision of these resources does not expand or otherwise alter TI's applicable warranties or warranty disclaimers for TI products.

TI objects to and rejects any additional or different terms you may have proposed.

Mailing Address: Texas Instruments, Post Office Box 655303, Dallas, Texas 75265
Copyright © 2021, Texas Instruments Incorporated