



Device Overview

The IDT 89HP0504PB (P0504PB) is a 5Gbps PCIe® Repeater device featuring IDT EyeBoost™ technology that compensates for cable and board trace attenuations and ISI jitter, thereby extending connection reach. The device is optimized for PCIe Gen1 and Gen2 high speed serial data streams and contains four data channels, each able to process 5Gbps transmission rates. Each channel consists of an input equalizer and amplifier, signal detection with glitch filter, as well as programmable output swing and de-emphasis. Allowing for application specific optimization, the P0504PB, with its configurable receiver and transmitter features, is ideal for PCIe applications using a wide combination of cables and board trace materials.

All modes of active data transfer are designed with minimized power consumption. In full shutdown mode, the part consumes less than 40mW in worst case environmental conditions.

Applications

- ◆ Blade servers, rack servers
- ◆ PCIe instrumentation
- ◆ Storage systems
- ◆ Cabled PCIe devices

Features

- ◆ Compensates for cable and PCB trace attenuation and ISI jitter
- ◆ Programmable receiver equalization up to 24db
- ◆ Programmable transmitter swing and de-emphasis
- ◆ Recovers data stream even when the differential signal eye is completely closed due to trace attenuation and ISI jitter
- ◆ Full PCIe protocol support
- ◆ Configurable via external pins
- ◆ Leading edge power minimization in active and shutdown modes
- ◆ No external bias resistors or reference clocks required
- ◆ Channel mux mode, demux mode, 1 to 2 channels multicast, and Z-switch function mode
- ◆ Available in a 36-pin QFN package (4.0 x 7.5mm with 0.5mm pitch)

Benefits

- ◆ Extends maximum cable length to over 8 meters and trace length over 48 inches in PCIe applications
- ◆ Minimizes BER

Typical Application

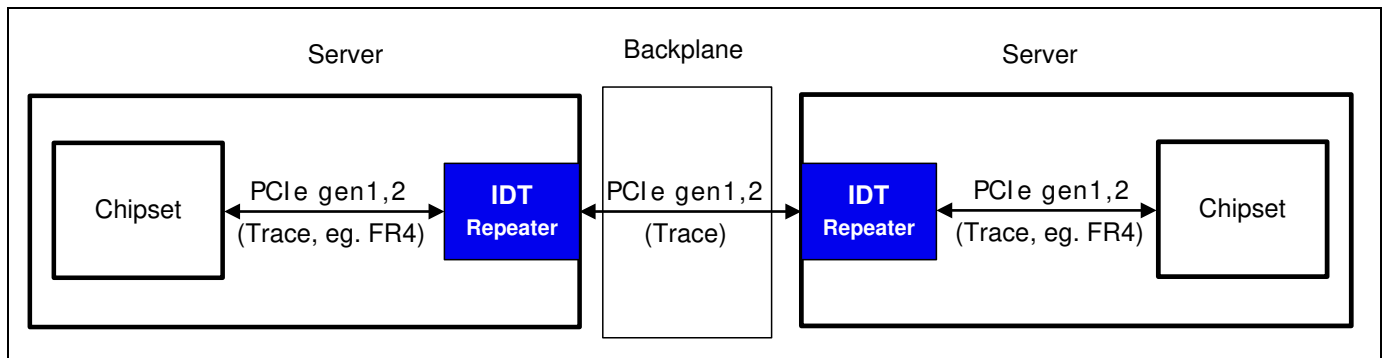

Figure 1 IDT Repeaters in Blade Servers

PCIe Compliance

The device was designed to provide end users with features needed to comply with PCIe system application requirements:

- Receiver Detection Support, PCIe Beacon Support
- Receiver supports high impedance mode for PCIe
- Jitter, eye opening, and all other key AC and DC specifications.

Block Diagram

The P0504PB contains four high speed channels as shown in Figure 2. Each channel can be routed to different outputs. Depending on user configuration via mode selections, input traffic can be muxed or demuxed. Powerdown (PDB) and Receiver Detection Reset (RSTB) are provided for state and channel control.

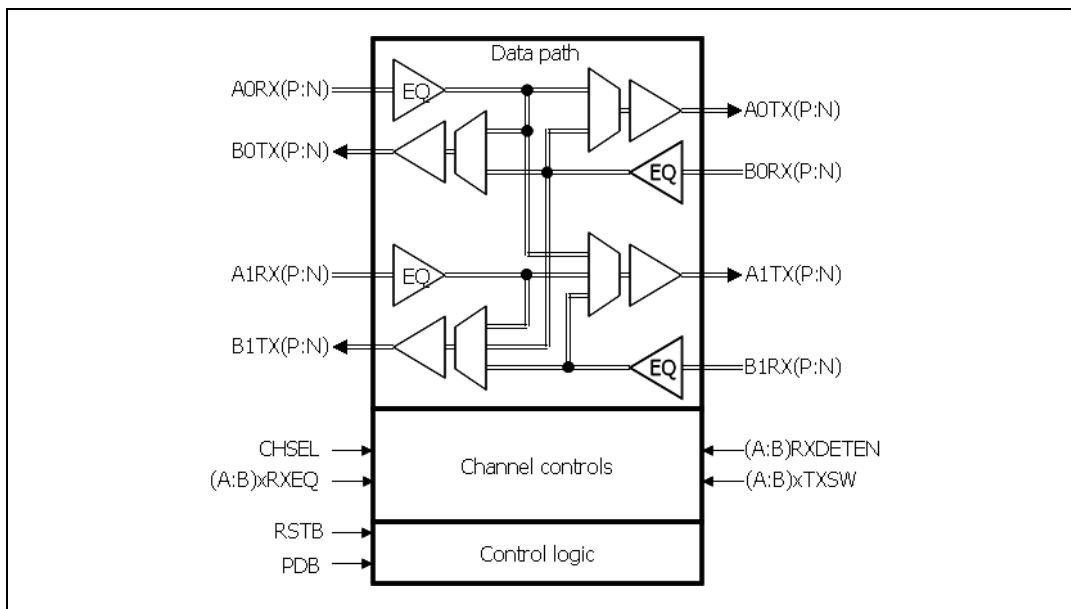

Figure 2 Block Diagram

Table of Contents

Device Overview	1
Applications.....	1
Features.....	1
Benefits.....	1
Typical Application	1
PCIe Compliance.....	2
Block Diagram.....	2
Functional Description	5
Power-Up.....	6
Power Sequencing.....	6
IDT EyeBoost™ Technology	6
Eye Diagram Parameters	7
Receiver Impedance.....	7
Transmitter Impedance.....	7
PCIe Receiver Detection Support.....	8
Modes of Operation	8
Channel Muxing.....	9
Electrical Specifications	13
Absolute Maximum Ratings	13
Recommended Operating Conditions.....	13
Power Consumption	14
Package Thermal Considerations.....	14
DC Specifications	15
AC Specifications.....	15
Pin Description.....	20
Package Pinout — 36-QFN Signal Pinout	22
Pin Diagram	23
QFN Package Dimension	24
Revision History	25
Ordering Information.....	26

PAGE INTENTIONALLY LEFT BLANK

Functional Description

The P0504PB has 4 channels, each with the individually programmable features listed below. Figure 3 diagrams the channel and Table 1 summarizes key configuration options.

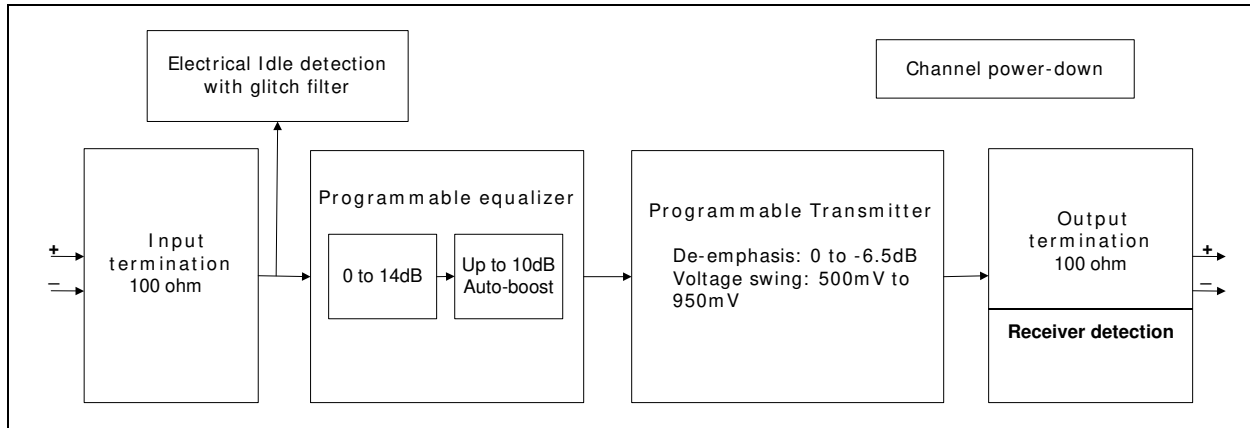

Figure 3 Channel Block Diagram with Channel Features

- ◆ Per-channel programmable features used at the Receive side.
 - Input equalization with 3 levels: 2 to 14dB compensation for high frequency signal attenuation due to cables and board traces. Additionally, up to 10dB boost is added automatically by the equalizer for applications using long cables. The total equalization range is between 2dB and 24dB.
 - Input high impedance control via channel enable: disabled (active mode) and hi-Z (power-down).
- ◆ Per-channel programmable features used at the Transmit side.
 - Output de-emphasis with 8 levels: 0 to -6.5dB. The de-emphasis boosts the magnitude of higher frequencies sent by the transmitter to compensate for high frequency losses travelling through output side cable or output side board traces. This ensures that the final received signal has a wider eye opening.
 - Output differential swing with 3 levels: 0.5V to 0.95V (peak-to-peak).
 - Receiver detection: enable or disable. This function is activated following an RSTB pulse.
 - With receiver detection enabled, if A0 and A1 channels do not detect at least one receiver, then the P0504PB on-chip Rx termination on A0 and A1 is set to hi-Z as shown in Table 2.
 - With receiver detection enabled, if B0 and B1 channels do not detect at least one receiver, then the P0504PB on-chip Rx termination on B0 and B1 is set to hi-Z as shown in Table 2.
 - Electrical idle detection: When the incoming differential peak-peak amplitude falls below 110mV, the device enters electrical idle mode and the corresponding transmitter stops toggling, maintains its common mode voltage level, and meets all electrical idle specifications described in the AC Specifications section of this data sheet.

In addition, the device contains global configuration of the data path:

- Transfer modes: direct connect, cross-connect, multicast.

Power-Up

After the power supplies reach their minimum required levels, the P0504PB powers up by setting all input and output pins to known states:

- ◆ All the device's input configuration pins are set internally to VSS or VDD for 2-level pins and to VDD/2 for 3-level pins.
- ◆ High speed differential input and output pins depend on various conditions described below:
 - High speed differential input and output pins are in high impedance if any of the following conditions is true:
 - Powerdown is set (PDB pin = 0V) or
 - No receiver termination was detected at TX outputs

In all other cases, high speed differential input and output pins are set to 50 ohms per pin, with 100 ohms differential impedance. Also refer to Table 4, Power Reducing Modes, Table 2, Receiver Impedance, and Table 3, Transmitter Impedance.

The power ramp up time for the P0504PB should be less than 1ms.

Power Sequencing

There are no power sequencing constraints for the P0504PB.

IDT EyeBoost™ Technology

IDT EyeBoost™ technology is a method of data stream recovery even when the differential signal eye is completely closed due to cable or trace attenuation and ISI jitter. With IDT EyeBoost™, the system designer can both recover the incoming data and retransmit it to target device with a maximized eye width and amplitude. An example of IDT EyeBoost™ technology usage in a system application and eye diagram results are shown in Figure 4. In this figure, the (a) diagram shows incoming differential signal (closed eye) after 62 inch FR4 connection from signal source and the (b) diagram shows differential signal at the output of repeater maximized eye opening with IDT EyeBoost™ technology.

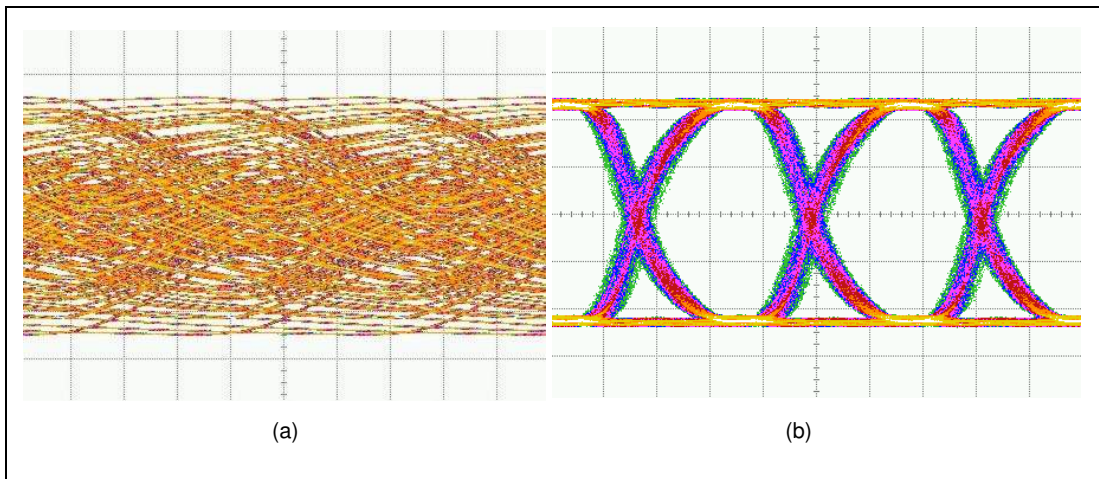

Figure 4 Eye Diagram

Eye Diagram Parameters

Feature	Feature Type	Parameter Names for Programming via Pins
Input equalization	Main eye optimization	A0RXEQ, A1RXEQ, B0RXEQ, B1RXEQ Range: 0dB to 14dB (plus additional auto-boost up to 10dB for long connections)
Output differential signal swing (peak-to-peak) and output de-emphasis	Main eye optimization	A0TXSW, A1TXSW, B0TXSW, B1TXSW Range: 0.5V to 0.95V for swing Range: 0 to -6.5dB for de-emphasis

Table 1 Quick Reference: Parameters Used for Eye Optimization

Receiver Impedance

The table below shows how the receiver impedance changes based on input and output pin states.

Mode	Control Inputs			Rx Terminations	Description
	PDB	[A,B]RXDETEN	RSTB		
Full IC Power-down	0	X	X	Hi-Z	Receiver terminations placed in Hi-Z.
Channel Enabled	1	0	1	50Ω	Receiver detect disabled. Receiver terminations set to 50Ω.
Channel Enabled	1	1	1	50Ω	Receiver detect enabled. Valid receiver detected. Receiver terminations set to 50Ω.

Table 2 Receiver Impedance

Transmitter Impedance

The table below shows how the transmitter impedance changes based on input and output pin states.

Mode	Control Inputs		Tx Terminations	Description
	[A,B]RXDETEN	RSTB		
Full IC Power-down	X	X	1kΩ	Receiver terminations placed in Hi-Z.
Channel Enabled	0	1	50Ω	Rx signal not detected. Receiver detect disabled. Receiver terminations set to Hi-Z.

Table 3 Transmitter Impedance (Part 1 of 2)

Mode	Control Inputs		Tx Terminations	Description
	[A,B]RXDETEN	RSTB		
Channel Enabled	0	1	50Ω	Rx signal detected. Receiver detect disabled. Receiver terminations set to 50Ω.
Channel Enabled but inactive	1	1	50Ω	TX output is squelched. A valid receiver was detected. Receiver terminations set to 50Ω. Output common-mode is held at its active value.
Channel Enabled and active	1	1	50Ω	TX output is active. A valid receiver was detected. Receiver terminations set to 50Ω.

Table 3 Transmitter Impedance (Part 2 of 2)

PCIe Receiver Detection Support

The P0504PB transmitter fully supports PCIe Receiver Detection requirements. Receiver detection is enabled for channels A0 and A1 by asserting pin ARXDETEN and for channels B0 and B1 by asserting pin BRXDETEN. For receiver detection to occur, a low pulse (minimum 200ns) must be applied at pin RSTB. The rising edge of the RSTB signal starts the receiver detection procedure. Neither ARXDETEN nor BRXDETEN can be toggled during the receiver detection procedure, i.e., they must be kept high for at least 200ns before the RSTB rising edge and they cannot go to low sooner than 2ms from the time the RSTB goes high. The receiver detection takes place once per RSTB pulse.

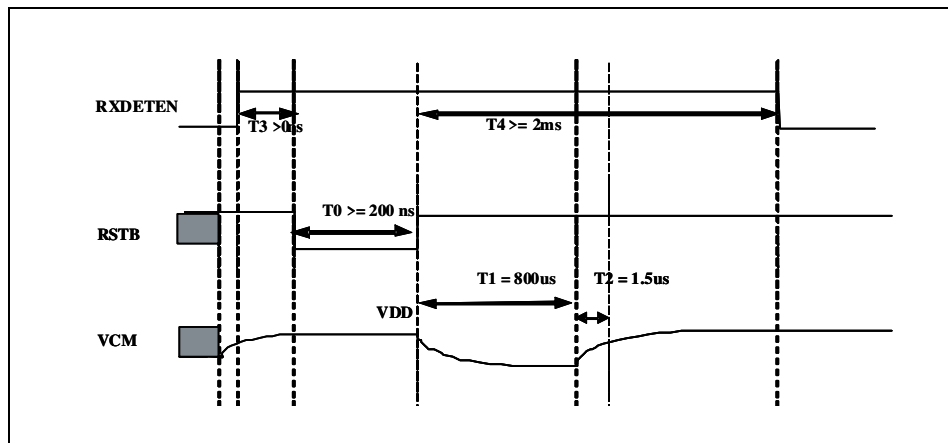

Figure 5 Receiver Detection Timing

Modes of Operation

The device supports several data transfer modes, electrical idle mode, and several power reducing modes.

Electrical Idle Mode

In electrical idle mode, the transmitter stops toggling and maintains its common-mode voltage level. The device enters electrical idle mode when the envelope of the incoming signal on a given channel has fallen below a programmable threshold level.

Power Reducing Modes

The Repeater supports five power-down states and one active state as shown in Table 4. The user can choose between full chip power-down, channel based power-down, and electrical idle modes. Power reducing modes can be selected via PDB and RSTB.

Power Reducing Mode	Required Signal Values		State Description
	Power-Down Control	Receiver Detect Start	
	PDB	RSTB	
Full IC power-down	0	X	All channels are powered-down Receiver detect reset Rx termination is set to Hi-Z Tx termination is set to 1k Ω Tx common-mode is at VDD
Receiver Detect reset	1	0	Receiver detect state machine Receiver terminations placed in Hi-Z Tx termination is set to 1k Ω Tx common-mode is at VDD
Channel enabled but inactive (electrical idle). Rx and Tx set to hi-Z	1	1	Tx output is squelched No receiver was Detected Receiver terminations placed in Hi-Z Tx termination is set to 1k Ω Tx common-mode is at VDD
Channel enabled but inactive (electrical idle). Rx and Tx set to 50 Ohms	1	1	Tx output is squelched A valid receiver was detected Receiver terminations set to 50 Ω Output common-mode is held at its active value Tx termination is set to 50 Ω
Channel enabled and active. No power-down	1	1	Tx output is active A valid receiver was detected Receiver terminations set to 50 Ω Transmitter terminations set to 50 Ω

Table 4 Power Reducing Modes

Channel Muxing

The P0504PB repeater permits a variety of muxing, demuxing, and switching configurations, and it can mux/de-mux 1 or 2 bi-directional PCIe lanes (4 PCIe channels) into 2 target devices. These configurations require the selection of specific pins for input and output ports. In the following sections, each configuration is described in terms of pin connectivity to external upstream and downstream devices. The configurations shown are those often used in system designs:

- Uni-directional 2:1 Mux (1 or 2 instances)
- Uni-directional 1:2 De-Mux (1 or 2 instances)
- Bi-directional 2:1 Mux/De-Mux
- Bi-directional Z-function (also called Partial Cross Function)

The P0504PB supports channel muxing in both upstream and downstream channel directions via the CHSEL pin, as shown below. Figure 6 shows the channel/reference muxing modes and Table 5 shows how CHSEL (Channel transfer selection) pin allows for various modes of data transfers: Multicast mode, Direct-connect, and Cross-connect. Both Direct-connect, and Cross-connect modes are used to build uni-directional and bi-directional 2:1 mux and Z-switch functions.

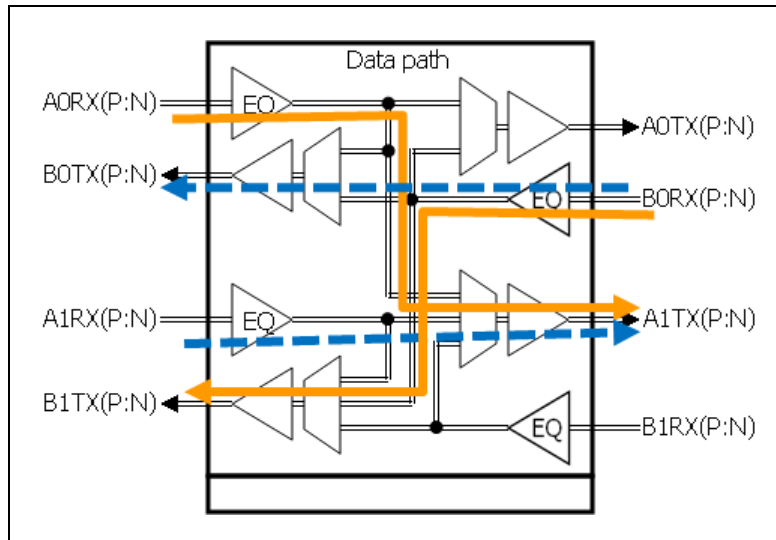

Figure 6 Diagram of Channel/Reference Muxing Modes

Input Pins					Output Pins			
CHSEL	A0RX[P,N]	A1RX[P,N]	B0RX[P,N]	B1RX[P,N]	A0TX[P,N]	A1TX[P,N]	B0TX[P,N]	B1TX[P,N]
CHSEL=VSS (Multicast Mode)	A0 DATA	X	B0 DATA	X	A0 DATA	A0 DATA	B0 DATA	B0 DATA
CHSEL=Open (Direct-Connect Mode)	A0 DATA	A1 DATA	B0 DATA	B1 DATA	A0 DATA	A1 DATA	B0 DATA	B1 DATA
CHSEL=VDD (Cross-Connect Mode)	A0 DATA	X	B0 DATA	X	Squelched	A0 DATA	Squelched	B0 DATA

Table 5 Description of Channel Muxing/De-Muxing Functionality

Uni-directional 2:1 Mux or Two Instances of Unidirectional 2:1 Mux

This function can be achieved by using the CHSEL pin as a mux control signal. CHSEL should be set to either VDD or OPEN. The ports should be configured as shown in Figure 7.

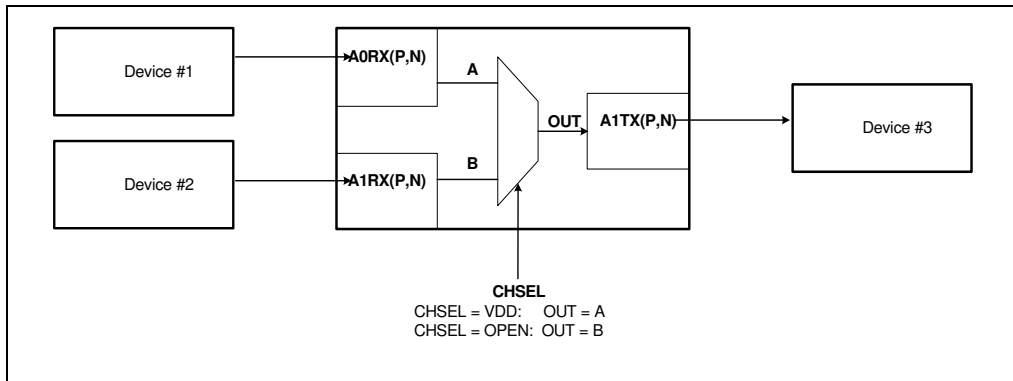

Figure 7 Implementation of Unidirectional 2:1 Mux

As an alternative, different chip channels can also be selected as shown in Figure 8. This solution can be combined with the previous one to obtain two instances of Uni-directional 2:1 Mux.

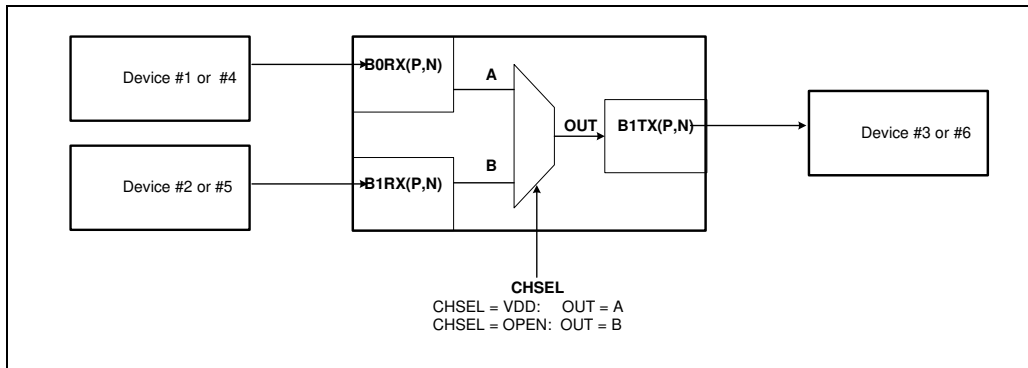

Figure 8 Implementation of Second Instance of Unidirectional 2:1 Mux

Uni-directional 1:2 De-Mux or Two Instances of Unidirectional 1:2 De-Mux

This function can be achieved by using CHSEL pin as a de-mux control signal. CHSEL should be set to either VDD or OPEN. The ports should be configured as shown in Figure 9.

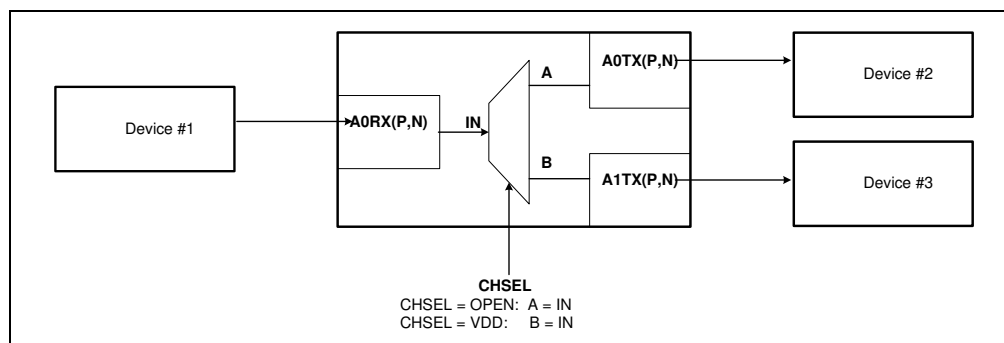

Figure 9 Implementation of Unidirectional 1:2 De-Mux

As an alternative, different chip channels can also be selected as shown in Figure 10. This solution can be combined with the previous one to obtain two instances of Uni-directional 1:2 De-Mux.

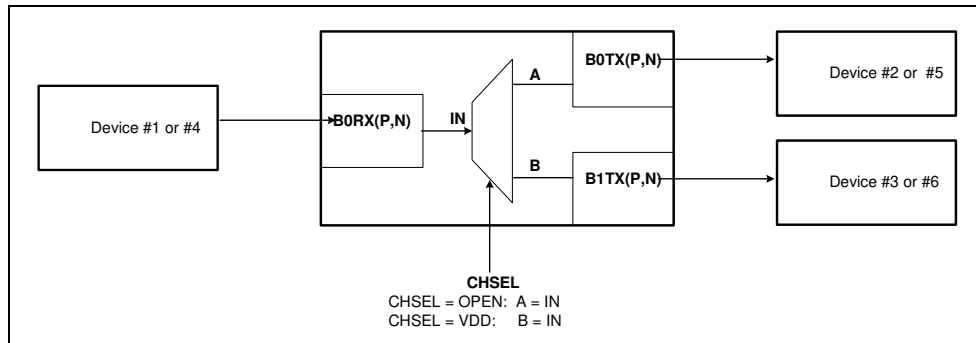

Figure 10 Implementation of Second Instance of Unidirectional 1:2 De-Mux

Bi-directional 2:1 Mux/De-Mux

The bi-directional Mux and De-Mux function can also be achieved by using the CHSEL pin as a mux control signal. CHSEL should be set to either VDD or OPEN. The ports should be configured as shown in Figure 11.

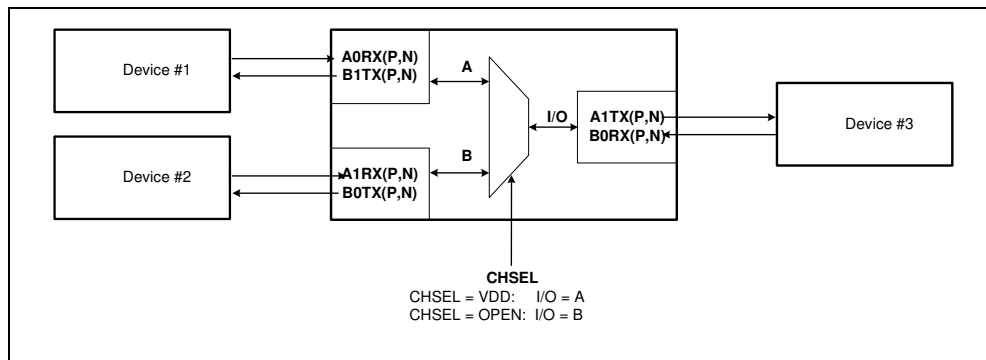

Figure 11 Implementation of Bi-directional 2:1 Mux/De-Mux

Bi-directional Z-function (also called Partial Cross Function)

This function can also be achieved by using the CHSEL pin as a flow control signal. CHSEL should be set to either VDD or OPEN. The ports should be configured as shown in Figure 12.

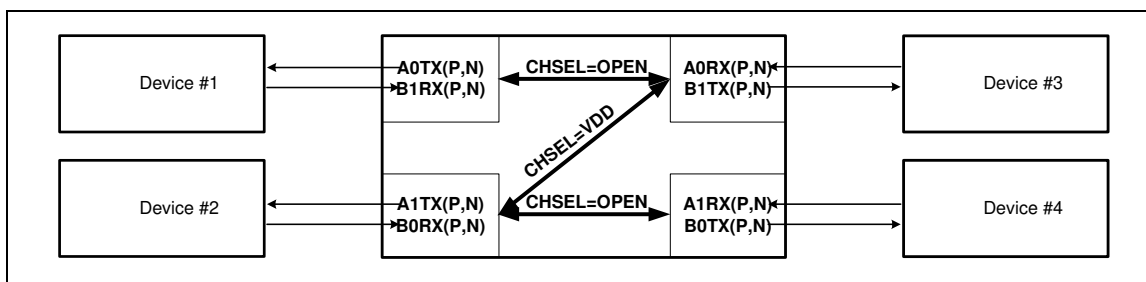

Figure 12 Implementation of Z-function

Electrical Specifications

Absolute Maximum Ratings

Note: All voltage values, except differential voltages, are measured with respect to ground pins.

Parameter	Value	Unit
Supply voltage range VDD	-0.5 to 1.35	V
Voltage range Differential I/O	-0.5 to VDD +0.5	V
Control I/O	-0.5 to VDD + 0.5	V
ESD requirements: Electrostatic discharge Human body model	±2000	V
ESD requirements: Charged-Device Model (CDM)	±500	V
ESD requirements: Machine model	±125	V
Storage ambient temperature	-55 to 150	°C

Table 6 Absolute Maximum Ratings

Warning: Stresses beyond those listed under absolute maximum ratings may cause permanent damage to the device. These are stress ratings only and functional operation of the device at these or any conditions beyond those indicated under Recommended Operating Conditions is not implied. Exposure to absolute-maximum-rated conditions for extended periods may affect device reliability.

Recommended Operating Conditions

Parameter	Notes	Min	Typical	Max	Unit
Power Supply Pin Requirements					
VDD	1.2V DC analog supply voltage (specified at bump pins)	1.14	1.2	1.26	V
Temperature Requirements					
TA	Ambient operating temperature - Commercial	0	—	70	°C
	Ambient operating temperature - Industrial	-40	—	85	°C
TJUNCTION	Junction operating temperature	0	—	125	°C

Table 7 Operating Conditions

Power Consumption

Table 8 below lists power consumption values under typical and maximum operating conditions.

Parameter	Notes	Min	Typical	Max	Unit
Active Mode					
I_{VDD}	Current into VDD supply	—	330	500	mA
P_D	Full chip power ¹		400	600	mW
P_{D-ch}	Power per channel ¹		100	150	mW
Standby Mode			30	40	mW

Table 8 Power Consumption

¹ Maximum power under all conditions. Power is reduced by selecting smaller de-emphasis settings (closer or equal to 0dB).

Package Thermal Considerations

The data in Table 9 below contains information that is relevant to the thermal performance of the 36-pin QFN package.

Parameter	Description	Value	Conditions	Units
$T_{J(max)}$	Junction Temperature	125	Maximum	°C
$T_{A(max)}$	Ambient Temperature	70	Maximum for commercial-rated products	°C
		85	Maximum for industrial-rated products	°C
$\theta_{JA(effective)}$	Effective Thermal Resistance, Junction-to-Ambient	41.8	Zero air flow	°C/W
		36.1	1 m/S air flow	°C/W
		35.3	2 m/S air flow	°C/W
		34.3	3 m/S air flow	°C/W
		33.7	4 m/S air flow	°C/W
		33.2	5 m/S air flow	°C/W
θ_{JB}	Thermal Resistance, Junction-to-Board	14.5	NA	°C/W
θ_{JC}	Thermal Resistance, Junction-to-Case	37.2	NA	°C/W

Table 9 Thermal Specifications for P0504PB, 4.0x7.5mm 36-QFN Package

Note: It is important for the reliability of this device in any user environment that the junction temperature not exceed the $T_{J(max)}$ value specified in Table 9. Consequently, the effective junction to ambient thermal resistance (θ_{JA}) for the worst case scenario must be maintained below the value determined by the formula:

$$\theta_{JA} = (T_{J(max)} - T_{A(max)})/P$$

Given that the values of $T_{J(max)}$, $T_{A(max)}$, and P are known, the value of desired θ_{JA} becomes a known entity to the system designer. How to achieve the desired θ_{JA} is left up to the board or system designer, but in general, it can be achieved by adding the effects of θ_{JC} (value provided in Table 9), thermal resistance of the chosen adhesive (θ_{CS}), that of the heat sink (θ_{SA}), amount of airflow, and properties of the circuit board (number of layers and size of the board).

DC Specifications

Parameter	Description	Min	Typ	Max	Unit
V _{IL}	Digital Input Signal Voltage Low Level ¹	-0.3	—	0.25*VDD-0.1	V
V _{IM}	Digital Input Signal Voltage Mid Level ²	0.25*VDD+ 0.1		0.75*VDD-0.1	V
V _{IH}	Digital Input Signal Voltage High Level ¹	0.75*VDD+ 0.1		VDD+ 0.3	V
V _{HYS}	Hysteresis of Schmitt Trigger Input	0.1		—	V
I _{IL}	Input Current ³	—		100	μA
I _{IH}	Input Current ⁴	—		100	μA
I _{IL1}	Input Current ²	—		180	μA
I _{IH1}	Input Current ²	—		180	μA
R _{WEAK_PD_2L}	Internal weak pull-down resistor at 2-level input pads ⁴	11		—	K ohm
R _{WEAK_PU_2L}	Internal weak pull-up resistor at 2-level input pads ³	11		—	K ohm
R _{WEAK_PD_3L}	Internal weak pull-down resistor at all 3-level input pads	6.3		—	K ohm
R _{WEAK_PU_3L}	Internal weak pull-up resistor at all 3-level input pads	6.3		—	K ohm

Table 10 DC Specification

¹ Applies to all input pins.

² Applies to all 3-level input pins.

³ Applies only to 2-level input pins with default values set to VDD in the Pin Description table (Table 14).

⁴ Applies only to 2-level input pins with default values set to VSS in the Pin Description table (Table 14).

AC Specifications

Latency Specification

Parameter	Description	Min	Typical	Max	Unit
Latency	Input to output signal propagation device	—	300	—	ps

Table 11 Latency Specification

Receiver Specifications

Parameter	Description	Min	Typical	Max	Unit
Receiver Input Jitter Specifications					
T _{RX-DDJ}	Receive Input Signal Data Dependent Jitter (Inter-Symbol Interference).	—	—	>1	UI
T _{RX-TJ}	Receive Input Signal Total Jitter	—	—	>1	UI
T _{RX-EYE}	Receiver eye time opening (can recover from closed eye due to trace attenuation and ISI jitter)	0	—	—	UI
Receiver Input Eye Specification					
V _{RX-DIFF-PP-DC}	Receiver Differential Peak-Peak Voltage ¹	0	—	2000	mV
V _{RX-CM-DC}	Receiver DC Common Mode Voltage	—	0	—	mV
V _{RX-CM-AC-P}	Receiver AC Common Mode Voltage	—	—	150	mV
Receiver Return Loss					
RL _{RX-DIFF-F1}	Receiver Differential Return Loss (0 - 1.25GHz)	—	—	-10	dB
RL _{RX-DIFF-F2}	Receiver Differential Return Loss (1.25 - 2.5GHz)	—	—	-8	dB
RL _{RX-CM}	Receiver Common-Mode DC Return Loss	—	—	-6	dB
Receiver DC Impedance					
Z _{RX-DC}	Receive Impedance (singled-ended)	40	50	60	Ohm
Z _{RX-DIFF-DC}	DC differential impedance	80	100	120	Ohm
Z _{RX-HIGH-IMP-DC-POS}	DC Input Common-Mode Receive High Impedance for Input Voltage from 0V to 200mV	50k	—	—	Ohm
Z _{RX-HIGH-IMP-DC-NEG}	DC Input Common-Mode Receive High Impedance for Input Voltage from 0V to -200mV	1k	—	—	Ohm
Z _{DIFF-HIZ-POS}	Differential Receive High Impedance for Input Voltage from 0V to 200mV	200k	—	—	Ohm
Z _{DIFF-HIZ-NEG}	Differential Receive High Impedance for Input Voltage from 0V to -200mV	4k	—	—	Ohm
Receiver Signal Detection					
V _{RX-IDLE-DET-DIFFp-p}	Electrical Idle Signal Detect Threshold	70	110	150	mV
T _{RX-IDLE-DET-DIFF-ENTER-TIME}	Unexpected Electrical Idle Enter Detect Threshold Integration Time	—	—	10	ms
T _{SIGDET-ATTACK}	Signal Detect Valid Signal Attack Time (Turn-on time)	—	—	15	ns
T _{SIGDET-DECAY}	Signal Detect Valid Signal Decay Time (Turn-off time)	—	—	15	ns
T _{SIGDET-ATT-DECAY-MIS}	Signal Detect Attack / Decay Time Mismatch	—	—	5	ns

Table 12 Receiver Electrical Specifications

¹: The minimum value of 0 mV represents the case when Eye is completely closed.

Transmitter Specifications

Parameter	Description	Min	Typical	Max	Unit
Output Eye and Common Voltage Specification					
V _{TX-DIFF-PP}	Differential Transmitter swing [A:B]xTXSW=1 [A:B]xTXSW=open	800 700	950 800	1100 950	mV
V _{TX-DIFF-PP-LOW}	Low power differential p-p Transmitter swing [A:B]xTXSW=0	400	500	650	mV
D _{TX-DEEMP}	Output De-emphasis. Defined as 20log(V _{TX-DE-EMP} / V _{TX-DIFF}) [dB]	-6.5	—	0	dB
V _{TX-DE-RATIO-3.5dB}	Tx de-emphasis level ratio [A:B]xTXSW=open	-4.0	—	-3.0	dB
V _{TX-DE-RATIO-6dB}	Tx de-emphasis level [A:B]xTXSW=1	-6.5	—	-5.5	dB
T _{TX-RISE-FALL}	Rise/Fall Time	0.125	—	—	UI
T _{RF-MISMATCH}	Tx rise/fall mismatch	—	—	0.1	UI
T _{RES-DJ-5GBPS-1}	Residual Deterministic Jitter at output pins (1 inch FR4 trace before receiver input pins, 5Gbps) ¹	—	—	<0.1	UI
T _{RES-DJ-5GBPS-2}	Residual Deterministic Jitter at output pins (40 inch FR4 trace before receiver input pins, 5Gbps) ¹	—	0.15	0.2	UI
V _{TX-CM-AC-PP}	Pk-Pk AC Common Mode Voltage Variation	—	—	50	mV
V _{TX-CM-AC-P}	Tx AC common mode voltage (2.5 GT/s)	—	—	20	mV
V _{TX-CM-RMS-AC}	RMS AC Common Mode Voltage Variation	—	—	20	mV
V _{TX-DC-CM}	Transmitter DC common-mode voltage	0	—	VDD	V
V _{TX-CM-DC-LINEDELTA}	Absolute Delta of DC Common Mode Voltage between P and N	0	—	25	mV
C _{TX}	AC Coupling Capacitor	75	—	200	nF
Transmitter DC Impedance					
Z _{TX-DIFF-DC}	Transmitter Output Differential DC Impedance ²	80	100	120	Ohm
I _{TX-SHORT}	Transmitter short-circuit current limit	—	—	90	mA
Transmitter Return Loss					
RL _{TX-DIFF-F1}	Transmitter Differential Return Loss (0 - 1.25GHz)	—	—	-10	dB
RL _{TX-DIFF-F2}	Transmitter Differential Return Loss (1.25 - 2.5GHz)	—	—	-8	dB
RL _{TX-CM}	Transmitter Common-Mode DC Return Loss	—	—	-6	dB
Electrical Idle					
V _{TX-IDLE}	Idle Output Voltage	—	—	20	mV
V _{CM-DELTA-SQUELCH}	Maximum Common-Mode Step Entering/Exiting Electrical Idle Mode	—	—	50	mV

Table 13 Transmitter Electrical Requirements (Part 1 of 2)

Parameter	Description	Min	Typical	Max	Unit
$V_{TX-CM-DC-ACTIVEIDLE-DELTA}$	Absolute Delta of DC Common Mode Voltage during L0 and Electrical Idle.	0	—	100	mV
$V_{TX-IDLE-DIFF-AC-p}$	Electrical Idle Differential Peak Output Voltage	0	—	20	mV
$V_{TX-IDLE-DIFF-DC}$	DC Electrical Idle Differential Output Voltage	0	—	5	mV
Lane Skew					
$L_{TX-SKEW}$	Lane-to-Lane Output Skew	—	5	10	ps
Receiver Detect					
$V_{TX-RCV-DETECT}$	Voltage change allowed during receiver detection	—	—	600	mV
T0	RSTB negative pulse width	200	—	—	ns
T1	VCM pulsing (ramp up)	—	800	—	μs
T2	VCM pulsing (ramp down)	—	1.5	—	μs
T3	Time from RXDETEN high to RSTB pulse	0	—	—	ns

Table 13 Transmitter Electrical Requirements (Part 2 of 2)

¹ Refer to Figure 13.

² When TERM_CTL bit is set to 100 Ω .

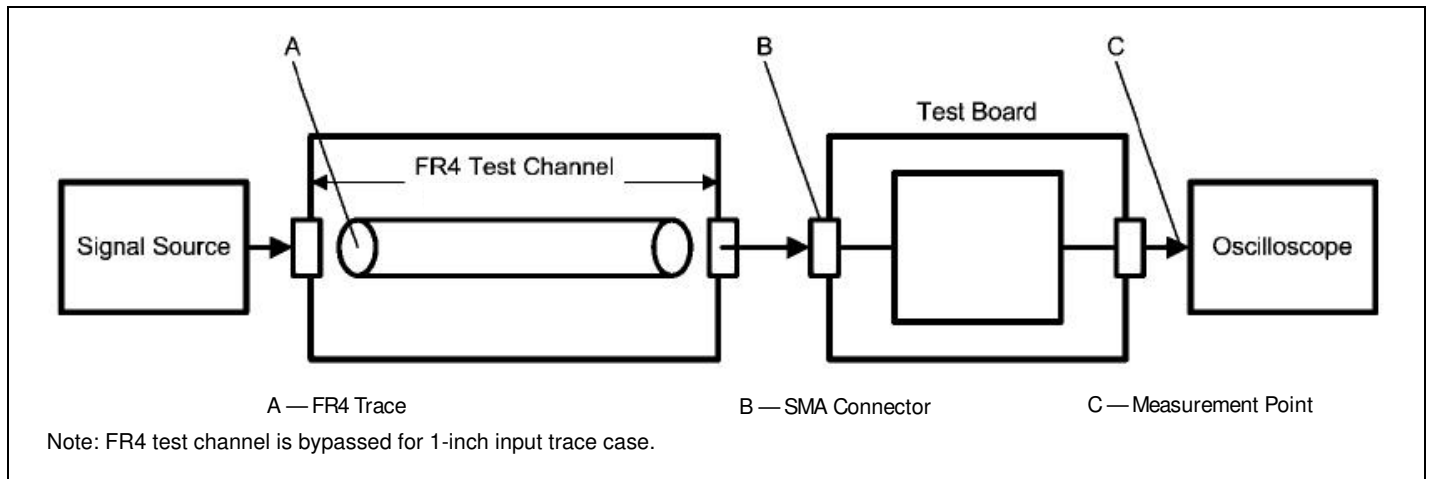

Figure 13 Residual Jitter Characterization Test Setup

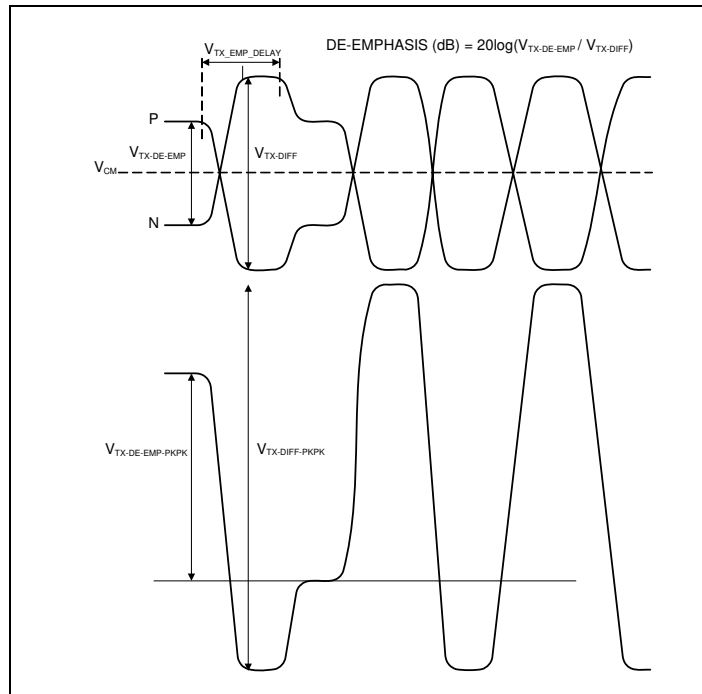

Figure 14 Transmitter Swing Levels With and Without De-emphasis

Note: $V_{TX-DIFF-PKPK}$ Peak to Peak voltage is twice as large as voltage difference between P pins and N pins of differential pairs. For example, if the P pin swings from 0.8V to 1.4V while the N pin swings from 1.4V to 0.8V, then: $V_{TX-DIFF-PKPK} = 2*(1.4-0.8)=1.2V$.

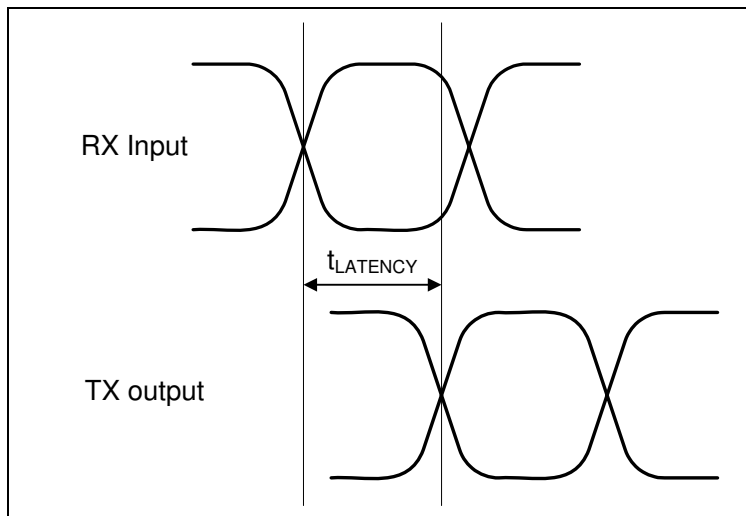

Figure 15 Definition of Latency Timing

Pin Description

Note: Unused pins can be left floating.

Pin Name	Pin #	Description	Input/ Output/ Power 2 or 3 Level
Power			
VDD	5, 8, 11, 21, 24, 27	1.2V (typ) Power supply for Repeater high speed channels and internal logic. Each VDD pin should be connected to the VDD plane through a low inductance path, with a via located as close as possible to the landing pad of VDD pins. It is recommended to have a 0.01 μ F or 0.1 μ F, X7R, size-0402 bypass capacitor from each VDD pin to ground plane.	Power
VSS	Center Pad	VSS reference. VSS should be connected to the ground plane through a low inductance path, with a via located as close as possible to the landing pad.	Power
Data Signals			
A0RXN A0RXP	4 3	Channel A0 Receive Data Ports	Input
A0TXN A0TXP	28 29	Channel A0 Transmit Data Ports	Output
B0RXN B0RXP	25 26	Channel B0 Receive Data Ports	Input
B0TXN B0TXP	7 6	Channel B0 Transmit Data Ports	Output
A1RXN A1RXP	10 9	Channel A1 Receive Data Ports	Input
A1TXN A1TXP	22 23	Channel A1 Transmit Data Ports	Output
B1RXN B1RXP	19 20	Channel B1 Receive Data Ports	Input
B1TXN B1TXP	13 12	Channel B1 Transmit Data Ports	Output
Channel Control and Status			
A0RXEQ (Channel A0) B0RXEQ (Channel B0) A1RXEQ (Channel A1) B1RXEQ (Channel B1)	15 17 36 33	Receiver Equalization. Programming of channel A0 via pins is shown below. To program other channels, use pins for those channels. <u>A0RXEQ</u> <u>Setting</u> VSS 2dB Open 6dB (Default) VDD 14dB	Input - 3 level

Table 14 Pin Description (Part 1 of 2)

Pin Name	Pin #	Description	Input/Output/Power 2 or 3 Level
A0TXSW (Channel A0) B0TXSW (Channel B0) A1TXSW (Channel A1) B1TXSW (Channel B1)	1 32 14 18	Transmitter Voltage Swing (pk-pk). Programming of channel A0 via pins is shown below. To program other channels, use pins for those channels. <u>A0TXSW</u> <u>Swing</u> <u>De-Emphasis</u> VSS 0.5Vdiff-pkpk 0dB Open 0.8Vdiff-pkpk (Default) -3.5dB VDD 0.95Vdiff-pkpk -6.5dB	Input - 3 level
Other Control Signals			
PDB	35	Power-down Enable. <u>PDB</u> <u>Setting</u> VSS Powerdown IC. RX terminations are in Hi-Z, TX is disabled VDD Normal operation (internal 11K ohm minimum pull-up applied)	Input - 2 level
RSTB	34	Receiver Detection Start. <u>RSTB</u> <u>Setting</u> VSS Resets Channel Receiver Detection State Machine VDD Normal operation (internal 11K ohm minimum pull-up applied) Note: the rising edge of RSTB will start the receiver detection.	Input - 2 level
ARXDETEN BRXDETEN	16 31	Output Channel Receiver Detect Enable Input. Programming of channel ARXDETEN via pins is shown below. To program BRXDETEN, use pins for that channel. <u>ARXDETEN</u> <u>Setting</u> VSS Receiver Detection is disabled for A0 and A1 channels (internal 11K ohm minimum pull-down applied) VDD Receiver Detection is enabled for A0 and A1 channels	Input - 2 level
CHSEL	30	Channel Transfer Mode. <u>CHSEL</u> <u>Setting</u> VSS Multi-cast mode Open Direct-connect mode (default) VDD Cross-connect mode	Input - 3 level
RSVD	2	Reserved. Do not connect.	

Table 14 Pin Description (Part 2 of 2)

Package Pinout — 36-QFN Signal Pinout

Table 15 lists the pin numbers and signal names for the P0504PB device.

Function	Pin	Function	Pin	Function	Pin
A0RXEQ	15	ARXDETEN	16	B1TXSW	18
A0RXN	4	B0RXEQ	17	BRXDETEN	31
A0RXP	3	B0RXN	25	CHSEL	30
A0TXN	28	B0RXP	26	PDB	35
A0TXP	29	B0TXN	7	RSTB	34
A0TXSW	1	B0TXP	6	RSVD	2
A1RXEQ	36	B0TXSW	32	VDD	5
A1RXN	10	B1RXEQ	33	VDD	8
A1RXP	9	B1RXN	19	VDD	11
A1TXN	22	B1RXP	20	VDD	21
A1TXP	23	B1TXN	13	VDD	24
A1TXSW	14	B1TXP	12	VDD	27

Table 15 Alphabetical Pin List

Pin Diagram

The following figure lists the pin numbers and the signal names for the 36-QFN package.

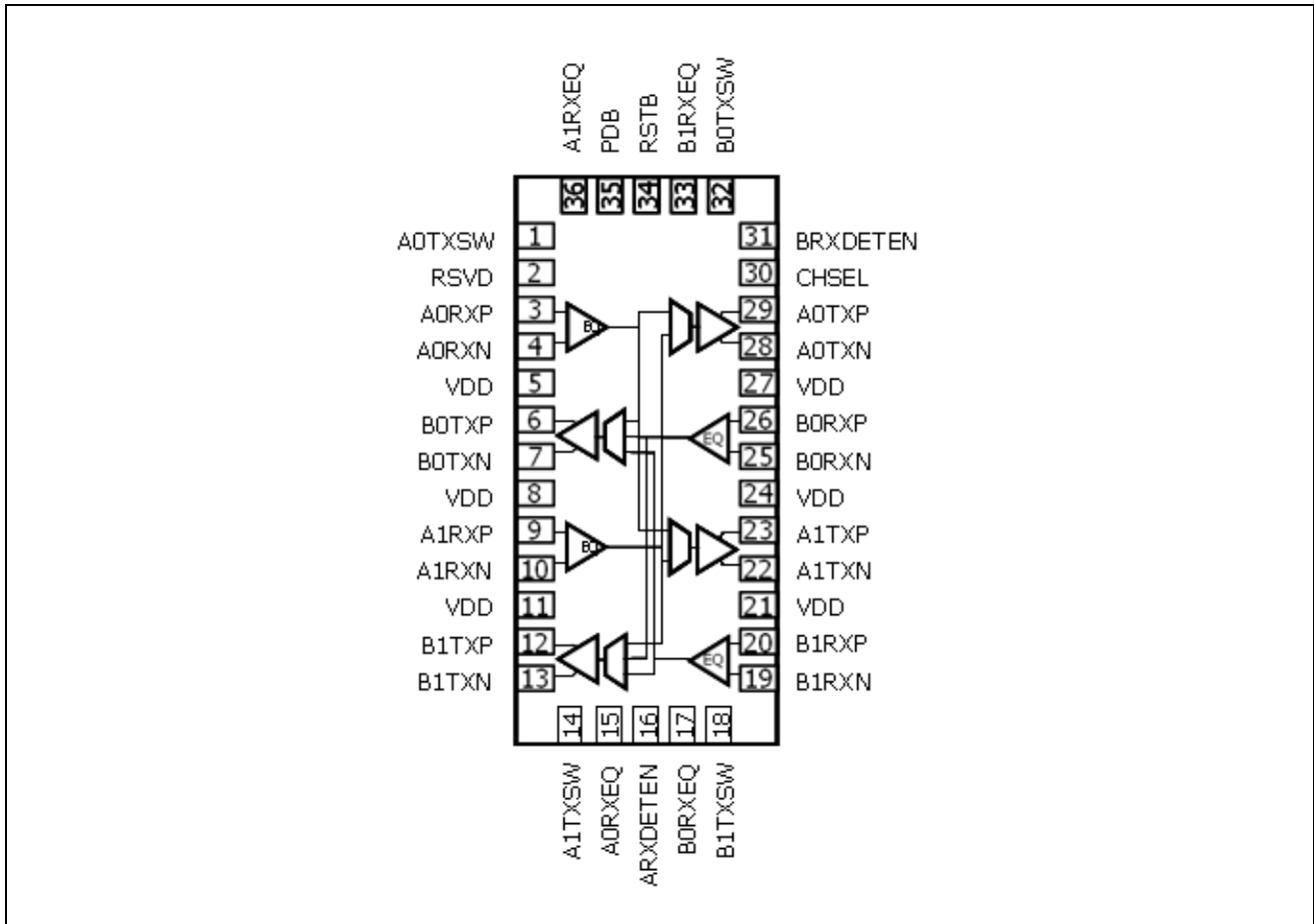
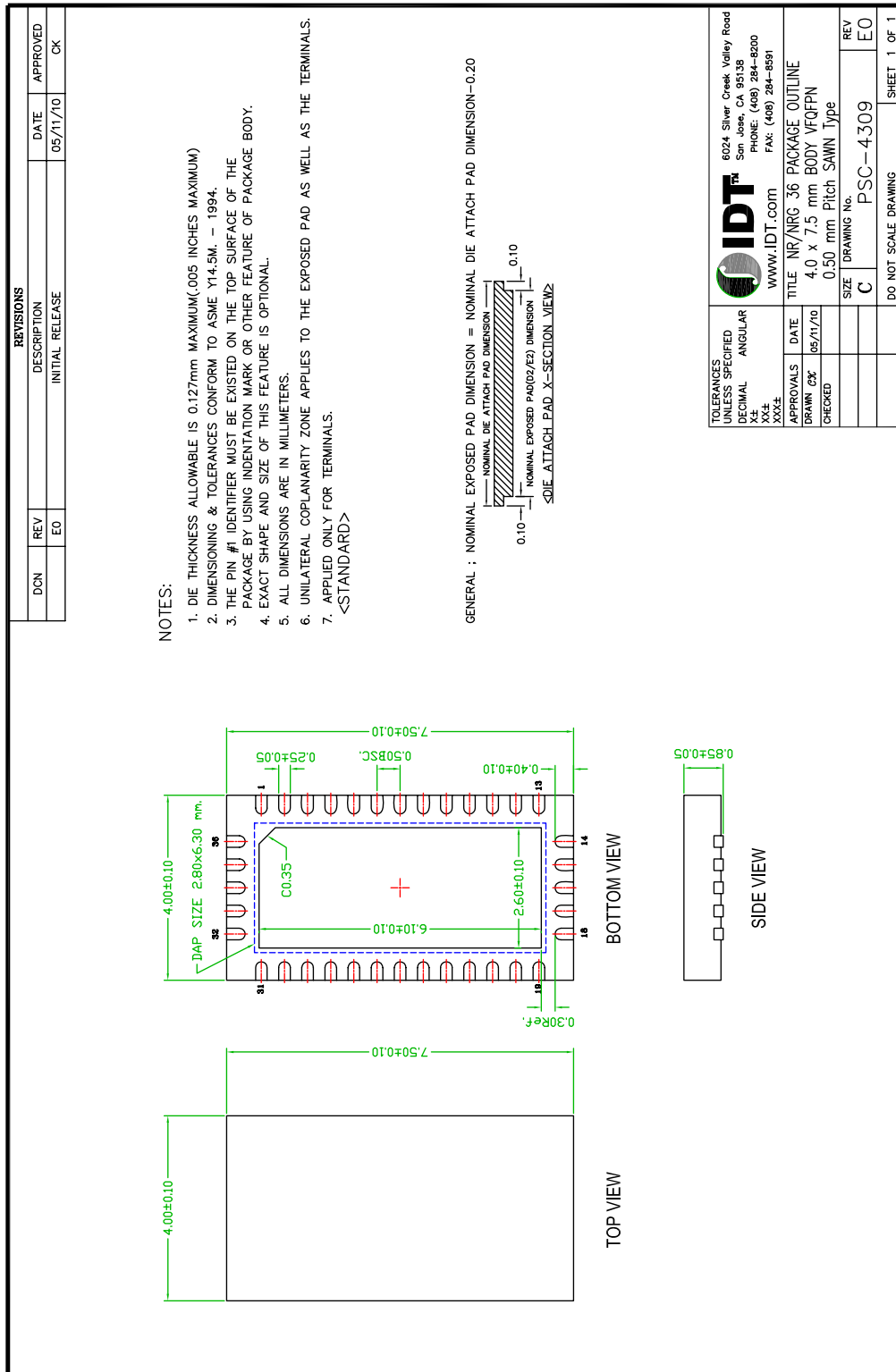

Figure 16 Pin Diagram — Top View

QFN Package Dimension



TOLERANCES UNLESS SPECIFIED	IDT™	6024 Silver Creek Valley Road San Jose, CA 95138 PHONE: (408) 284-8200 FAX: (408) 284-8991
DECIMAL	www.IDT.com	
ANGULAR		
XXX±		
XXX#		
APPROVALS	DATE	TITLE
DRAWN: CJK	05/11/10	NR/NRG: 36 PACKAGE OUTLINE
CHECKED		4.0 x 7.5 mm BODY VFQFPN
		0.50 mm Pitch SAWN Type
	SIZE	DRAWING No.
	C	PSC-4309
	REV	EO
		DO NOT SCALE DRAWING
		SHEET 1 OF 1

Revision History

November 2, 2010: Initial publication of final datasheet.

February 8, 2011: Removed black packaging options from Order page.

Ordering Information

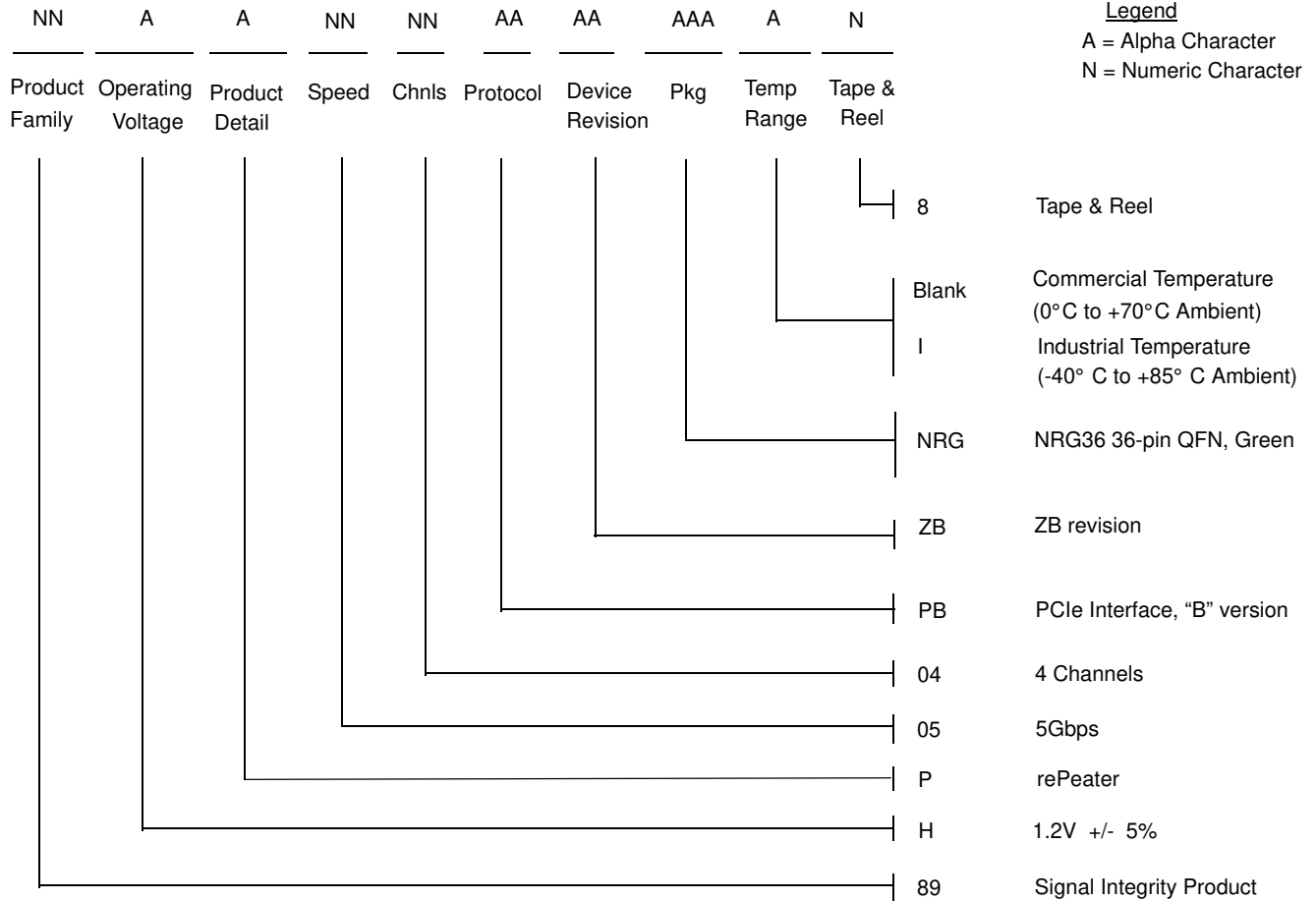

Valid Combinations

89HP0504PBZBNRG / 89HP0504PBZBNRG8 36-pin Green QFN package, Commercial Temperature

89HP0504PBZBNRGI / 89HP0504PBZBNRGI8 36-pin Green QFN package, Industrial Temperature



CORPORATE HEADQUARTERS
 6024 Silver Creek Valley Road
 San Jose, CA 95138

for SALES:
 800-345-7015 or 408-284-8200
 fax: 408-284-2775
www.idt.com

for Tech Support:
 email: siphelp@idt.com
 phone: 408-284-8208

DISCLAIMER Integrated Device Technology, Inc. (IDT) and its subsidiaries reserve the right to modify the products and/or specifications described herein at any time and at IDT's sole discretion. All information in this document, including descriptions of product features and performance, is subject to change without notice. Performance specifications and the operating parameters of the described products are determined in the independent state and are not guaranteed to perform the same way when installed in customer products. The information contained herein is provided without representation or warranty of any kind, whether express or implied, including, but not limited to, the suitability of IDT's products for any particular purpose, an implied warranty of merchantability, or non-infringement of the intellectual property rights of others. This document is presented only as a guide and does not convey any license under intellectual property rights of IDT or any third parties.

IDT's products are not intended for use in life support systems or similar devices where the failure or malfunction of an IDT product can be reasonably expected to significantly affect the health or safety of users. Anyone using an IDT product in such a manner does so at their own risk, absent an express, written agreement by IDT.

Integrated Device Technology, IDT and the IDT logo are registered trademarks of IDT. Other trademarks and service marks used herein, including protected names, logos and designs, are the property of IDT or their respective third party owners.

Copyright 2011. All rights reserved.