

FSL206MR

Green Mode Fairchild Power Switch (FPS™)

Features

- Internal Avalanche Rugged SenseFET: 650V
- Precision Fixed Operating Frequency: 67kHz
- No-Load <150mW at 265V_{AC} without Bias Winding; <25mW with Bias Winding
- No Need for Auxiliary Bias Winding
- Frequency Modulation for Attenuating EMI
- Line Under-Voltage Protection (LUVF)
- Pulse-by-Pulse Current Limiting
- Low Under-Voltage Lockout (UVLO)
- Ultra-Low Operating Current: 300μA
- Built-In Soft-Start and Startup Circuit
- Various Protections: Overload Protection (OLP), Over-Voltage Protection (OVP), Thermal Shutdown (TSD), Abnormal Over-Current Protection (AOCP), Auto-Restart Mode for All Protections

Applications

- SMPS for STB, DVD, and DVCD Player
- SMPS for Auxiliary Power

Related Resources

- [AN-4137 — Design Guidelines for Offline Flyback Converters Using FPS™](#)
- [AN-4141 — Troubleshooting and Design Tips for Fairchild Power Switch \(FPS™\) Flyback Applications](#)
- [AN-4147 — Design Guidelines for RCD Snubber of Flyback](#)
- [AN-4150 — Design Guidelines for Flyback Converters Using FSQ-Series Fairchild Power Switch \(FPS™\)](#)

Description

The FSL206MR integrated Pulse Width Modulator (PWM) and SenseFET is specifically designed for high-performance offline Switch Mode Power Supplies (SMPS) with minimal external components. This device is integrated high-voltage power regulators that combine an avalanche-rugged SenseFET with a current mode PWM control block.

The integrated PWM controller includes: 7.8V regulator for no bias winding, Under-Voltage Lockout (UVLO) Protection, Leading-Edge Blanking (LEB), an optimized gate turn-on/turn-off driver, EMI attenuator, Thermal Shutdown (TSD) protection, temperature-compensated precision current sources for loop compensation, and fault-protection circuitry such as Overload Protection (OLP), Over-Voltage Protection (OVP), Abnormal Over-Current Protection (AOCP) and Line Under-Voltage Protection (LUVF). During startup, the FSL206MR offers good soft-start performance.

The internal high-voltage startup switch and the burst-mode operation with very low operating current reduce the power loss in standby mode. As a result, it is possible to reach power loss of 150mW with no-bias winding and 25mW with bias winding at no-load condition when the input voltage is 265V_{AC}.

Ordering Information

Part Number	Operating Temperature	Top Mark	PKG	Packing Method	Maximum Output Power Table ⁽¹⁾			
					Current Limit	R _{DS(ON),MAX}	230V _{AC} ± 15% ⁽²⁾	85 ~ 265V _{AC}
							Open Frame ⁽³⁾	Open Frame ⁽³⁾
FSL206MRN	-40 ~ 115°C	FSL206MRN	8-DIP	Rail	0.6A	19Ω	12W	7W
FSL206MRL		FSL206MRL	8-LSOP					

Notes:

1. The junction temperature can limit the maximum output power.
2. 230V_{AC} or 100/115V_{AC} with doubler. The maximum power with CCM operation.
3. Maximum practical continuous power in an open-frame design at 50°C ambient.

Application Diagram

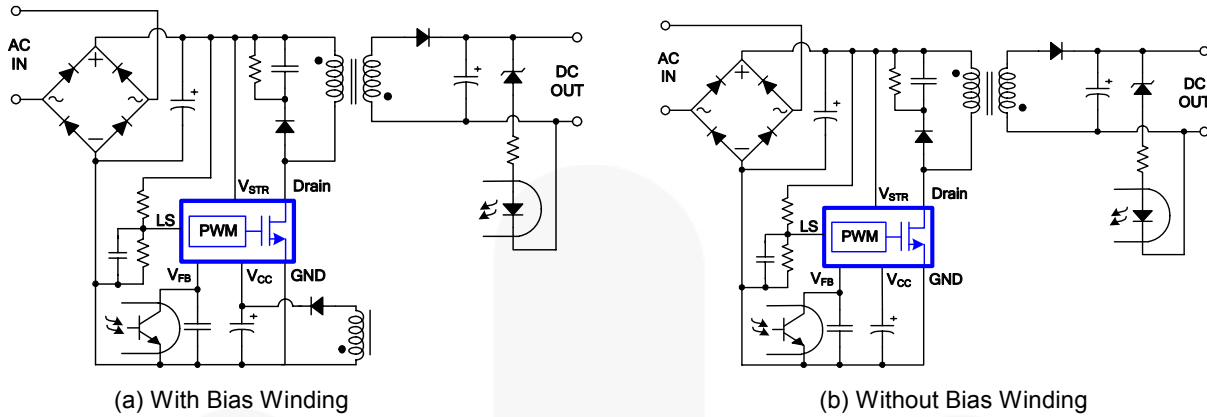

Figure 1. Typical Application

Internal Block Diagram

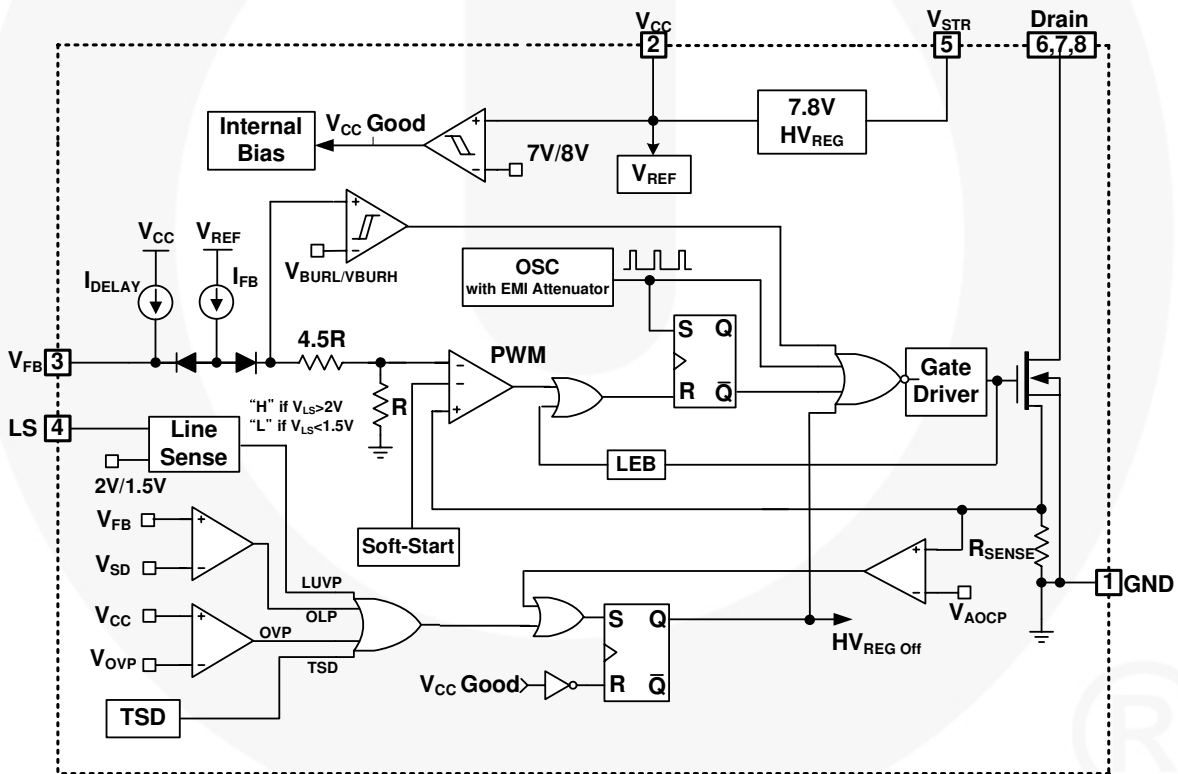

Figure 2. Internal Block Diagram

Pin Configuration

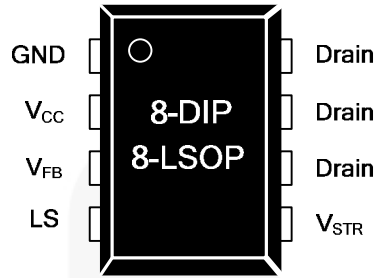

Figure 3. Pin Configuration

Pin Definitions

Pin #	Name	Description
1	GND	Ground. Sense FET source terminal on primary side and internal control ground.
2	V _{CC}	Positive Supply Voltage Input. Although connected to an auxiliary transformer winding, current is supplied from pin 5 (V _{STR}) via an internal switch during startup (see <i>Internal Block Diagram section</i>). It is not until V _{CC} reaches the UVLO upper threshold (8V) that the internal startup switch opens and device power is supplied via the auxiliary transformer winding.
3	V _{FB}	Feedback Voltage. Non-inverting input to the PWM comparator. With a 0.11mA current source connected internally and a capacitor and opto-coupler typically connected externally. There is a delay while charging external capacitor C _{FB} from 2.4V to 5V using an internal 2.7μA current source. This delay prevents false triggering under transient conditions, but allows the protection mechanism to operate under true overload conditions.
4	LS	Line Sense Pin. This pin is used to protect the set when the input voltage is lower than the rated input voltage range. If this pin is not used, connect to the ground.
5	V _{STR}	Startup. Connected to the rectified AC line voltage source. At startup, the internal switch supplies internal bias and charges an external storage capacitor placed between the V _{CC} pin and ground. Once V _{CC} reaches 8V, all internal blocks are activated. After that, the internal high-voltage regulator (HV REG) turns on and off irregularly to maintain V _{CC} at 7.8V.
6, 7, 8	Drain	Drain. Designed to connect directly to the primary lead of the transformer and capable of switching a maximum of 650V. Minimizing the length of the trace connecting these pins to the transformer decreases leakage inductance.

Absolute Maximum Ratings

Stresses exceeding the absolute maximum ratings may damage the device. The device may not function or be operable above the recommended operating conditions and stressing the parts to these levels is not recommended. In addition, extended exposure to stresses above the recommended operating conditions may affect device reliability. The absolute maximum ratings are stress ratings only. $T_A = 25^\circ\text{C}$, unless otherwise specified.

Symbol	Parameter	Min.	Max.	Unit
V_{STR}	V_{STR} Pin Voltage	-0.3	650.0	V
V_{DS}	Drain Pin Voltage	-0.3	650.0	V
V_{CC}	Supply Voltage		26	V
V_{LS}	LS Pin Voltage	-0.3	Internally Clamped Voltage ⁽⁴⁾	V
V_{FB}	Feedback Voltage Range	-0.3	Internally Clamped Voltage ⁽⁴⁾	V
I_{DM}	Drain Current Pulsed ⁽⁵⁾		1.5	A
E_{AS}	Single Pulsed Avalanche Energy ⁽⁶⁾		11	mJ
P_D	Total Power Dissipation		1.3	W
T_J	Operating Junction Temperature	-40	+150	$^\circ\text{C}$
T_A	Operating Ambient Temperature	-40	+125	$^\circ\text{C}$
T_{STG}	Storage Temperature	-55	+150	$^\circ\text{C}$
ESD	Human Body Model, JESD22-A114	4		KV
	Charged Device Model, JESD22-C101	2		

Notes:

- V_{FB} is clamped by internal clamping diode (13V , $I_{CLAMP_MAX} < 100\mu\text{A}$). After shutdown, before V_{CC} reaching V_{STOP} , $V_{SD} < V_{FB} < V_{CC}$.
- Repetitive rating: Pulse width limited by maximum junction temperature.
- $L=21\text{mH}$, starting $T_J=25^\circ\text{C}$.

Thermal Impedance

$T_A=25^\circ\text{C}$ unless otherwise specified.

Symbol	Parameter	Package	Value	Unit
θ_{JA}	Junction-to-Ambient Thermal Impedance ⁽⁷⁾	8-DIP	93	$^\circ\text{C/W}$

Notes:

- Referenced the JEDEC recommended environment, JESD51-2, bv and test board, JESD51-10, with minimum land pattern.

Electrical Characteristics

T_A = 25°C unless otherwise specified.

Symbol	Parameter	Conditions	Min.	Typ.	Max.	Units
SenseFET Section						
B _V DSS	Drain Source Breakdown Voltage	V _{CC} = 0V, I _D = 250μA	650			V
I _D SS	Zero Gate Voltage Drain Current	V _{DS} = 650V, V _{GS} = 0V			50	μA
		V _{DS} = 520V, V _{GS} = 0V, T _A = 125°C ⁽⁸⁾			250	μA
R _{DS(ON)}	Drain-Source On-State Resistance ⁽⁹⁾	V _{GS} = 10V, I _D = 0.3A		14	19	Ω
C _i SS	Input Capacitances	V _{GS} = 0V, V _{DS} = 25V, f = 1MHz		162		pF
C _O SS	Output Capacitance	V _{GS} = 0V, V _{DS} = 25V, f = 1MHz		14.9		pF
C _R SS	Reverse Transfer Capacitance	V _{GS} = 0V, V _{DS} = 25V, f = 1MHz		2.7		pF
t _r	Rise Time	V _{DS} = 325V, I _D = 0.5A, R _G =25Ω		6.1		ns
t _f	Fall Time	V _{DS} = 325V, I _D = 0.5A, R _G =25Ω		43.6		ns
Control Section						
f _{OSC}	Switching Frequency	V _{FB} = 4V, V _{CC} = 10V	61	67	73	KHz
Δf _{OSC}	Switching Frequency Variation	-25°C < T _J < 85°C		±5	±10	%
f _M	Frequency Modulation ⁽⁸⁾			±3		KHz
D _{MAX}	Maximum Duty Cycle	V _{FB} = 4V, V _{CC} = 10V	66	72	78	%
D _{MIN}	Minimum Duty Cycle	V _{FB} = 0V, V _{CC} = 10V	0	0	0	%
V _{START}	UVLO Threshold Voltage	V _{FB} = 0V, V _{CC} Sweep	7	8	9	V
V _{STOP}		After Turn On	6	7	8	V
I _{FB}	Feedback Source Current	V _{FB} = 0V, V _{CC} = 10V	90	110	130	μA
t _{S/S}	Internal Soft-Start Time	V _{FB} = 4V, V _{CC} = 10V	10	15	20	ms
Burst Mode Section						
V _{BURH}	Burst-Mode HIGH Threshold Voltage	V _{CC} = 10V, V _{FB} Increase	0.66	0.83	1.00	V
V _{BURL}	Burst-Mode LOW Threshold Voltage	V _{CC} = 10V, V _{FB} Decrease	0.59	0.74	0.89	V
HYS _{BUR}	Burst-Mode Hysteresis			90		mV
Protection Section						
I _{LIM}	Peak Current Limit	V _{FB} = 4V, di/dt = 300mA/μs, V _{CC} = 10V	0.54	0.60	0.66	A
t _{CLD}	Current Limit Delay Time ⁽⁸⁾			100		ns
V _{SD}	Shutdown Feedback Voltage	V _{CC} = 10V	4.5	5.0	5.5	V
I _{DELAY}	Shutdown Delay Current	V _{FB} = 4V	2.1	2.7	3.3	μA
t _{LEB}	Leading-Edge Blanking Time ⁽⁸⁾		250			ns
V _{AOCP}	Abnormal Over-Current Protection ⁽⁸⁾			0.7		V
V _{OVP}	Over-Voltage Protection	V _{FB} = 4V, V _{CC} Increase	23.0	24.5	26.0	V
V _{LS_OFF}	Line-Sense Protection On to Off	V _{FB} = 3V, V _{CC} = 10V, V _{LS} Decrease	1.9	2.0	2.1	V
V _{LS_ON}	Line-Sense Protection Off to On	V _{FB} = 3V, V _{CC} = 10V, V _{LS} Increase	1.4	1.5	1.6	V
TSD	Thermal Shutdown Temperature ⁽⁸⁾		+125	+135	+150	°C
HYS _{TSD}	TSD Hysteresis Temperature ⁽⁸⁾			+60		°C

Electrical Characteristics (Continued)T_A = 25°C unless otherwise specified.

Symbol	Parameter	Conditions	Min.	Typ.	Max.	Units
High Voltage Regulator Section						
V _{HVR}	HV Regulator Voltage	V _{FB} = 0V, V _{STR} = 40V		7.8		V
Total Device Section						
I _{OP1}	Operating Supply Current (Control Part Only, without Switching)	V _{CC} = 15V, 0V < V _{FB} < V _{BURL}		0.3	0.5	mA
I _{OP2}	Operating Supply Current (Control Part Only, without Switching)	V _{CC} = 8V, 0V < V _{FB} < V _{BURL}		0.25	0.45	mA
I _{OP3}	Operating Supply Current ⁽⁸⁾ (While Switching)	V _{CC} = 15V, V _{BURL} < V _{FB} < V _{SD}			1.3	mA
I _{CH}	Startup Charging Current	V _{CC} = 0V, V _{STR} > 40V	1.6	1.9	2.2	mA
I _{START}	Startup Current	V _{CC} = before V _{START} , V _{FB} = 0V		100	150	μA
V _{STR}	Minimum V _{STR} Supply Voltage	V _{CC} = V _{FB} = 0V, V _{STR} Increase		26		V

Notes:

8. Though guaranteed by design, not 100% tested in production.
9. Pulse test: pulse width=300ms, duty cycle=2%.

Typical Performance Characteristics

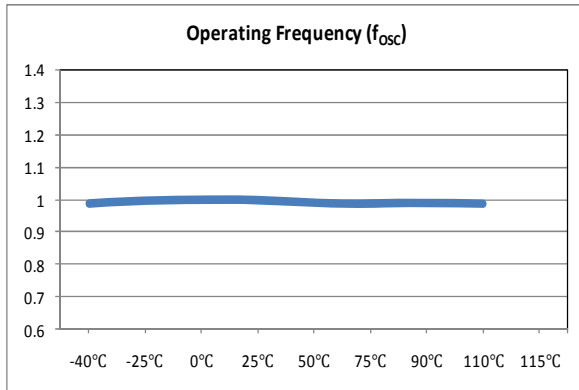

Figure 4. Operating Frequency vs. Temperature

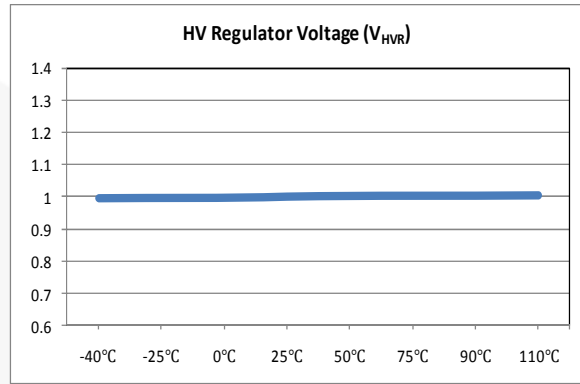

Figure 5. HV Regulator Voltage vs. Temperature

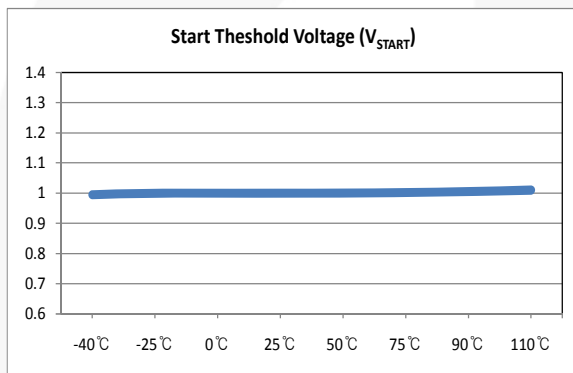

Figure 6. Start Threshold Voltage vs. Temperature

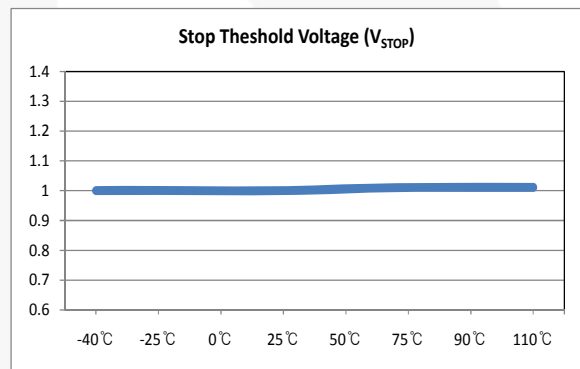

Figure 7. Stop Threshold Voltage vs. Temperature

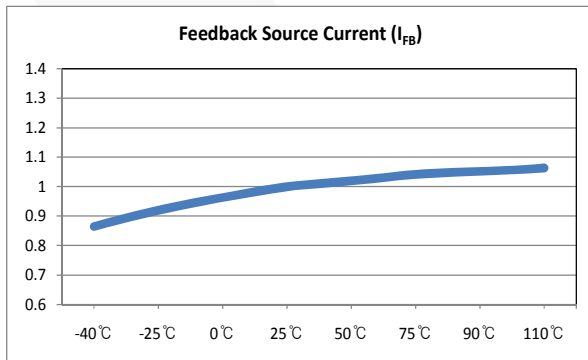

Figure 8. Feedback Source Current vs. Temperature

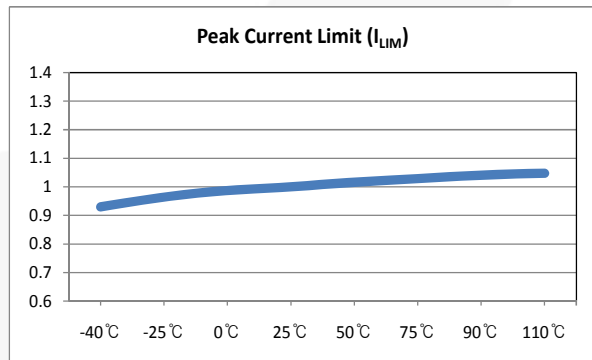

Figure 9. Peak Current Limit vs. Temperature

Typical Performance Characteristics (Continued)

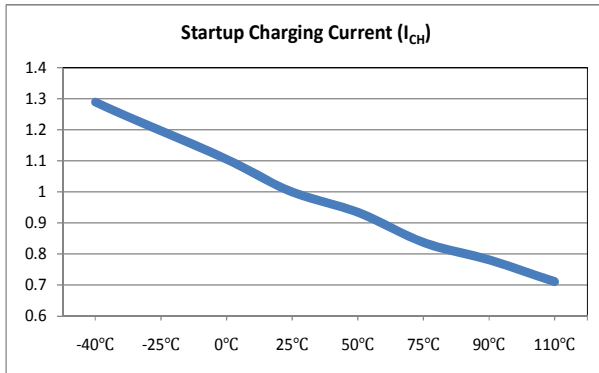

Figure 10. Startup Charging Current vs. Temperature

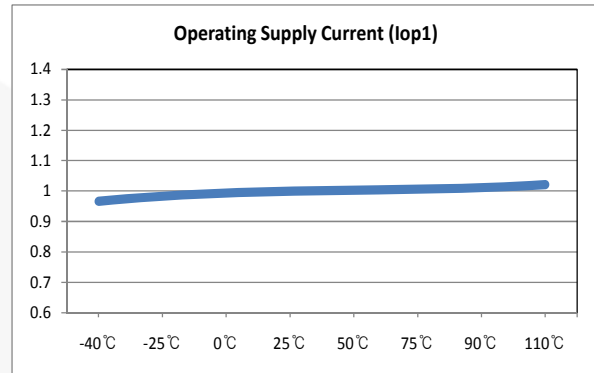

Figure 11. Operating Supply Current 1 vs. Temperature

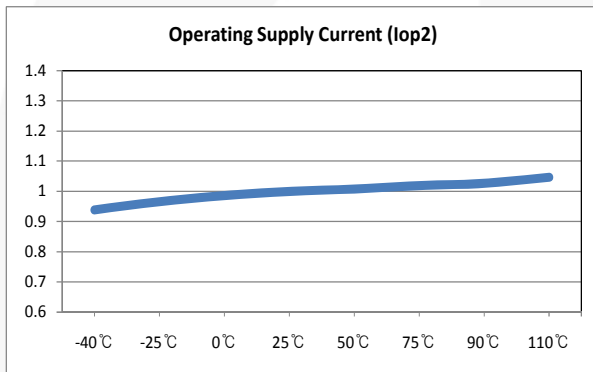

Figure 12. Operating Supply Current 2 vs. Temperature

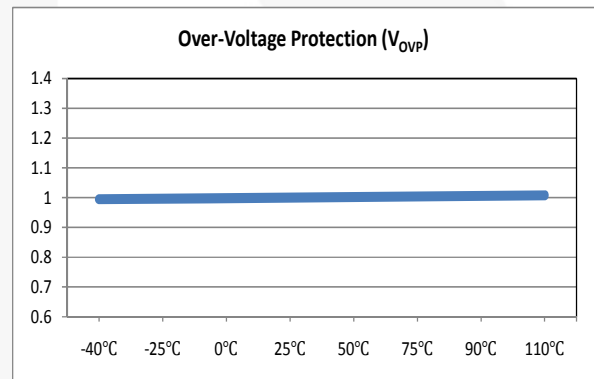

Figure 13. Over-Voltage Protection Voltage vs. Temperature

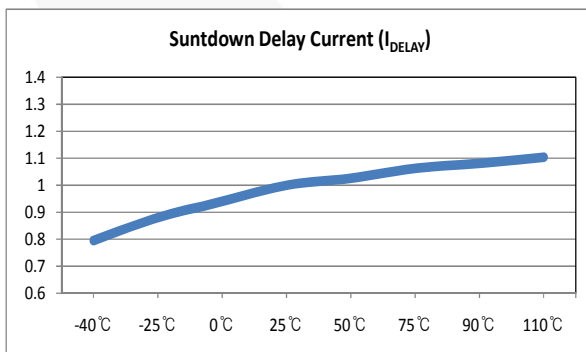

Figure 14. Shutdown Delay Current vs. Temperature

Functional Description

Startup

At startup, an internal high-voltage current source supplies the internal bias and charges the external capacitor (C_A) connected to the V_{CC} pin, as illustrated in Figure 15. An internal high-voltage regulator (HV/REG) located between the V_{STR} and V_{CC} pins regulates the V_{CC} to be 7.8V and supplies operating current. Therefore, FSL206MR needs no auxiliary bias winding.

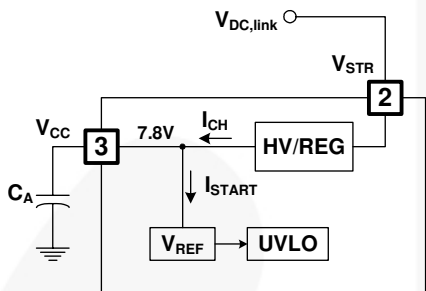

Figure 15. Startup Block

Oscillator Block

The oscillator frequency is set internally and the FPS™ has a random frequency fluctuation function.

Fluctuation of the switching frequency of a switched power supply can reduce EMI by spreading the energy over a wider frequency range than the bandwidth measured by the EMI test equipment. The amount of EMI reduction is directly related to the range of the frequency variation. The range of frequency variation is fixed internally; however, its selection is randomly chosen by the combination of external feedback voltage and internal free-running oscillator. This randomly chosen switching frequency effectively spreads the EMI noise nearby switching frequency and allows the use of a cost-effective inductor instead of an AC input line filter to satisfy world-wide EMI requirements.

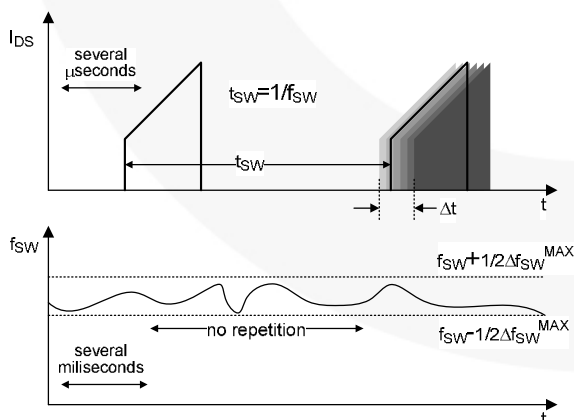

Figure 16. Frequency Fluctuation Waveform

Feedback Control

FSL206MR employs current-mode control, as shown in Figure 17. An opto-coupler (such as the FOD817A) and shunt regulator (such as the KA431) are typically used to implement the feedback network. Comparing the feedback voltage with the voltage across the R_{SENSE} resistor makes it possible to control the switching duty cycle. When the shunt regulator reference pin voltage exceeds the internal reference voltage of 2.5V; the opto-coupler LED current increases, feedback voltage V_{FB} is pulled down, and the duty cycle is reduced. This typically occurs when input voltage is increased or output load is decreased.

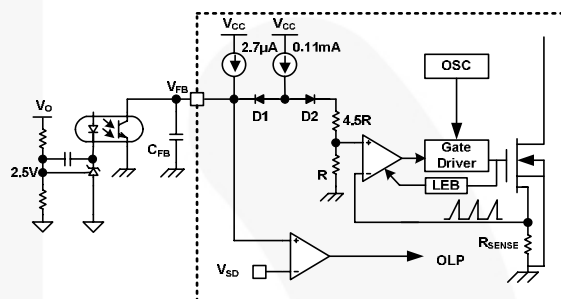

Figure 17. Pulse-Width-Modulation (PWM) Circuit

Leading-Edge Blanking (LEB)

At the instant the internal SenseFET is turned on, the primary-side capacitance and secondary-side rectifier diode reverse recovery typically causes a high-current spike through the SenseFET. Excessive voltage across the R_{SENSE} resistor leads to incorrect feedback operation in the current mode PWM control. To counter this effect, the FPS employs a leading-edge blanking (LEB) circuit (see Figure 17). This circuit inhibits the PWM comparator for a short time (t_{LEB}) after the SenseFET is turned on.

Protection Circuits

The FSL206MR protective functions, include Overload Protection (OLP), Over-Voltage Protection (OVP), Under-Voltage Lockout (UVLO), Line Under-Voltage Protection (LUVP), Abnormal Over-Current Protection (AOCP), and thermal shutdown (TSD). Because these protection circuits are fully integrated inside the IC without external components, reliability is improved without increasing cost. Once a fault condition occurs, switching is terminated and the SenseFET remains off. This causes V_{CC} to fall. When V_{CC} reaches the UVLO stop voltage V_{STOP} (7V), the protection is reset and the internal high-voltage current source charges the V_{CC} capacitor via the V_{STR} pin. When V_{CC} reaches the UVLO start voltage V_{START} (8V), the FPS resumes normal operation. In this manner, the auto-restart can alternately enable and disable the switching of the power SenseFET until the fault condition is eliminated.

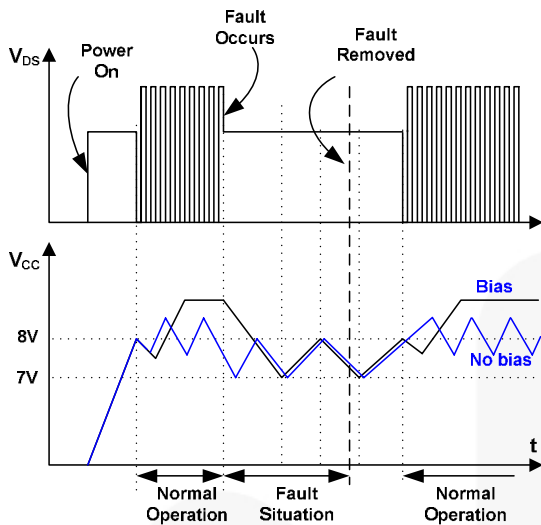

Figure 18. Auto-Restart Protection Waveforms

Overload Protection (OLP)

Overload is defined as the load current exceeding a pre-set level due to an unexpected event. In this situation, the protection circuit should be activated to protect the SMPS. However, even when the SMPS is operating normally, the overload protection (OLP) circuit can be activated during the load transition or startup. To avoid this undesired operation, the OLP circuit is activated after a specified time to determine whether it is a transient situation or a true overload situation. The current-mode feedback path limits the current in the SenseFET when the maximum PWM duty cycle is attained. If the output consumes more than this maximum power, the output voltage (V_O) decreases below its rating voltage. This reduces the current through the opto-coupler LED, which also reduces the opto-coupler transistor current, thus increasing the feedback voltage (V_{FB}). If V_{FB} exceeds 2.4V, the feedback input diode is blocked and the 2.7 μ A current source (I_{DELAY}) starts to charge C_{FB} slowly up. In this condition, V_{FB} increases until it reaches 5V, when the switching operation is terminated, as shown in Figure 19. The shutdown delay time is the time required to charge C_{FB} from 2.4V to 5V with 2.7 μ A current source.

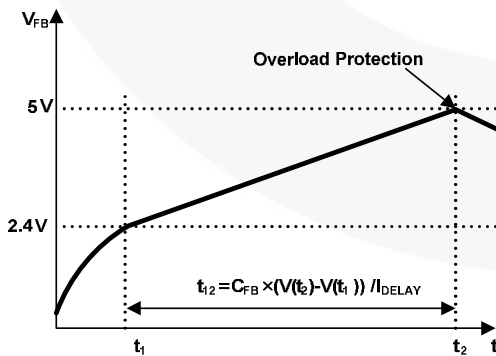

Figure 19. Overload Protection (OLP)

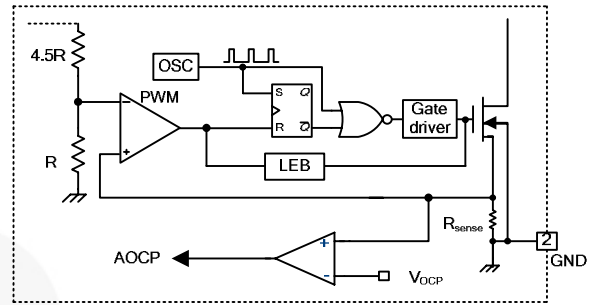

Figure 20. Abnormal Over-Current Protection

Abnormal Over-Current Protection (AOCP)

When the secondary rectifier diodes or the transformer pin are shorted, a steep current with extremely high di/dt can flow through the SenseFET during the LEB time. Even though the FPS has overload protection, it is not enough to protect the FPS in that abnormal case, since severe current stress is imposed on the SenseFET until OLP triggers. The FPS includes the internal AOCP (Abnormal Over-Current Protection) circuit shown in Figure 20. When the gate turn-on signal is applied to the power sense, the AOCP block is enabled and monitors the current through the sensing resistor. The voltage across the resistor is compared with a preset AOCP level. If the sensing resistor voltage is greater than the AOCP level, the set signal is applied to the latch, resulting in the shutdown of the SMPS.

Thermal Shutdown (TSD)

The SenseFET and the control IC are integrated, making it easier to detect the temperature of the SenseFET. When the junction temperature exceeds approximately 135°C, thermal shutdown is activated and the FPS is restarted after decreasing temperature reaches 60°C.

Over-Voltage Protection (OVP)

In the event of a malfunction in the secondary-side feedback circuit or an open feedback loop caused by a soldering defect, the current through the opto-coupler transistor becomes almost zero (refer to Figure 17). Then, V_{FB} climbs up in a similar manner to the overload situation, forcing the preset maximum current to be supplied to the SMPS until the overload protection is activated. Because excess energy is provided to the output, the output voltage may exceed the rated voltage before the overload protection is activated, resulting in the breakdown of the devices in the secondary side. To prevent this situation, an over-voltage protection (OVP) circuit is employed. In general, V_{CC} is proportional to the output voltage and the FPS uses V_{CC} instead of directly monitoring the output voltage. If V_{CC} exceeds 24.5V, OVP circuit is activated, resulting in termination of the switching operation. To avoid undesired activation of OVP during normal operation, V_{CC} should be properly designed to be below 24.5V.

Line Under-Voltage Protection (LUVP)

If the input voltage of the converter is lower than the minimum operating voltage, the converter input current increases too much, causing components failure. If the input voltage is low, the converter should be protected. In the FSL206MR, the LUVP circuit senses the input voltage using the LS pin and, if this voltage is lower than 1.5V, the LUVP signal is generated. The comparator has 0.5V hysteresis. If the LUVP signal is generated, the output drive block is shut down and the output voltage feedback loop is saturated.

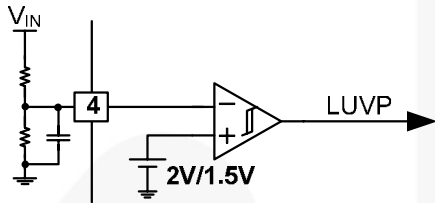

Figure 21. Line UVP Circuit

Soft-Start

The FSL206MR has an internal soft-start circuit that slowly increases the feedback voltage, together with the SenseFET current, after it starts up. The typical soft-start time is 15ms, as shown in Figure 22, where progressive increments of the SenseFET current are allowed during the startup phase. The pulse width to the power switching device is progressively increased to establish the correct working conditions for transformers, inductors, and capacitors. The voltage on the output capacitors is progressively increased with the intention of smoothly establishing the required output voltage. It also helps prevent transformer saturation and reduce the stress on the secondary diode.

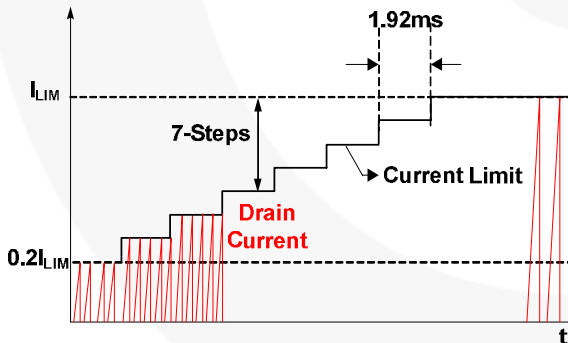

Figure 22. Internal Soft-Start

Burst Operation

To minimize power dissipation in standby mode, the FPS enters burst mode. As the load decreases, the feedback voltage decreases. As shown in Figure 23, the device automatically enters burst mode when the feedback voltage drops below V_{BURH} . Switching continues until the feedback voltage drops below V_{BURL} . At this point, switching stops and the output voltages start to drop at a rate dependent on the standby current load. This causes the feedback voltage to rise. Once it passes V_{BURH} , switching resumes. The feedback voltage then falls and the process repeats. Burst mode alternately enables and disables switching of the SenseFET and reduces switching loss in standby mode.

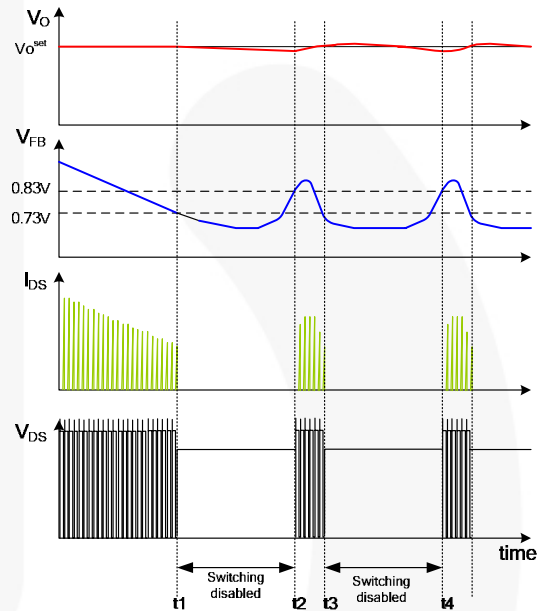
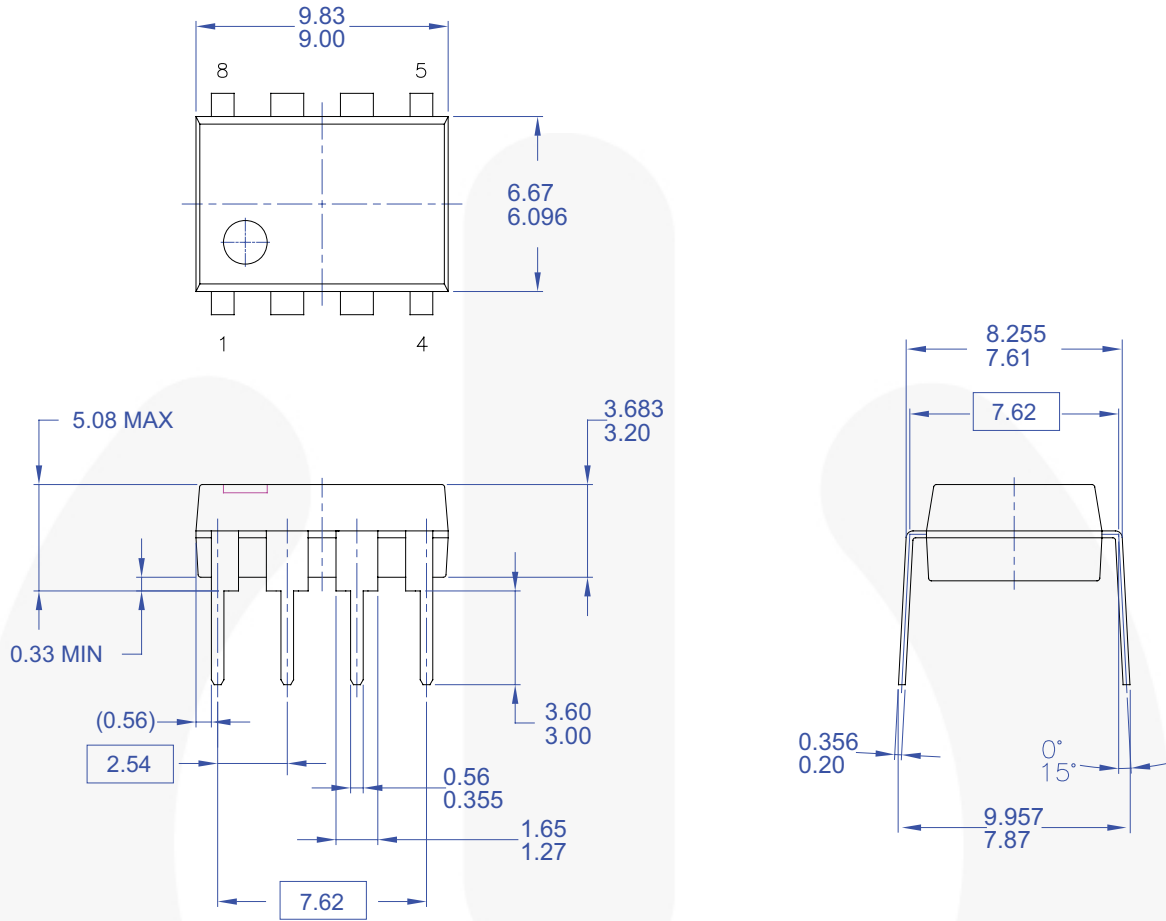

Figure 23. Burst-Mode Operation

Physical Dimensions



- NOTES: UNLESS OTHERWISE SPECIFIED
- A) THIS PACKAGE CONFORMS TO JEDEC MS-001 VARIATION BA
 - B) ALL DIMENSIONS ARE IN MILLIMETERS.
 - C) DIMENSIONS ARE EXCLUSIVE OF BURRS, MOLD FLASH, AND TIE BAR EXTRUSIONS.
 - D) DIMENSIONS AND TOLERANCES PER ASME Y14.5M-1994
 - E) DRAWING FILENAME AND REVISION: MKT-N08FREV2.

Figure 24. 8-Lead, Dual In-Line Package (DIP)

Package drawings are provided as a service to customers considering Fairchild components. Drawings may change in any manner without notice. Please note the revision and/or date on the drawing and contact a Fairchild Semiconductor representative to verify or obtain the most recent revision. Package specifications do not expand the terms of Fairchild's worldwide terms and conditions, specifically the warranty therein, which covers Fairchild products.

Always visit Fairchild Semiconductor's online packaging area for the most recent package drawings:
<http://www.fairchildsemi.com/packaging/>

Physical Dimensions (Continued)

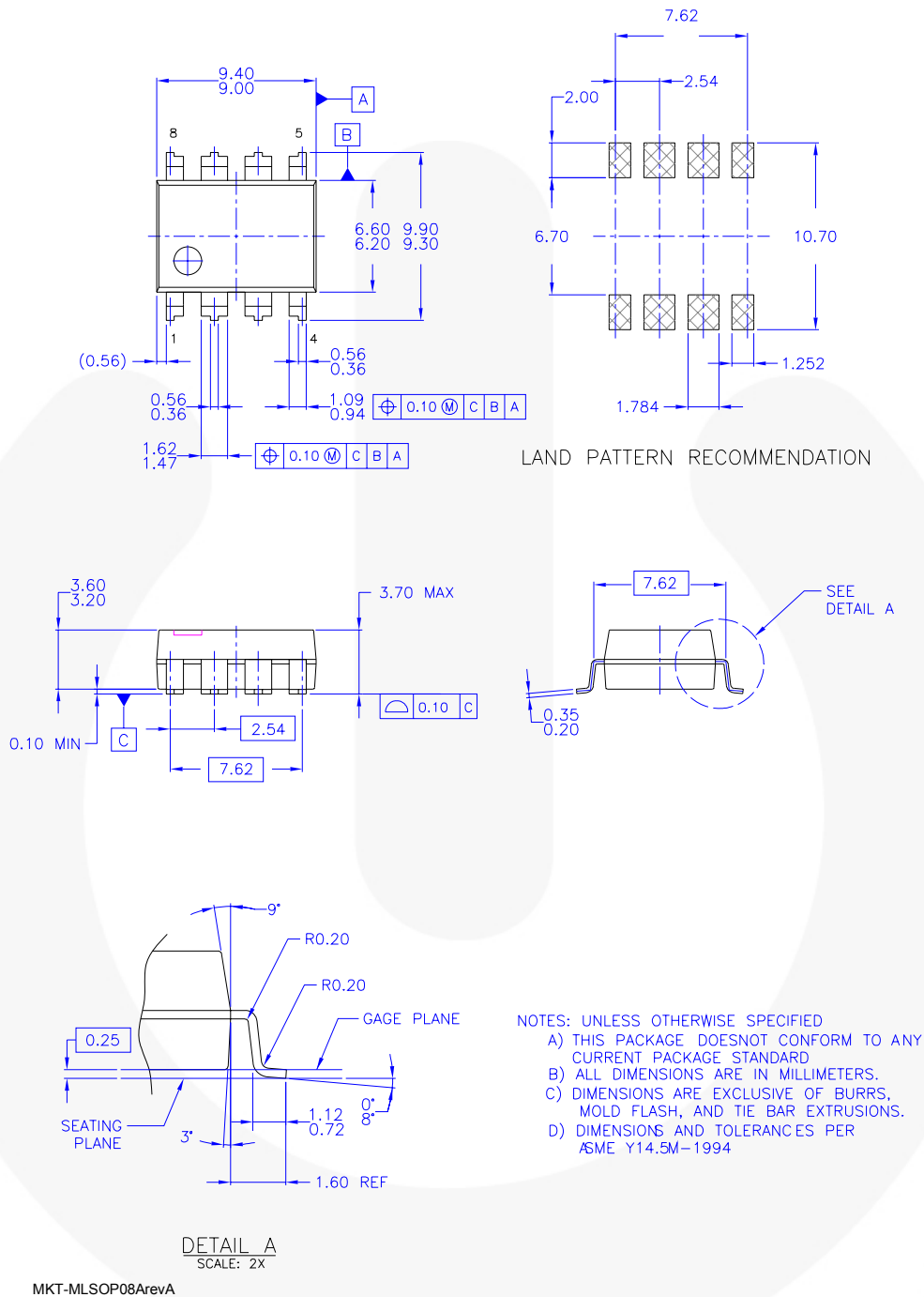

Figure 25. 8-Lead, .300" Wide, Surface Mount Package (LSOP)

Package drawings are provided as a service to customers considering Fairchild components. Drawings may change in any manner without notice. Please note the revision and/or date on the drawing and contact a Fairchild Semiconductor representative to verify or obtain the most recent revision. Package specifications do not expand the terms of Fairchild's worldwide terms and conditions, specifically the warranty therein, which covers Fairchild products.

Always visit Fairchild Semiconductor's online packaging area for the most recent package drawings:
<http://www.fairchildsemi.com/packaging/>



TRADEMARKS

The following includes registered and unregistered trademarks and service marks, owned by Fairchild Semiconductor and/or its global subsidiaries, and is not intended to be an exhaustive list of all such trademarks.

- | | | | |
|--------------------------|------------------------|---------------------------------------|---|
| AccuPower™ | F-PFS™ | Power-SPM™ | <p>SYSTEM GENERAL
The Power Franchise®</p> <p>the power franchise</p> <p>TinyBoost™
TinyBuck™
TinyCalc™
TinyLogic™
TINYOPTO™
TinyPower™
TinyPWM™
TinyWire™
TriFault Detect™
TRUECURRENT™
µSerDes™</p> <p>µSerDes
UHC®
Ultra FRFET™
UniFET™
VCX™
VisualMax™
XS™</p> |
| Auto-SPM™ | FRFET® | PowerTrench® | |
| Build it Now™ | Global Power Resource™ | PowerXS™ | |
| CorePLUS™ | Green FPS™ | Programmable Active Droop™ | |
| CorePOWER™ | Green FPS™ e-Series™ | QFET® | |
| CROSSVOL™ | Gmax™ | QST™ | |
| CTL™ | GTO™ | Quiet Series™ | |
| Current Transfer Logic™ | IntelliMAX™ | RapidConfigure™ | |
| DEUXPEED® | ISOPLANAR™ | ™ | |
| Dual Cool™ | MegaBuck™ | Saving our world, 1mW/W/kW at a time™ | |
| EcoSPARK® | MICROCOUPLER™ | SignalWise™ | |
| EfficientMax™ | MicroFET™ | SmartMax™ | |
| ESBC™ | MicroPak™ | SMART START™ | |
| ™ | MicroPak2™ | SPM® | |
| Fairchild® | MillerDrive™ | STEALTH™ | |
| Fairchild Semiconductor® | MotionMax™ | SuperFET™ | |
| FACT Quiet Series™ | Motion-SPM™ | SuperSOT™.3 | |
| FACT® | OptoHIT™ | SuperSOT™.6 | |
| FACT® | OPTOLOGIC® | SuperSOT™.8 | |
| FastvCore™ | OPTOPLANAR® | SupreMOS® | |
| FETBench™ | ™ | SyncFET™ | |
| FlashWriter® | | Sync-Lock™ | |
| FPS™ | | | |

* Trademarks of System General Corporation, used under license by Fairchild Semiconductor.

DISCLAIMER

FAIRCHILD SEMICONDUCTOR RESERVES THE RIGHT TO MAKE CHANGES WITHOUT FURTHER NOTICE TO ANY PRODUCTS HEREIN TO IMPROVE RELIABILITY, FUNCTION, OR DESIGN. FAIRCHILD DOES NOT ASSUME ANY LIABILITY ARISING OUT OF THE APPLICATION OR USE OF ANY PRODUCT OR CIRCUIT DESCRIBED HEREIN; NEITHER DOES IT CONVEY ANY LICENSE UNDER ITS PATENT RIGHTS, NOR THE RIGHTS OF OTHERS. THESE SPECIFICATIONS DO NOT EXPAND THE TERMS OF FAIRCHILD'S WORLDWIDE TERMS AND CONDITIONS, SPECIFICALLY THE WARRANTY THEREIN, WHICH COVERS THESE PRODUCTS.

LIFE SUPPORT POLICY

FAIRCHILD'S PRODUCTS ARE NOT AUTHORIZED FOR USE AS CRITICAL COMPONENTS IN LIFE SUPPORT DEVICES OR SYSTEMS WITHOUT THE EXPRESS WRITTEN APPROVAL OF FAIRCHILD SEMICONDUCTOR CORPORATION.

As used herein:

1. Life support devices or systems are devices or systems which, (a) are intended for surgical implant into the body or (b) support or sustain life, and (c) whose failure to perform when properly used in accordance with instructions for use provided in the labeling, can be reasonably expected to result in a significant injury of the user.
2. A critical component in any component of a life support, device, or system whose failure to perform can be reasonably expected to cause the failure of the life support device or system, or to affect its safety or effectiveness.

ANTI-COUNTERFEITING POLICY

Fairchild Semiconductor Corporation's Anti-Counterfeiting Policy. Fairchild's Anti-Counterfeiting Policy is also stated on our external website, www.fairchildsemi.com, under Sales Support.

Counterfeiting of semiconductor parts is a growing problem in the industry. All manufacturers of semiconductor products are experiencing counterfeiting of their parts. Customers who inadvertently purchase counterfeit parts experience many problems such as loss of brand reputation, substandard performance, failed applications, and increased cost of production and manufacturing delays. Fairchild is taking strong measures to protect ourselves and our customers from the proliferation of counterfeit parts. Fairchild strongly encourages customers to purchase Fairchild parts either directly from Fairchild or from Authorized Fairchild Distributors who are listed by country on our web page cited above. Products customers buy either from Fairchild directly or from Authorized Fairchild Distributors are genuine parts, have full traceability, meet Fairchild's quality standards for handling and storage and provide access to Fairchild's full range of up-to-date technical and product information. Fairchild and our Authorized Distributors will stand behind all warranties and will appropriately address any warranty issues that may arise. Fairchild will not provide any warranty coverage or other assistance for parts bought from Unauthorized Sources. Fairchild is committed to combat this global problem and encourage our customers to do their part in stopping this practice by buying direct or from authorized distributors.

PRODUCT STATUS DEFINITIONS

Definition of Terms

Datasheet Identification	Product Status	Definition
Advance Information	Formative / In Design	Datasheet contains the design specifications for product development. Specifications may change in any manner without notice.
Preliminary	First Production	Datasheet contains preliminary data; supplementary data will be published at a later date. Fairchild Semiconductor reserves the right to make changes at any time without notice to improve design.
No Identification Needed	Full Production	Datasheet contains final specifications. Fairchild Semiconductor reserves the right to make changes at any time without notice to improve the design.
Obsolete	Not In Production	Datasheet contains specifications on a product that is discontinued by Fairchild Semiconductor. The datasheet is for reference information only.

Rev. 149