

6

5

4

3

2

74720

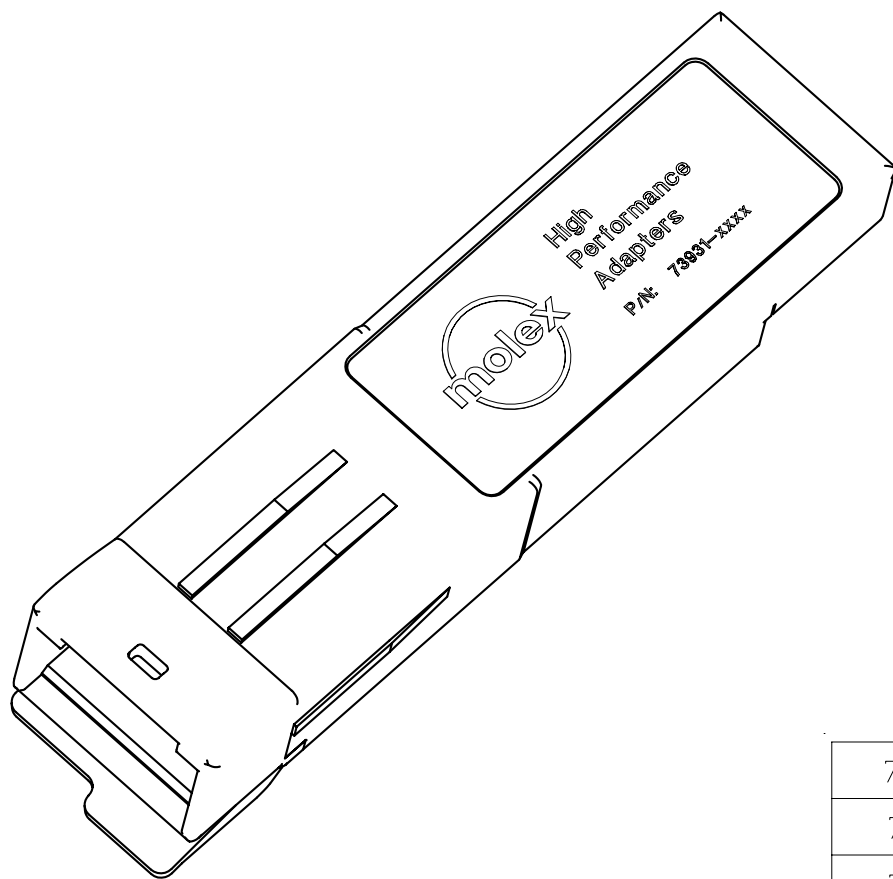

1. Mates to SFP components which comply to standard MSA dimension specifications; accepts plugs conforming to HSSDC2 specs.
2. Robust zinc die cast body, bright tin plated. Mounts belly-to-belly using .093"+ boards.
3. Raised wedges assure electrical contact with surrounding EMI cage assembly.
4. Spring loaded latch releases with simple squeeze, and pull action.
5. Keying and electrical performance meets Infiniband and Fiber Channel callouts.
6. 100 or 150 ohm versions available.
7. Supports serial ID functionality.
8. Up to 2.5 Gb/s data rates.
9. 3.3V or 5V single supply.
10. Hot pluggable.

74720-0202	FIBER CHANNEL KEY, 150 OHM ACTIVE WITH SERIAL ID		
74720-0201	FIBER CHANNEL KEY, 150 OHM ACTIVE W/O SERIAL ID		
74720-0102	INFINIBAND KEY, 100 OHM ACTIVE WITH SERIAL ID		
74720-0101	INFINIBAND KEY, 100 OHM ACTIVE W/O SERIAL ID		
SCALE 6:1	DESIGN UNITS METRIC	THIRD ANGLE PROJECTION	REVISE ON CAD ONLY
DIMENSION STYLE MM/IN		TITLE ADAPTER, HSSDC2 TO SFP	
DRAWN BY DIRKERS	DATE 2001/06/15	MOLEX INCORPORATED	
CHECKED BY DIRKERS	DATE 2001/06/15	MATERIAL NO. SEE TABLE	DOCUMENT NO. SD-74720-101
APPROVED BY	DATE	SHEET NO. 1 OF 3	A
THIS DRAWING CONTAINS INFORMATION THAT IS PROPRIETARY TO MOLEX INCORPORATED AND SHOULD NOT BE USED WITHOUT WRITTEN PERMISSION			

INITIAL SALES DRAWING EC NO: UDT2001-1462 DRWN: DIRKERS 2001/06/15 CHKD: DIRKERS 2001/06/15 APPR: BRUSSELL 2001/06/19	QUALITY SYMBOLS ▽ = 0 ∇ = 0
DESCRIPTION REV	

GENERAL TOLERANCES
(UNLESS SPECIFIED)

	mm	INCH
4 PLACES	± ---	± ---
3 PLACES	± ---	± .005
2 PLACES	± 0.13	± ---
1 PLACE	± ---	± ---

ANGULAR ±1/2°

DRAFT WHERE APPLICABLE
MUST REMAIN
WITHIN DIMENSIONS

74720

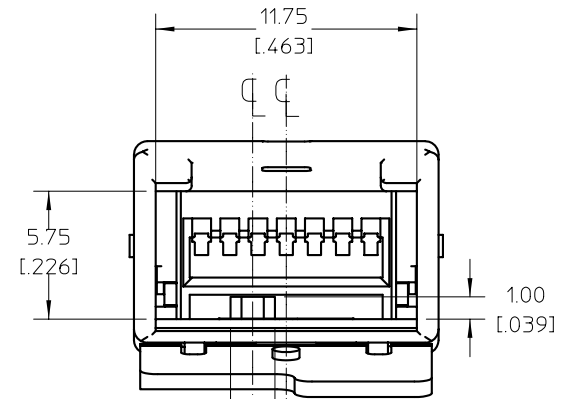
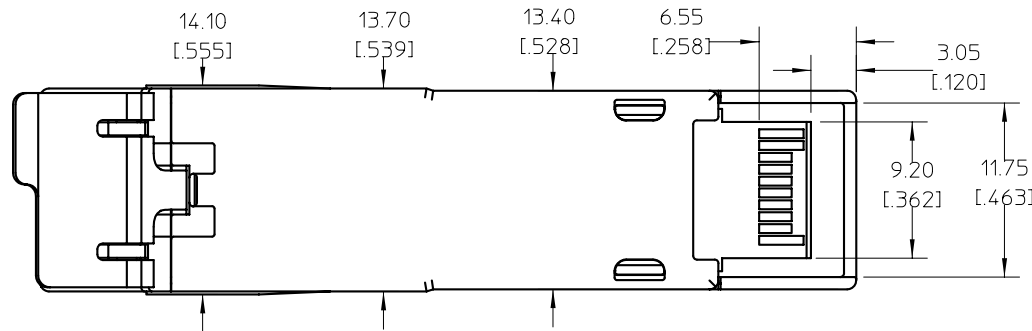
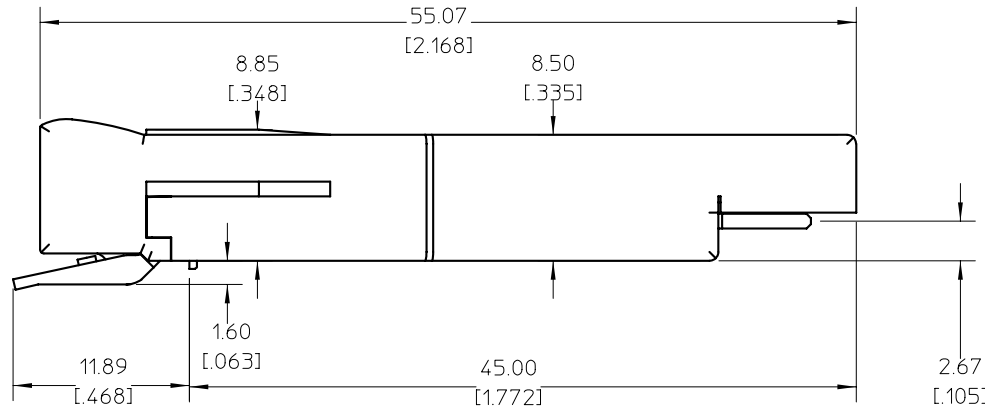

FIBER CHANNEL KEY 3:1

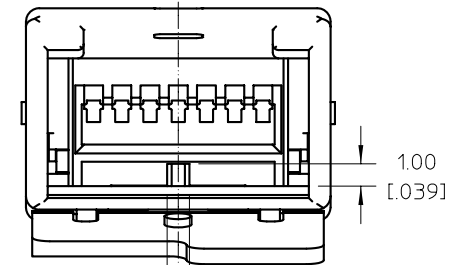

INFINIBAND KEY 3:1

INITIAL SALES DRAWING EC NO: UDT2001-1462 DRWN: DIRKERS 2001/06/15 CHKD: DIRKERS 2001/06/15 APPR: BRUSSELL 2001/06/19	QUALITY SYMBOLS ▽ = 0 ∇ = 0	GENERAL TOLERANCES (UNLESS SPECIFIED)		SCALE 6:1	DESIGN UNITS METRIC	THIRD ANGLE PROJECTION	REVISE ON CAD ONLY		
			mm	INCH	DIMENSION STYLE MM/IN		TITLE ADAPTER, HSSDC2 TO SFP		
		4 PLACES ± --- ± ---	3 PLACES ± --- ± .005	2 PLACES ± 0.13 ± ---	1 PLACE ± --- ± ---	DRAWN BY DIRKERS	DATE 2001/06/15	MATERIAL NO. SEE TABLE	
		ANGULAR ± 1/2°		DRAFT WHERE APPLICABLE		CHECKED BY DIRKERS	DATE 2001/06/15	DOCUMENT NO. SD-74720-101	SHEET NO. 2 OF 3
MUST REMAIN WITHIN DIMENSIONS				APPROVED BY	DATE	THIS DRAWING CONTAINS INFORMATION THAT IS PROPRIETARY TO MOLEX INCORPORATED AND SHOULD NOT BE USED WITHOUT WRITTEN PERMISSION			

6 5 4 3 2

Top View
Cutaway

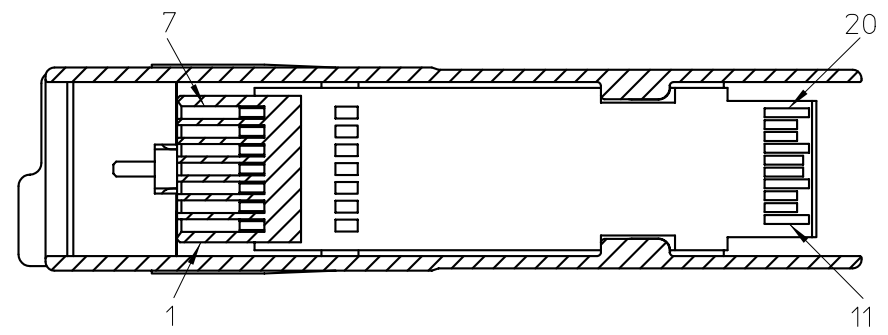

Bottom
View

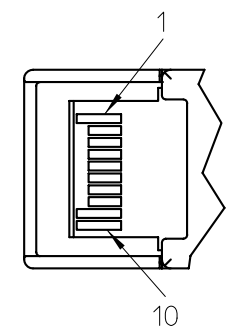

FIBER CHANNEL
WIRING
OPTION

7	Gnd
6	TD-
5	TD+
4	Gnd
3	RD+
2	RD-
1	Gnd

INFINIBAND
WIRING
OPTION

7	Gnd
6	TD+
5	TD-
4	Gnd
3	RD-
2	RD+
1	Gnd

Gnd T	20	1	Gnd T
TD-	19	2	Gnd T
TD+	18	3	Tx Disable
Gnd T	17	4	MOD-DEF(2)
VccT	16	5	MOD-DEF(1)
VccR	15	6	MOD-DEF(0)
Gnd R	14	7	Rate Select
RD+	13	8	LOS
RD-	12	9	Gnd R
Gnd R	11	10	Gnd R

INITIAL SALES DRAWING EC NO: UDT2001-1462 DRWN: DIRKERS 2001/06/15 CHKD: DIRKERS 2001/06/15 APPR: BRUSSELL 2001/06/19	QUALITY SYMBOLS ▽ = 0 ∇ = 0	GENERAL TOLERANCES (UNLESS SPECIFIED)		SCALE 2:1	DESIGN UNITS METRIC	THIRD ANGLE PROJECTION	REVISE ON CAD ONLY	
				DIMENSION STYLE MM/IN		TITLE ADAPTER, HSSDC2 TO SFP		
		4 PLACES ± --- ± ---		DRAWN BY DATE DIRKERS 2001/06/15		MOLLEX MOLEX INCORPORATED		
		3 PLACES ± --- ± .005		CHECKED BY DATE DIRKERS 2001/06/15				
2 PLACES ± 0.13 ± ---		APPROVED BY DATE		MATERIAL NO. SEE TABLE	DOCUMENT NO. SD-74720-101	SHEET NO. 3 OF 3		
1 PLACE ± --- ± ---		ANGULAR ±1/2°		THIS DRAWING CONTAINS INFORMATION THAT IS PROPRIETARY TO MOLEX INCORPORATED AND SHOULD NOT BE USED WITHOUT WRITTEN PERMISSION			A	
DRAFT WHERE APPLICABLE MUST REMAIN WITHIN DIMENSIONS								

5 4 3 2 1