

QT-Brightek PLCC Series

PLCC2 LED

Part No.: QBLP670-O-2897

2897: High Brightness Version

Product: QBLP670-O-2897	Date: November 04, 2019	Page 1 of 9
	Version# 1.3	

Table of Contents:

Introduction	3
Electrical / Optical Characteristic (Ta=25 °C)	4
Absolute Maximum Rating	4
Characteristic Curves.....	5
Solder Profile & Footprint.....	6
Packing	7
Labeling	8
Ordering Information	8
Revision History	9
Disclaimer	9

Introduction

Feature:

- Clear lens
- Package in tape and reel
- Ultra bright reflector type PLCC2 LED
- AlInGaP technology for O
- Viewing angle: 120 deg typ.

Description:

These ultra bright reflector type PLCC2 LEDs have a height profile of 1.90mm. Combination of high brightness output and robust package, these LEDs are ideal for architecture lighting, status indication, and industrial equipment lighting applications.

Application:

- Status indication
- Industrial equipment backlighting
- Architecture lighting

Certification & Compliance:

- TS16949
- ISO9001
- RoHS Compliant



Dimension:

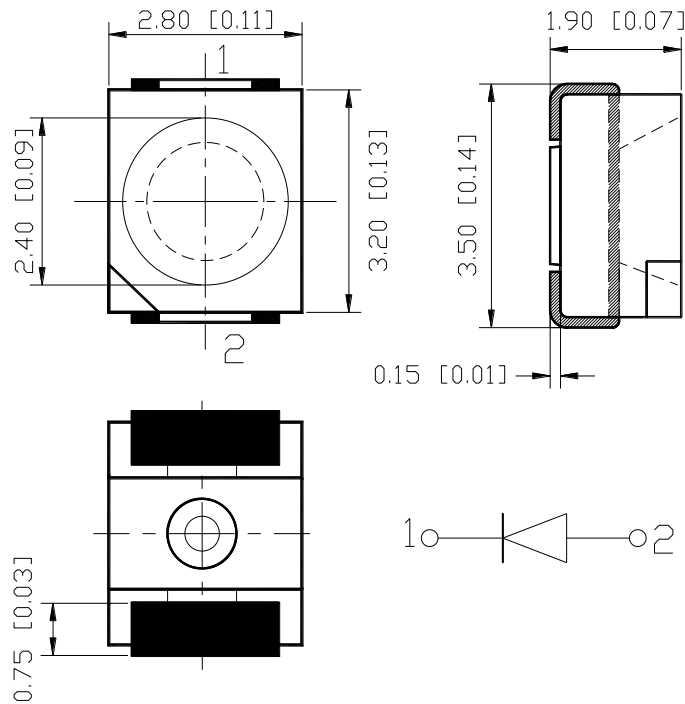

Units: mm / tolerance = +/-0.2mm

Electrical / Optical Characteristic (Ta=25 °C)

Product	Color	I _F (mA)	V _F (V)		λ _D (nm)			I _V (mcd)	
			Typ.	Max.	Min.	Typ.	Max.	Min.	Typ.
QBLP670-O-2897	Orange	20	2.0	2.5	600	605	610	500	740

Absolute Maximum Rating

Material	P _d (mW)	I _F (mA)	I _{FP} (mA)*	V _R (V)	T _{OP} (°C)	T _{ST} (°C)	T _{SO L} (°C)**
AllnGaP	75	30	125	5	-30 ~ +80	-40 ~ +85	260

*Duty 1/8 @ 1KHz

**IR Reflow for no more than 10 sec @ 260 °C

Forward Voltage V_F @ I_F=20mA

Bin	Min.	Max.	Unit
□	1.7	2.5	V

Luminous Intensity I_V @ I_F=20mA

Bin	Min.	Max.	Unit
Q	500	630	mcd
R	630	800	
S	800	1000	

Dominant Wavelength λ_D @ I_F=20mA

Bin	Min.	Max.	Unit
p	600	605	nm
q	605	610	

Characteristic Curves

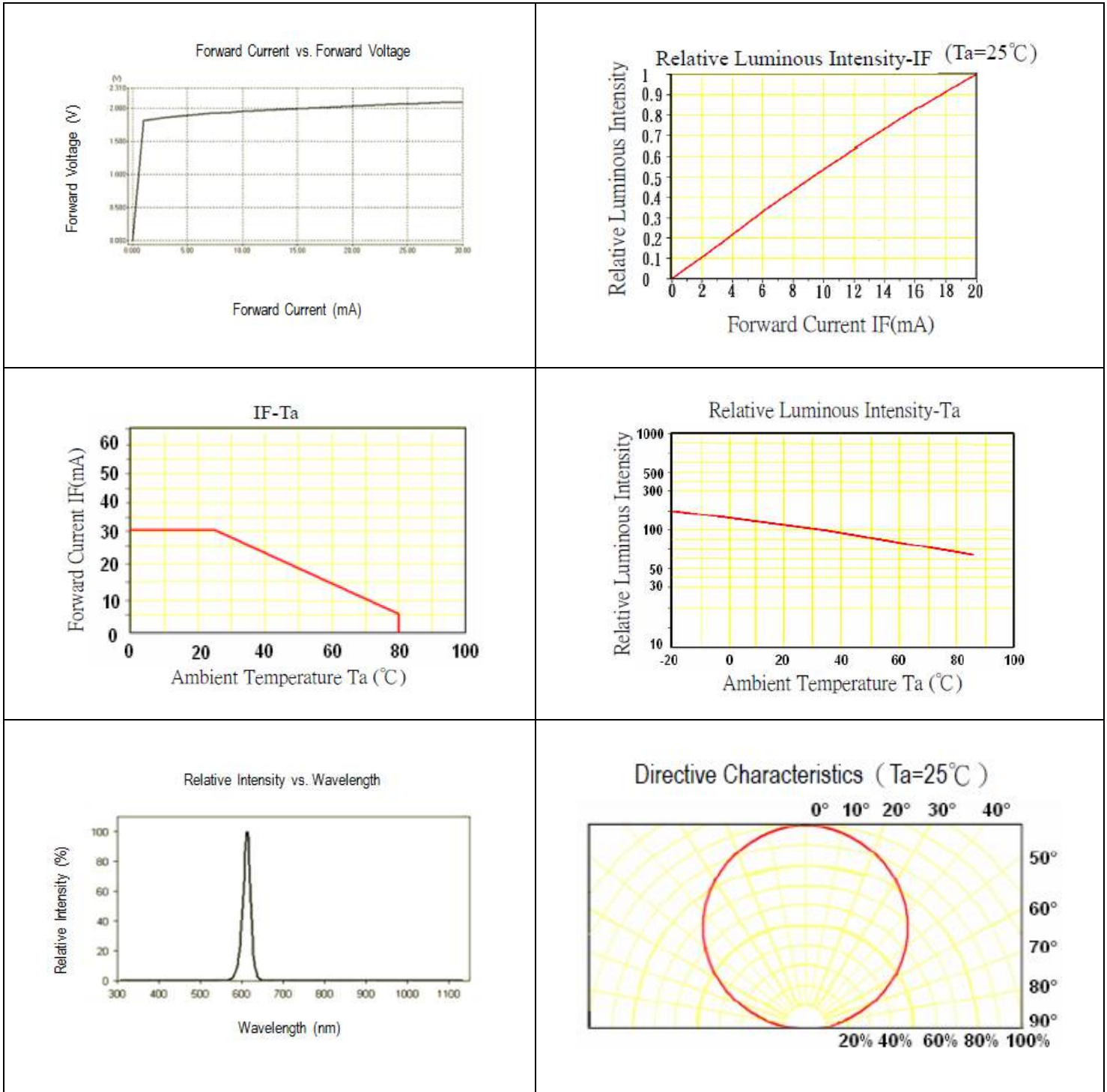

Solder Profile & Footprint

- Recommended tin solder specifications: melting temperature in the range of 178~192 °C
- The recommended reflow soldering profile is as follows (temperatures indicated are as measured on the surface of the LED resin):

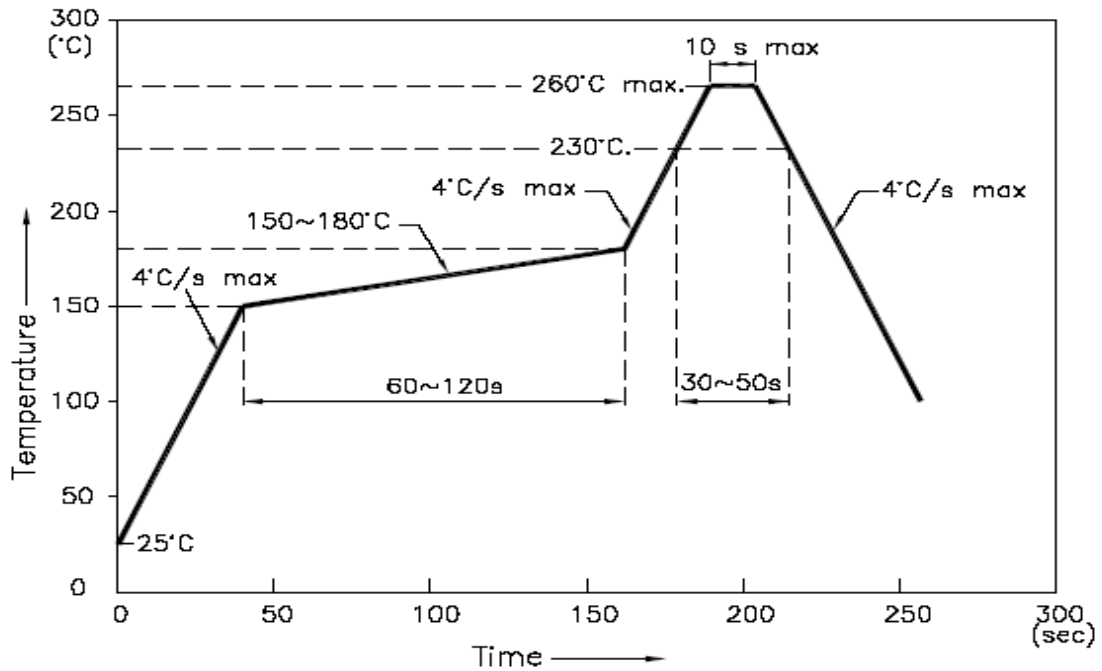

Recommended Pad Layout

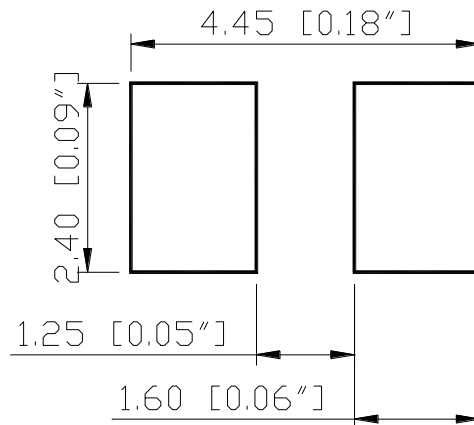

Units: mm

Tolerance: $\pm 0.1\text{mm}$

Packing

Reel Dimension:

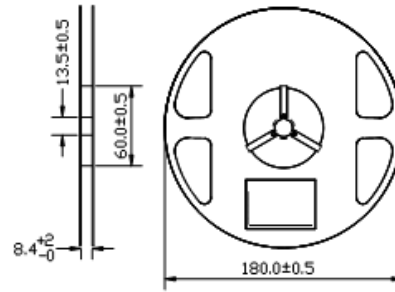

Unit: mm

Tape Dimension:

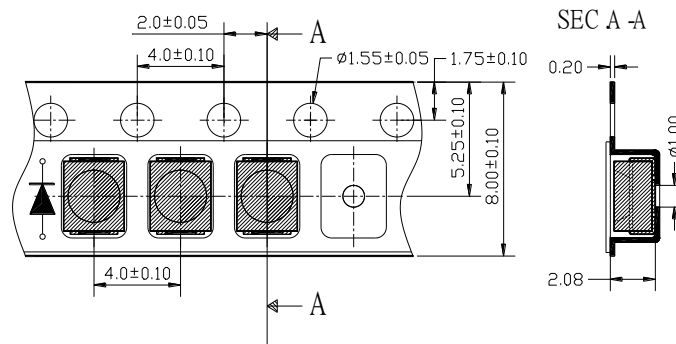

Unit: mm

Arrangement of Tape:

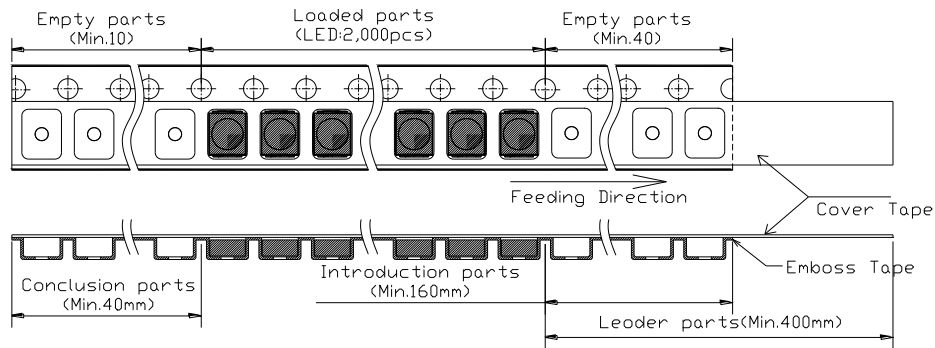

Packaging Specification:

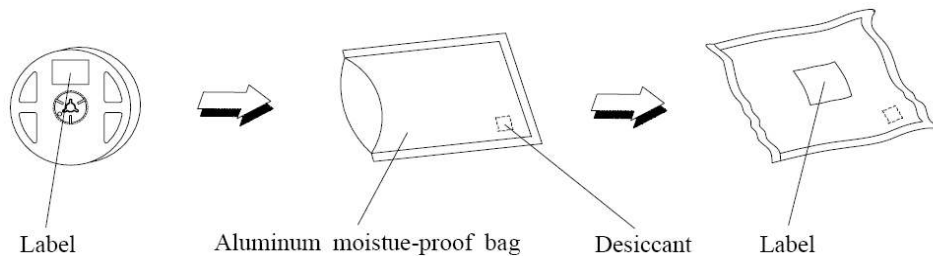

Labeling



Part No: _____

Customer P/N: _____

Item: _____

Q'ty: _____

Vf: _____

Iv: _____

WI: _____

Date: _____

Made in China

Ordering Information

Part #	Orderable Part #	Spec Range	Quantity per reel
QBLP670-O-2897	QBLP670-O-2897	Iv=740mcd typ. @ 20mA / $\lambda_D=600\text{nm to }610\text{nm}$	2,000 units

Revision History

Description:	Revision #	Revision Date
New Release of QBLP670-O (High Bright)	V1.0	05/24/2013
Information Update	V1.1	10/31/2014
Update minimum brightness	V1.2	03/12/2015
Update part number "High Bright" to "2897"	V1.3	11/04/2019

Disclaimer

QT-BRIGHTTEK reserves the right to make changes without further notice to any products herein to improve reliability, function or design. QT-BRIGHTTEK does not assume any liability arising out of the application or use of any product or circuit described herein; neither does it convey any license under its patent rights, nor the rights of others.

Life Support Policy

QT-BRIGHTTEK's products are not authorized for use as critical components in life support devices or systems without the express written approval of QT-BRIGHTTEK. As used herein:

1. Life support devices or systems are devices or systems which, (a) are intended for surgical implant into the body, or (b) support or sustain life, and (c) whose failure to perform when properly used in accordance with instructions for use provided in the labeling, can be reasonably expected to result in a significant injury of the user.
2. A critical component in any component of a life support device or system whose failure to perform can be reasonably expected to cause the failure of the life support device or system, or to affect its safety or effectiveness.