

PQ1CG3032FZ/ PQ1CG3032RZ

TO-220 Type Chopper Regulator

■ Features

1. Maximum switching current:3.5A
2. Built-in ON/OFF control function
3. Built-in soft start function to suppress overshoot of output voltage in power on sequence or ON/OFF control sequence
4. Built-in oscillation circuit
(Oscillation frequency:TYP. 150kHz)
5. Built-in overheat/overcurrent protection function
6. TO-220 package
7. Variable output voltage
(Output variable range: V_{ref} to $35V/-V_{ref}$ to $-30V$)
[Possible to select step-down output/inverting output according to external connection circuit]
8. **PQ1CG3032FZ**:Zigzag forming
PQ1CG3032RZ:Self-stand forming

■ Applications

1. CTV
2. Digital OA equipment
3. Facsimiles, printers and other OA equipment
4. Personal computers and amusement equipment

■ Absolute Maximum Ratings (Ta=25°C)

| Parameter | Symbol | Rating | Unit |
|------------------------------------|-----------|-------------|------|
| *1 Input voltage | V_{IN} | 40 | V |
| Output adjustment terminal voltage | V_{ADJ} | 7 | V |
| Dropout voltage | V_{I-O} | 41 | V |
| *2 Output-COM voltage | V_{OUT} | -1 | V |
| *3 ON/OFF control voltage | V_C | -0.3 to +40 | V |
| Switching current | I_{SW} | 3.5 | A |
| *4 Power dissipation | P_{D1} | 1.4 | W |
| | P_{D2} | 14 | W |
| *5 Junction temperature | T_j | 150 | °C |
| Operating temperature | T_{opr} | -20 to +80 | °C |
| Storage temperature | T_{stg} | -40 to +150 | °C |
| *6 Soldering temperature | T_{sol} | 260 | °C |

*1 Voltage between V_{IN} terminal and COM terminal

*2 Voltage between V_{OUT} terminal and COM terminal

*3 Voltage between ON/OFF control and COM terminal

*4 P_p :With infinite heat sink

*5 Over heat protection may operate at the condition $T_j=125^\circ\text{C}$ to 150°C

*6 For 10s

■ Outline Dimensions

(Unit : mm)

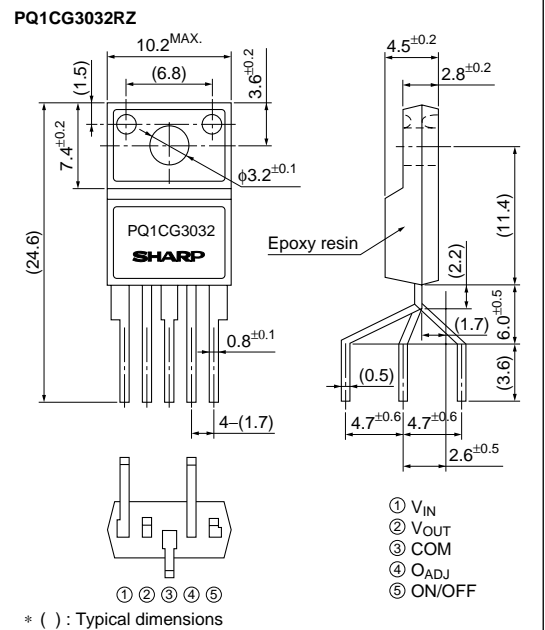
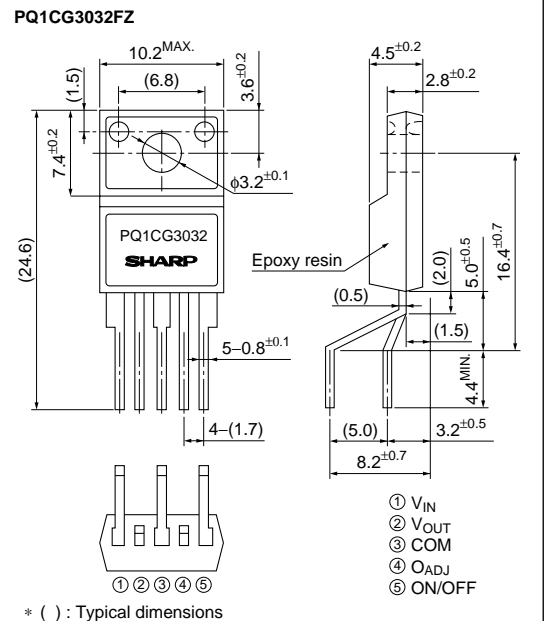

■ Electrical Characteristics (Unless otherwise specified, condition shall be $V_{IN}=12V$, $I_o=0.5A$, $V_o=5V$, ON-OFF terminals is open, $T_a=25^\circ C$)

| Parameter | Symbol | Conditions | MIN. | TYP. | MAX. | Unit |
|---|------------------|---|-------|-----------|-------|---------|
| Output saturation voltage | V_{SAT} | $I_{sw}=3A$ | — | 1.4 | 1.8 | V |
| Reference voltage | V_{ref} | — | 1.235 | 1.26 | 1.285 | V |
| Reference voltage temperature fluctuation | ΔV_{ref} | $T_j=0$ to $125^\circ C$ | — | ± 0.5 | — | % |
| Load regulation | $ R_{egL} $ | $I_o=0.5$ to $3A$ | — | 0.2 | 1.5 | % |
| Line regulation | $ R_{egI} $ | $V_{IN}=8$ to $35V$ | — | 1 | 2.5 | % |
| Efficiency | η | $I_o=3A$ | — | 80 | — | % |
| Oscillation frequency | f_o | — | 135 | 150 | 165 | kHz |
| Oscillation frequency temperature fluctuation | Δf_o | $T_j=0$ to $125^\circ C$ | — | ± 2 | — | % |
| Overcurrent detecting level | I_L | — | 3.6 | 4.7 | 5.8 | A |
| Charge current | I_{CHG} | ②, ④ terminals is open, ⑤ terminal | — | -10 | — | μA |
| Threshold input voltage | V_{THL} | Duty ratio=0%, ④ terminal=0V, ⑤ terminal | — | 1.3 | — | V |
| | V_{THH} | Duty ratio=100%, ④ terminal is open, ⑤ terminal | — | 2.3 | — | V |
| ON threshold voltage | $V_{TH(ON)}$ | ④ terminal=0V, ⑤ terminal | 0.7 | 0.8 | 0.9 | V |
| Stand-by current | I_{SD} | $V_{IN}=40V$, ⑤ terminal=0V | — | 140 | 400 | μA |
| Output OFF-state consumption current | I_{QS} | $V_{IN}=40V$, ⑤ terminal=0.9V | — | 8 | 16 | mA |

Fig.1 Standard Test Circuit

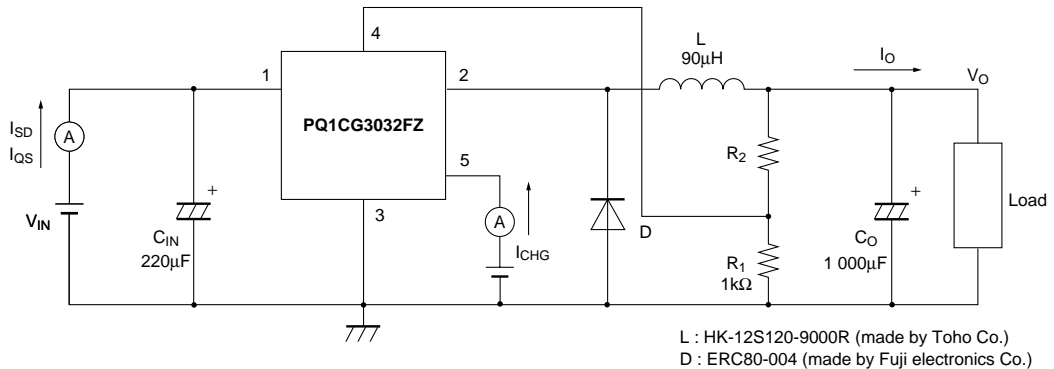
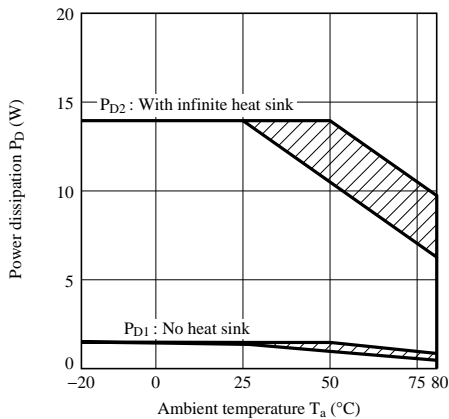

Fig.2 Power Dissipation vs. Ambient Temperature



Note) Oblique line prtion:Overheat protection may operate in this area

Fig.3 Overcurrent Protection Characteristics (Typical Value)

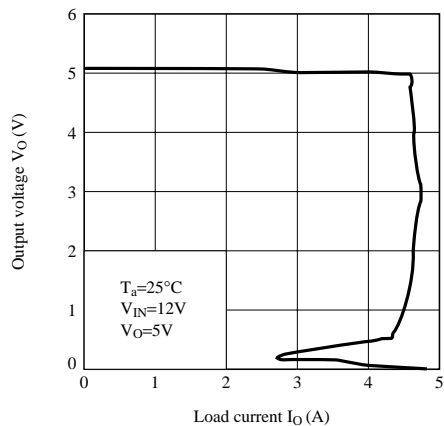

Fig.4 Efficiency vs. Input Voltage

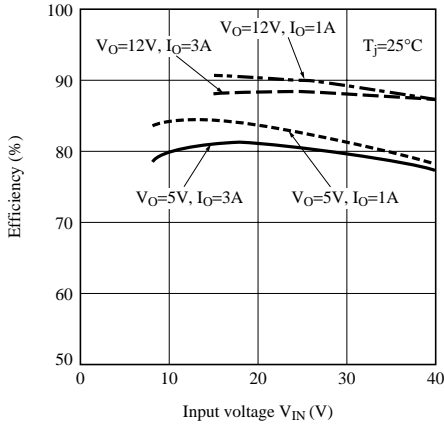

Fig.5 Output Saturation Voltage vs. Switching Current

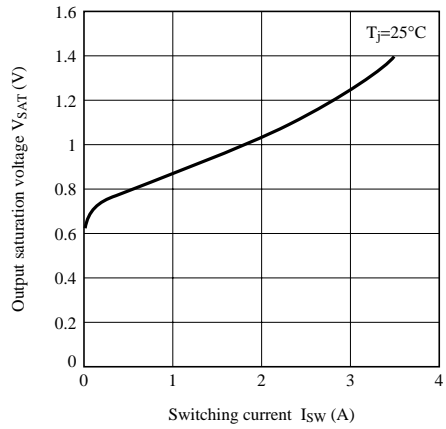

Fig.6 Stand by Current vs. Input Voltage

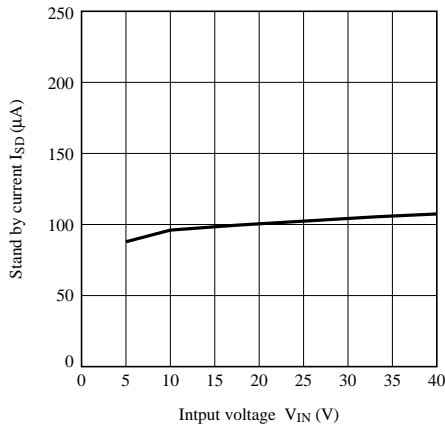

Fig.7 Reference Voltage Fluctuation vs. Junction Temperature

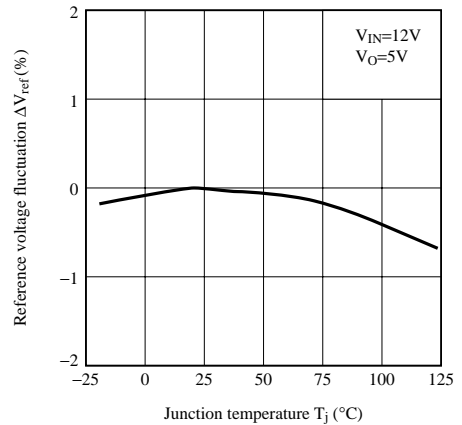

Fig.8 Load Regulation vs. Output Current

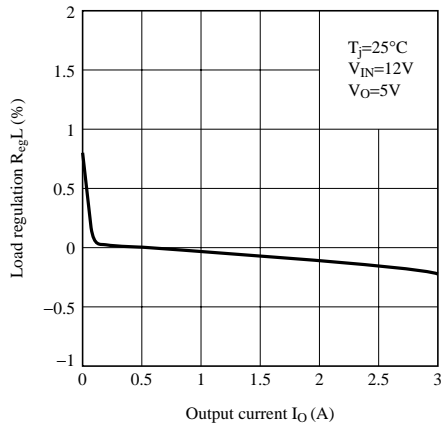

Fig.9 Line Regulation vs. Input Voltage

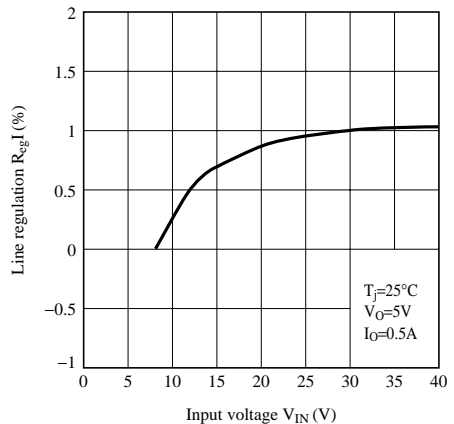

Fig.10 Oscillation Frequency Fluctuation vs. Junction Temperature

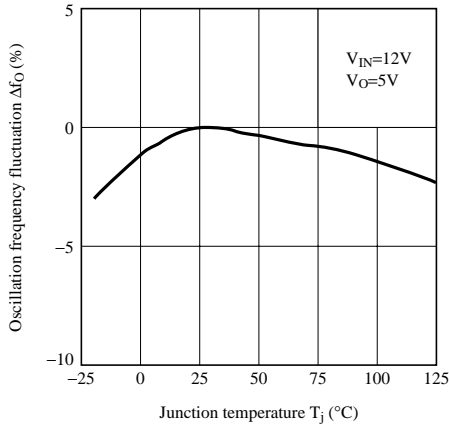

Fig.11 Overcurrent Detection Level Fluctuation vs. Junction Temperature

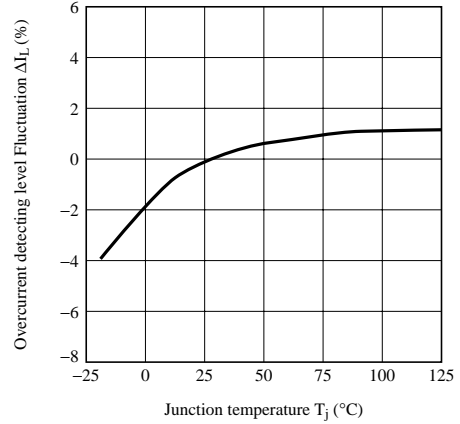

Fig.12 Threshold Voltage vs. Junction Temperature

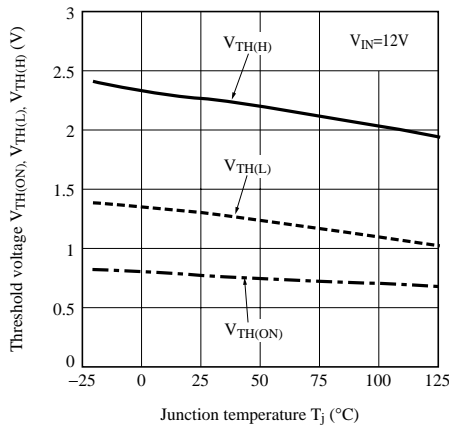

Fig.13 Operating Consumption Current vs. Input Voltage

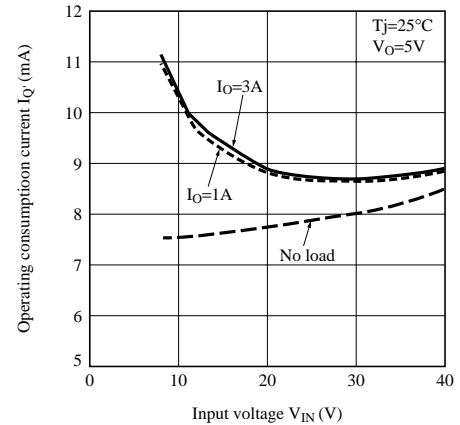

Fig.14 Block Diagram

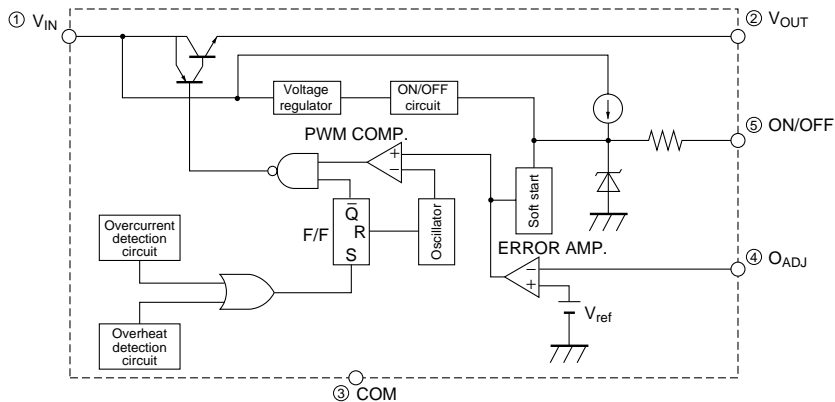

Fig.15 Step Down Type Circuit Diagram

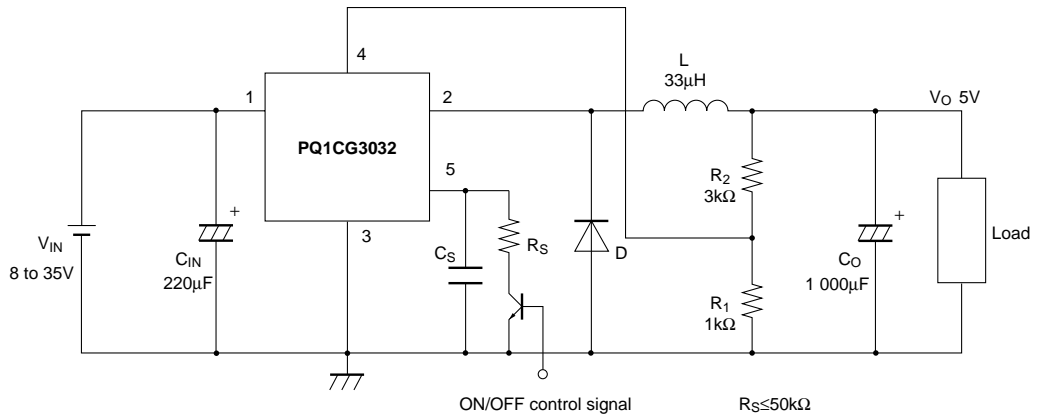
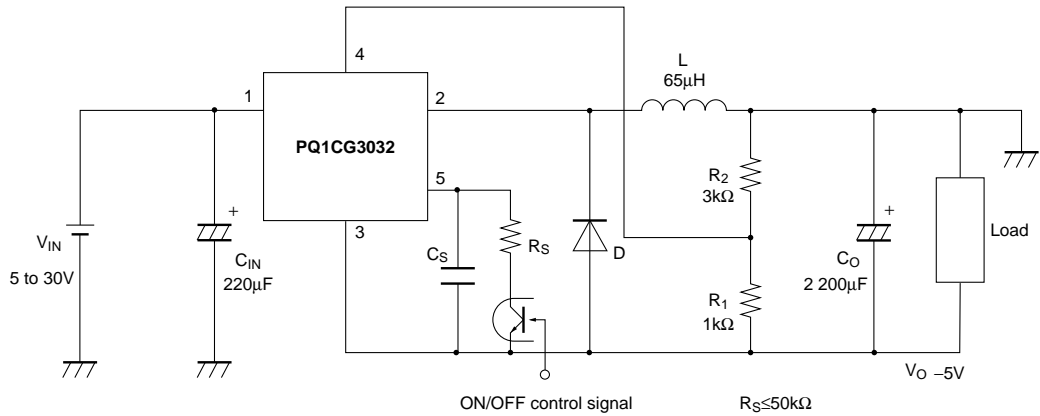
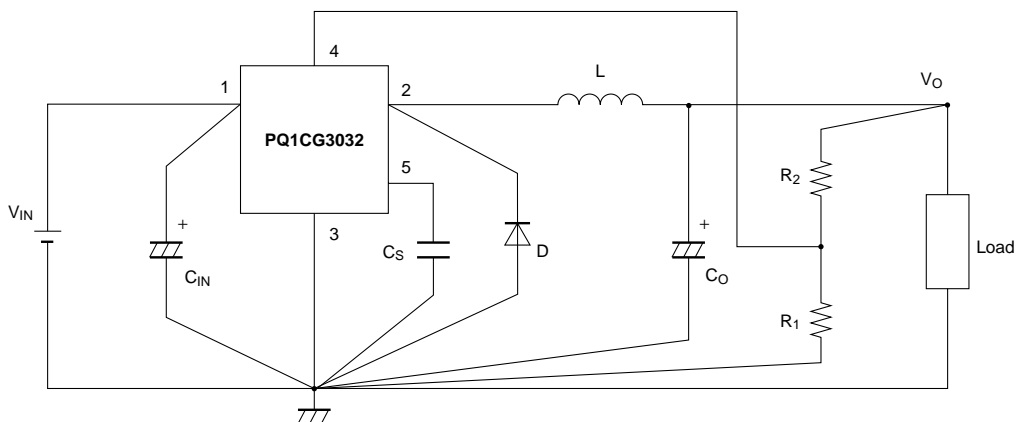

Fig.16 Polarity Inversion Type Circuit Diagram



■ Precautions for Use



1. External connection

- (1) Wiring condition is very important. Noise associated with wiring inductance may cause problems.

For minimizing inductance, it is recommended to design the thick and short pattern (between large current diodes, input/output capacitors, and terminal 1,2.) Single-point grounding (as indicated) should be used for best results.

- (2) High switching speed and low forward voltage type schottky barrier diode should be recommended for the catch-diode D because it affects the efficiency. Please select the diode which the current rating is at least 1.2 times greater than maximum switching current.
- (3) The output ripple voltage is highly influenced by ESR (Equivalent Series Resistor) of output capacitor, and can be minimized by selecting Low ESR capacitor.
- (4) An inductor should not be operated beyond its maximum rated current so that it may not saturate.
- (5) When voltage that is higher than V_{IN} ①, is applied to V_{OUT} ②, there is the case that the device is broken. Especially, in case V_{IN} ① is shorted to GND in normal condition, there is the case that the device is broken since the charged electric charge in output capacitor (C_O) flows into input side. In such case a schottky barrier diode or a silicon diode shall be recommended to connect as the following circuit.

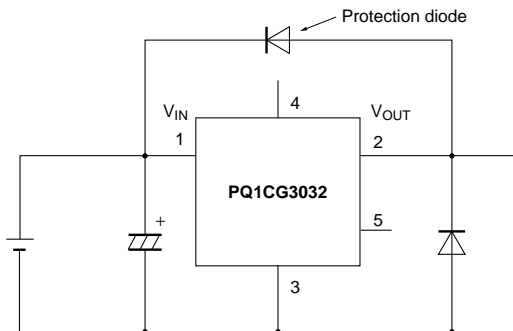

■ ON/OFF Control Terminal

1. In the following circuit, when ON/OFF control terminal ⑤ becomes low by switching transistor T_r on, output voltage may be turned OFF and the device becomes stand-by mode. Dissipation current at stand-by mode becomes Max.400 μ A.

2. Soft start

When capacitor C_s is attached, output pulse gradually expanded and output voltage will start softly.

3. ON/OFF control with soft startup

For ON/OFF control with capacitor C_s , be careful not to destroy a transistor T_r by discharge current from C_s , adding a resistor restricting discharge current of C_s .

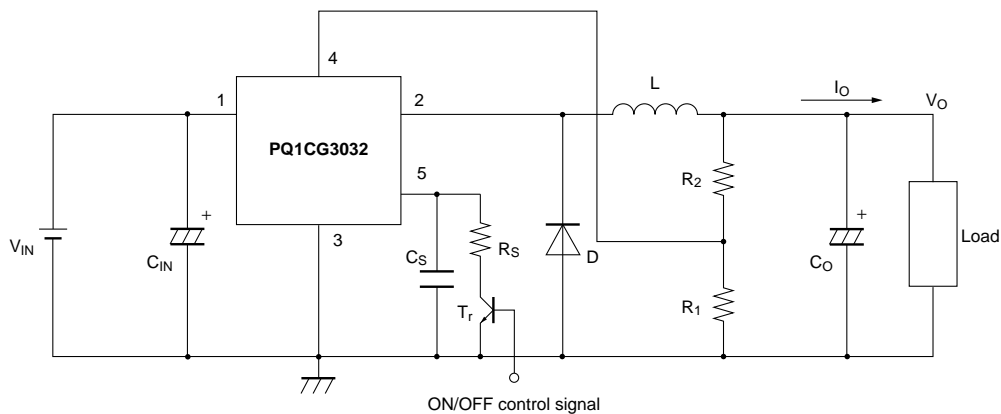

■ ON-OFF Terminal Voltage vs. Time

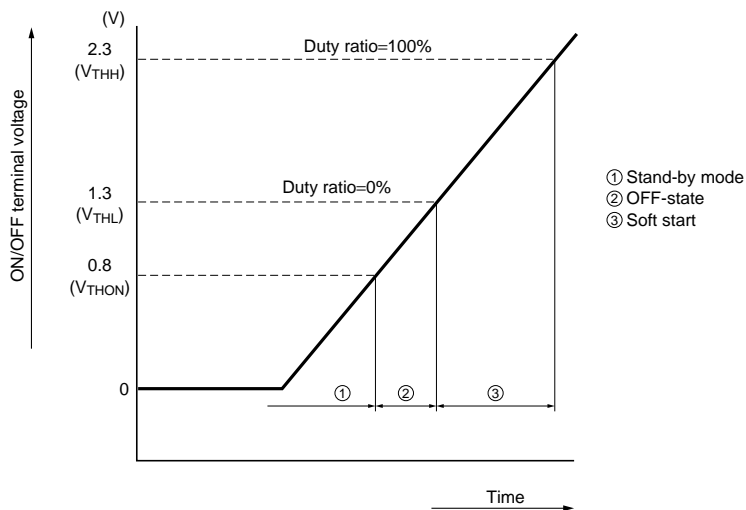

NOTICE

- The circuit application examples in this publication are provided to explain representative applications of SHARP devices and are not intended to guarantee any circuit design or license any intellectual property rights. SHARP takes no responsibility for any problems related to any intellectual property right of a third party resulting from the use of SHARP's devices.
- Contact SHARP in order to obtain the latest device specification sheets before using any SHARP device. SHARP reserves the right to make changes in the specifications, characteristics, data, materials, structure, and other contents described herein at any time without notice in order to improve design or reliability. Manufacturing locations are also subject to change without notice.
- Observe the following points when using any devices in this publication. SHARP takes no responsibility for damage caused by improper use of the devices which does not meet the conditions and absolute maximum ratings to be used specified in the relevant specification sheet nor meet the following conditions:
 - (i) The devices in this publication are designed for use in general electronic equipment designs such as:
 - Personal computers
 - Office automation equipment
 - Telecommunication equipment [terminal]
 - Test and measurement equipment
 - Industrial control
 - Audio visual equipment
 - Consumer electronics
 - (ii) Measures such as fail-safe function and redundant design should be taken to ensure reliability and safety when SHARP devices are used for or in connection with equipment that requires higher reliability such as:
 - Transportation control and safety equipment (i.e., aircraft, trains, automobiles, etc.)
 - Traffic signals
 - Gas leakage sensor breakers
 - Alarm equipment
 - Various safety devices, etc.
 - (iii) SHARP devices shall not be used for or in connection with equipment that requires an extremely high level of reliability and safety such as:
 - Space applications
 - Telecommunication equipment [trunk lines]
 - Nuclear power control equipment
 - Medical and other life support equipment (e.g., scuba).
- Contact a SHARP representative in advance when intending to use SHARP devices for any "specific" applications other than those recommended by SHARP or when it is unclear which category mentioned above controls the intended use.
- If the SHARP devices listed in this publication fall within the scope of strategic products described in the Foreign Exchange and Foreign Trade Control Law of Japan, it is necessary to obtain approval to export such SHARP devices.
- This publication is the proprietary product of SHARP and is copyrighted, with all rights reserved. Under the copyright laws, no part of this publication may be reproduced or transmitted in any form or by any means, electronic or mechanical, for any purpose, in whole or in part, without the express written permission of SHARP. Express written permission is also required before any use of this publication may be made by a third party.
- Contact and consult with a SHARP representative if there are any questions about the contents of this publication.