

© 2019 TE Connectivity. All Rights Reserved.

REVISIONS				
P	LTR	DESCRIPTION	DATE	APVD
	A	RELEASE TO PRODUCTION	09DEC2019	AY PS

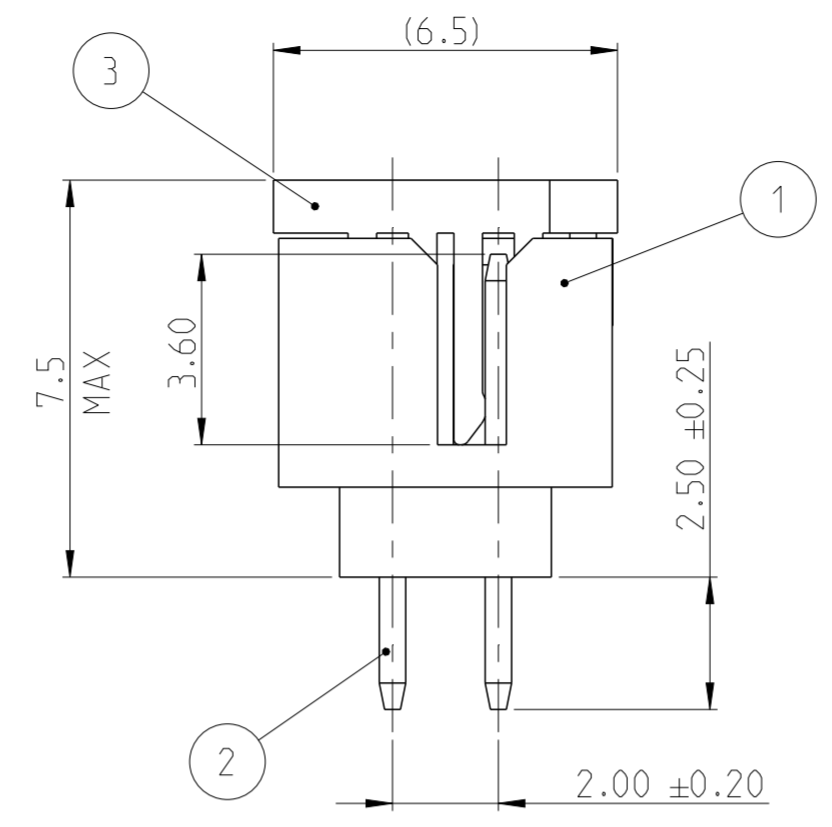

NOTES:  
 1. MATERIAL  
 HOUSING & P&P CAP : HIGH TEMPERATURE THERMOPLASTIC, UL94-V0; COLOR- BLACK  
 POST : COPPER ALLOY  
 FINISH :  
 MATING SIDE: MIN. 0.38 μm GOLD OVER NICKEL UNDER PLATING.  
 SOLDER SIDE: MIN. 2.0 μm TIN OVER NICKEL UNDER PLATING.  
 2. PACKAGING: TAPE AND REEL (WITH PICK AND PLACE CAP)  
 3. TOLERANCE NOT CUMULATIVE.

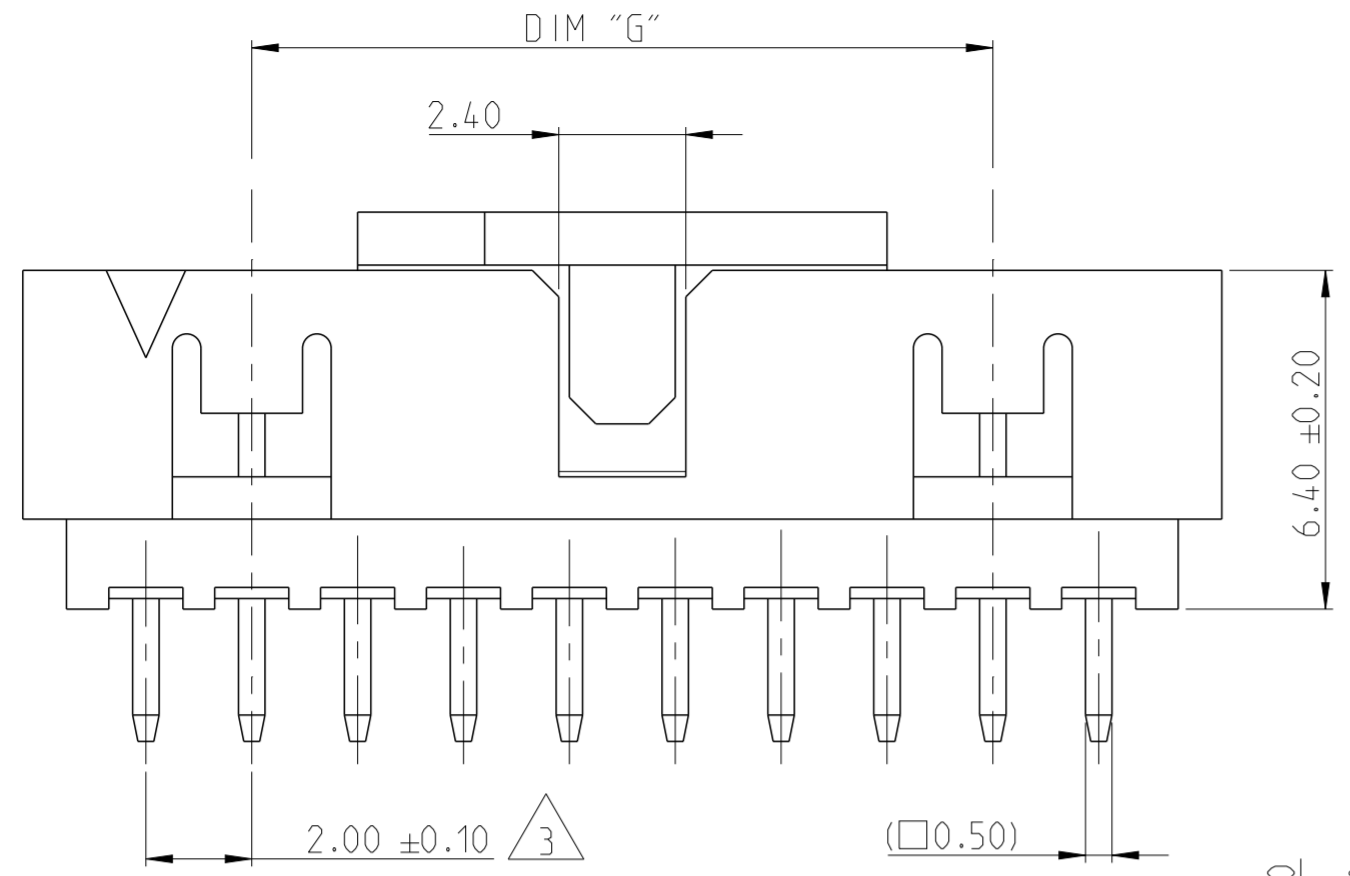
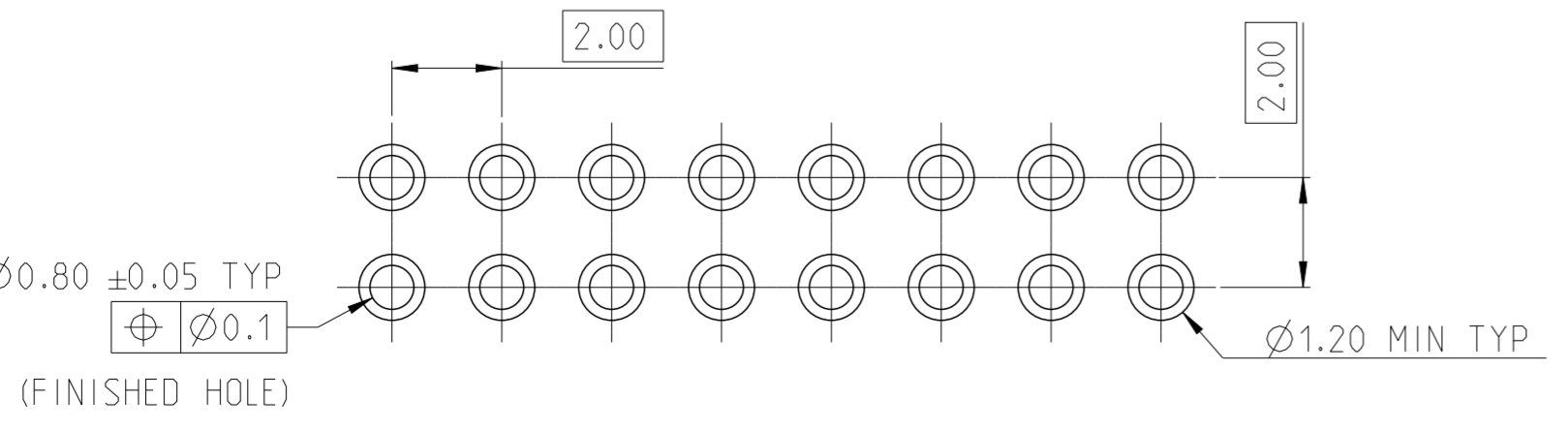
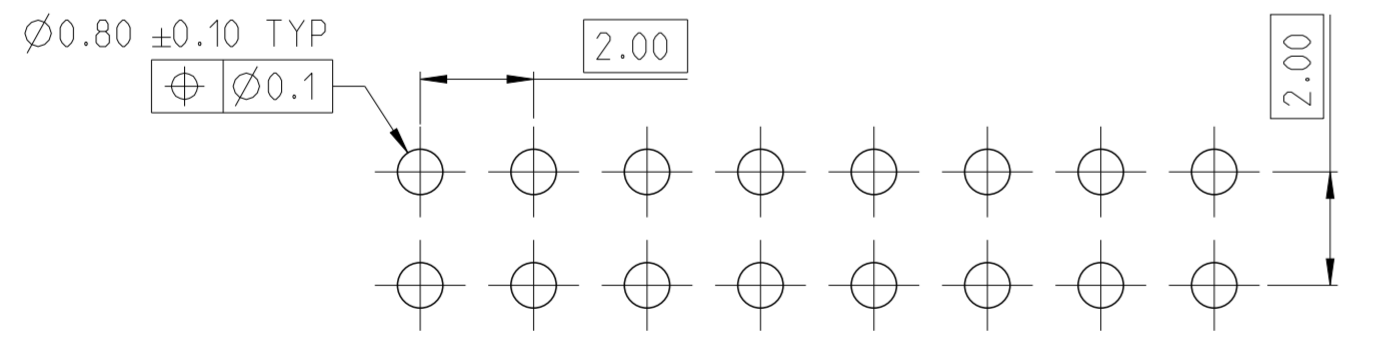
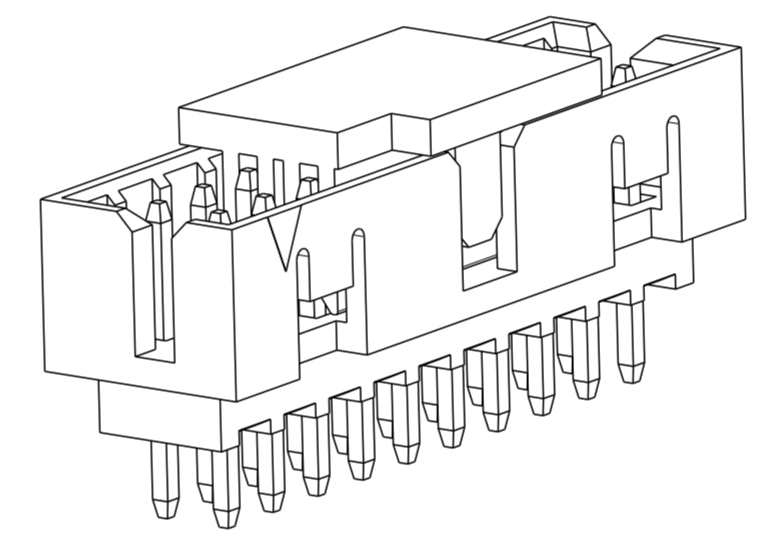
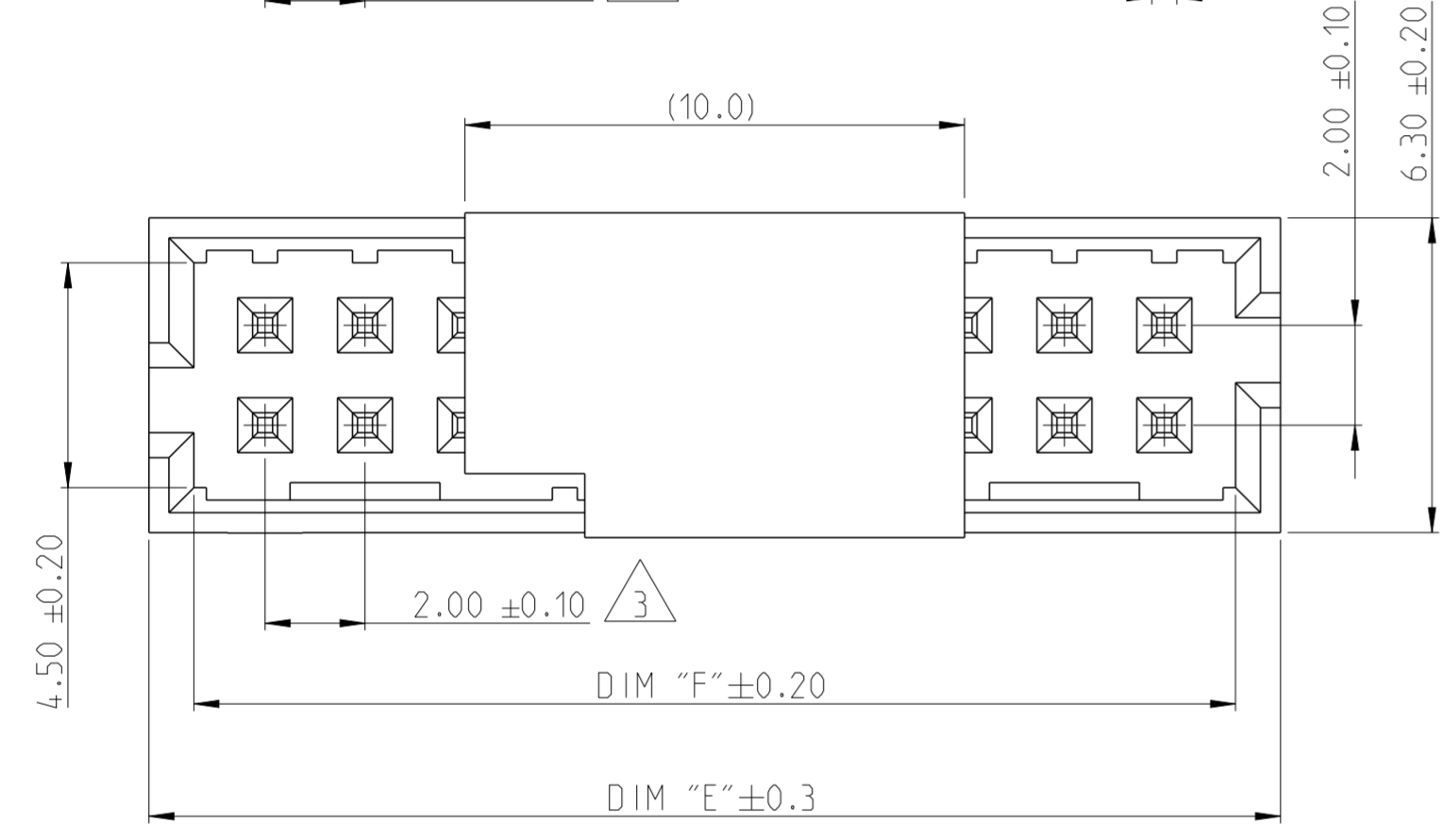

2-2842307-0 AS SHOWN

44	50.85	52.65	50	5-2842307-0
38	44.85	46.65	44	4-2842307-4
34	40.85	42.65	40	4-2842307-0
28	34.85	36.65	34	3-2842307-4
24	30.85	32.65	30	3-2842307-0
20	26.85	28.65	26	2-2842307-6
18	24.85	26.65	24	2-2842307-4
14	20.85	22.65	20	2-2842307-0
10	16.85	18.65	16	1-2842307-6
8	14.85	16.65	14	1-2842307-4
DIM "G"	DIM "F"	DIM "E"	POS.	TE PN.

THIS DRAWING IS A CONTROLLED DOCUMENT.		DWN ANKIT YADAV 12NOV2019	TE Connectivity	
DIMENSIONS: mm		CHK KARTHIK JK 25NOV2019		
TOLERANCES UNLESS OTHERWISE SPECIFIED:		APVD PRASHANTH S. 27NOV2019	NAME AMPMODU 2mm SHROUDED HEADER, DUAL ROW, VERTICAL TH. 0.38 Au, T/R, WITH PICK AND PLACE CAP	
0 PLC ±	1 PLC ±	PRODUCT SPEC 108-64040	SIZE A2	CAGE CODE 00779
2 PLC ±0.25	3 PLC ±	APPLICATION SPEC 114-32259	DRAWING NO C-2842307	RESTRICTED TO -
4 PLC ±	ANGLES ±2°	WEIGHT -	SCALE 5:1	SHEET 1 OF 1
MATERIAL SEE NOTES		CUSTOMER DRAWING	REV A	
FINISH -				

PICK AND PLACE CAP	3
CONTACT PIN	2
HOUSING	1
DESCRIPTION	ITEM NO.