

THIS DRAWING IS UNPUBLISHED. RELEASED FOR PUBLICATION
 © COPYRIGHT - By - ALL RIGHTS RESERVED.

LOC	DIST	REVISIONS			
P	LTR	DESCRIPTION	DATE	DWN	APVD
AF	50	A2	ECR-13-016672	25OCT13	PKS RRP

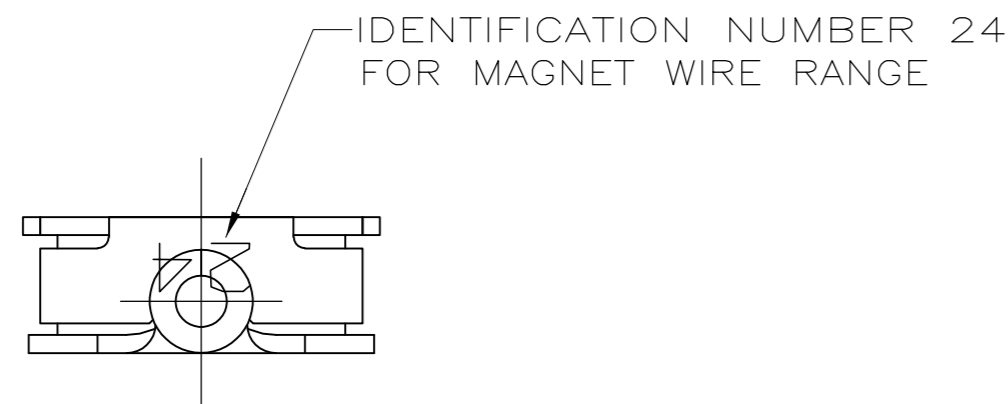

- 1 SUPPLIED IN LOOSE PIECE
- 2 SLOT ACCEPTS 0.86-1.15mm [#19.5-#17] AWG COPPER MAGNET WIRE. 2 WIRES OF THE SAME SIZE MAX PER SLOT.
- 3 VARNISH RESIST OVER TIN

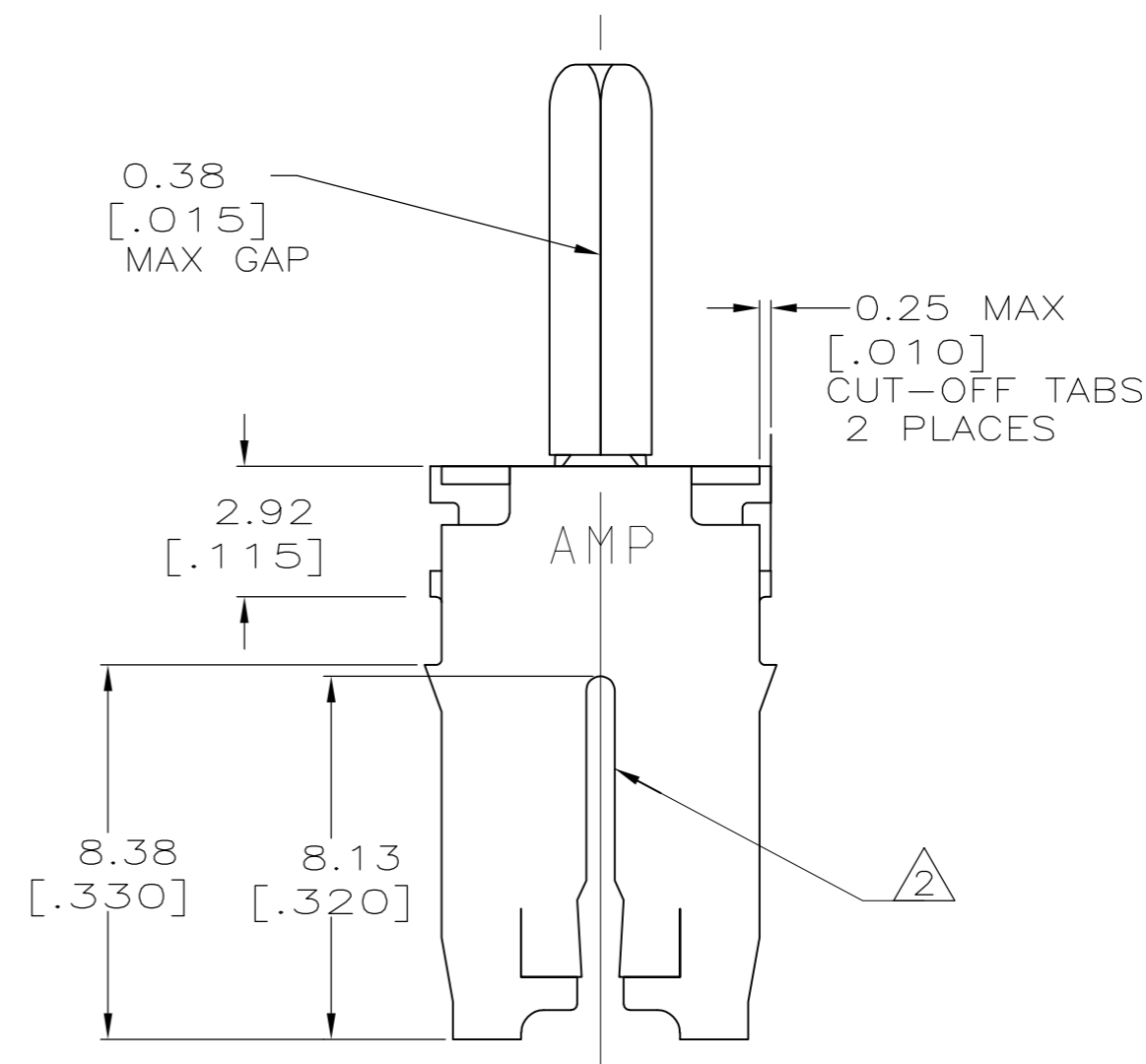
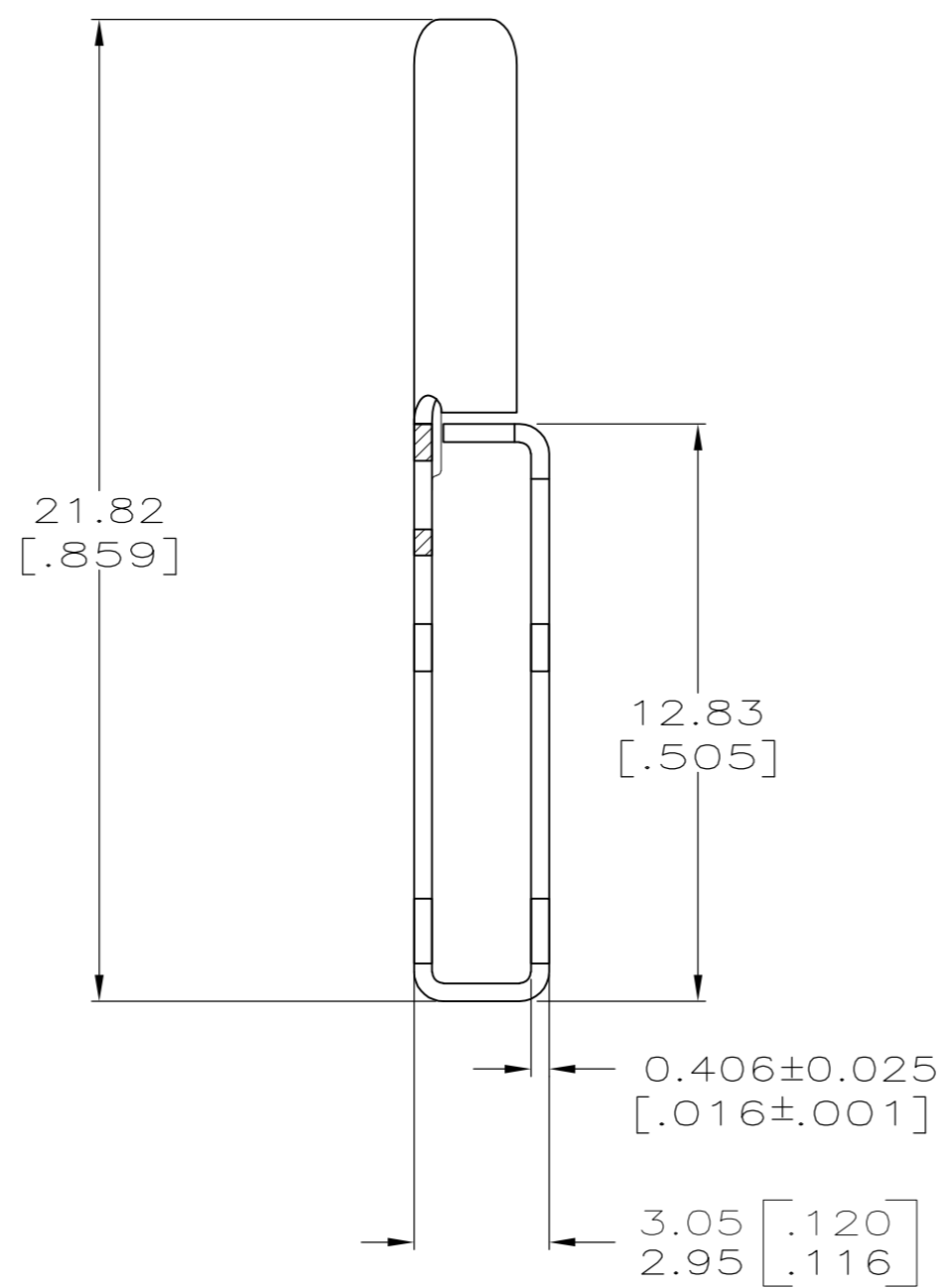
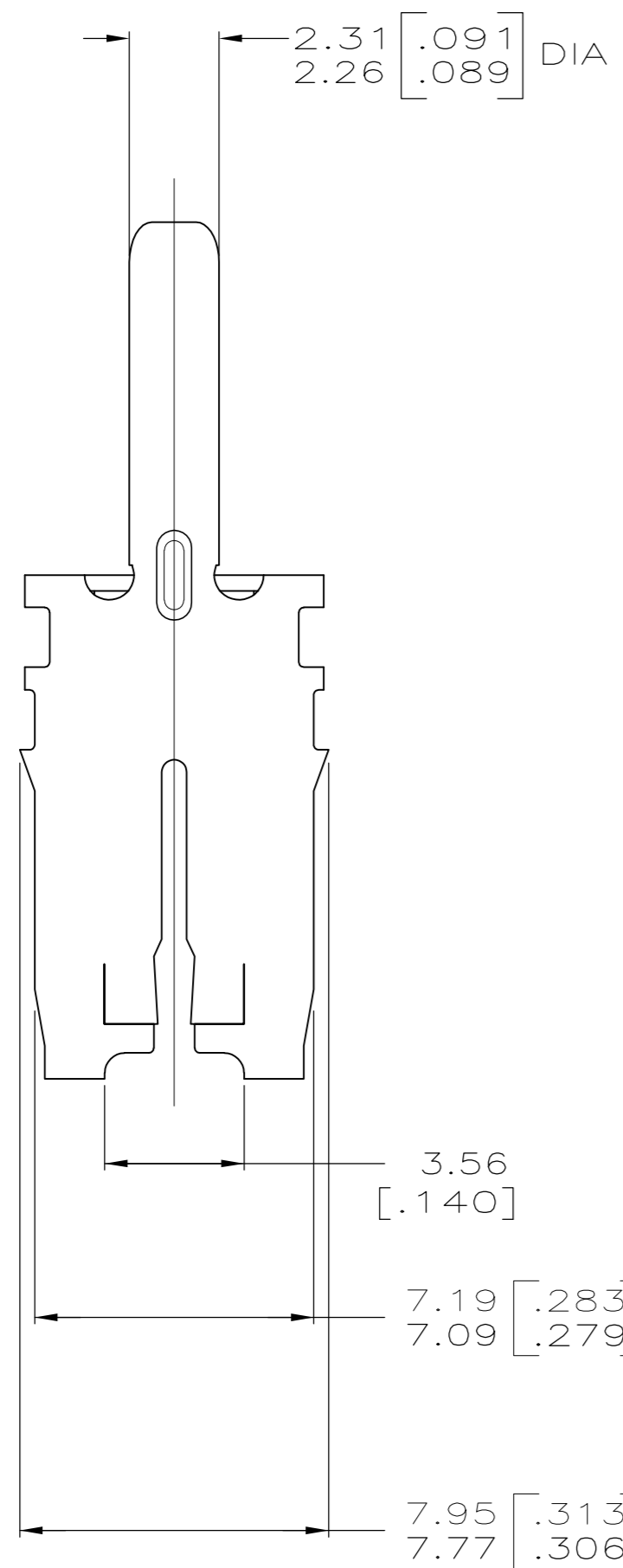

1742404-1
PART NUMBER

THIS DRAWING IS A CONTROLLED DOCUMENT.		DWN JR RUTH 07MAR06																							
DIMENSIONS: INCHES		CHK K RANDOLPH 07MAR06																							
TOLERANCES UNLESS OTHERWISE SPECIFIED:		APVD K RANDOLPH 07MAR06	NAME K RANDOLPH																						
<table border="1"> <tr><td>0 PLC</td><td>±</td><td>-</td></tr> <tr><td>1 PLC</td><td>±</td><td>-</td></tr> <tr><td>2 PLC</td><td>±</td><td>0.25[.010]</td></tr> <tr><td>3 PLC</td><td>±</td><td>-</td></tr> <tr><td>4 PLC</td><td>±</td><td>-</td></tr> <tr><td>ANGLES</td><td>±</td><td>-</td></tr> <tr><td>FINISH</td><td>-</td><td>3</td></tr> </table>		0 PLC	±	-	1 PLC	±	-	2 PLC	±	0.25[.010]	3 PLC	±	-	4 PLC	±	-	ANGLES	±	-	FINISH	-	3	PRODUCT SPEC 108-2053	PIN, 2.29[.090] DIA, 500 SERIES MAG-MATE	
0 PLC	±	-																							
1 PLC	±	-																							
2 PLC	±	0.25[.010]																							
3 PLC	±	-																							
4 PLC	±	-																							
ANGLES	±	-																							
FINISH	-	3																							
MATERIAL BRASS		APPLICATION SPEC 114-2066	SIZE A2	CAGE CODE 00779	DRAWING NO 1742404																				
		WEIGHT -	RESTRICTED TO -	SCALE 6:1	SHEET 1 of 1																				
		CUSTOMER DRAWING	REV A2																						