

# OV10626 HD HDR product brief



Day (Non-HDR)



Day (HDR)



Night (Non-HDR)



Night (HDR)

## Redefined Imaging Performance for Rear and Surround View Automotive Vision Systems



available in  
a lead-free  
package

The OV10626 is a single-chip, high-performance camera solution for rear and surround view automotive vision systems. The AutoVision sensor leverages advanced imaging concepts to deliver exceptional high dynamic range (HDR) while maintaining excellent low-light sensitivity.

The OV10626 supports 1/3.7-inch NTSC analog (648x488 resolution) and 1/3.2-inch WVGA digital (752x548 resolution) outputs. The sensor's color HDR of up to 120 dB and low-light sensitivity of 16 V/lux-sec ensures that clear, high-quality images are captured, even in extremely challenging lighting conditions.

The OV10626 also features a dual overlay function. This feature may be used for reference frames and guiding systems for backup and parking assist systems.

The compact OV10626 is packaged in OmniVision's proprietary AutoVision chip-scale package (a-CSP™), which is the industry's most efficient package available. The OV10626 will be qualified to AEC-Q100 Grade-2 Specifications (-40°C to +105°C).

Find out more at [www.ovt.com](http://www.ovt.com).



## Applications

- Automotive
  - 360° surround view
  - automotive machine vision
  - lane departure warning
  - traffic sign recognition
  - automatic high beam control
  - object detection
- pedestrian detection
- rear view camera
- blind spot detection
- mirror replacement
- occupant sensor
- night vision

## Product Features

- support for image size:
  - WVGA
  - VGA
  - QVGA, and any cropped size
- high dynamic range
- high sensitivity
- safety features
- low power consumption
- image sensor processor functions:
  - automatic exposure/gain control
  - automatic white balance control
  - lens correction
  - defective pixel cancellation
  - HDR combination and tone mapping
  - automatic black level correction
- supported output formats:
  - YUV, RAW, CCIR656
- horizontal and vertical sub-sampling
- serial camera control bus (SCCB) for register programming
- SPI master for overlay and loading settings
- external frame synchronization capability
- 50/60 Hz flicker cancellation
- parallel 16-bit DVP output
- NTSC with overlay and analog output
- embedded temperature sensor
- one time programmable (OTP) memory

# OV10626

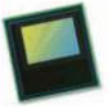

## Ordering Information

- OV10626-N02V-PE-Z** (color, lead-free)  
102-pin a-CSP™, rev 1E, 50°C packed in tray with protective film)

## Technical Specifications

- active array size:** 752 x 548
- maximum image transfer rate:** 60 fps full resolution
- power supply:**
  - core: 1.425 - 1.575V
  - analog: 3.14 - 3.47V
  - I/O: 1.7 - 3.47V
- power requirements:**
  - active: 410 mW typical @ 3.3V AVDD, 1.5V DVDD, and 1.8V DOVDD
  - standby: 260 μW typical @ 3.3V AVDD, 1.5V DVDD, and 1.8V DOVDD
- temperature range:**
  - operating: -40°C to +105°C sensor ambient temperature and -40°C to +125°C junction temperature (operating sensor junction temperatures above +60°C may result in degraded image quality)
- output interfaces:** 16-bit parallel DVP, analog NTSC (single end and differential)
- output formats:** up to 20-bit combined RAW, separated 8-/10-bit RAW, 8-/10-bit YUV422
- lens size:**
  - VGA and NTSC: 1/3.7"
  - WVGA: 1/3.2"
- lens chief ray angle:** 9°
- scan mode:** progressive
- shutter:** rolling shutter
- pixel size:** 6 μm x 6 μm
- image area:** 4608 μm x 3384 μm

## Functional Block Diagram

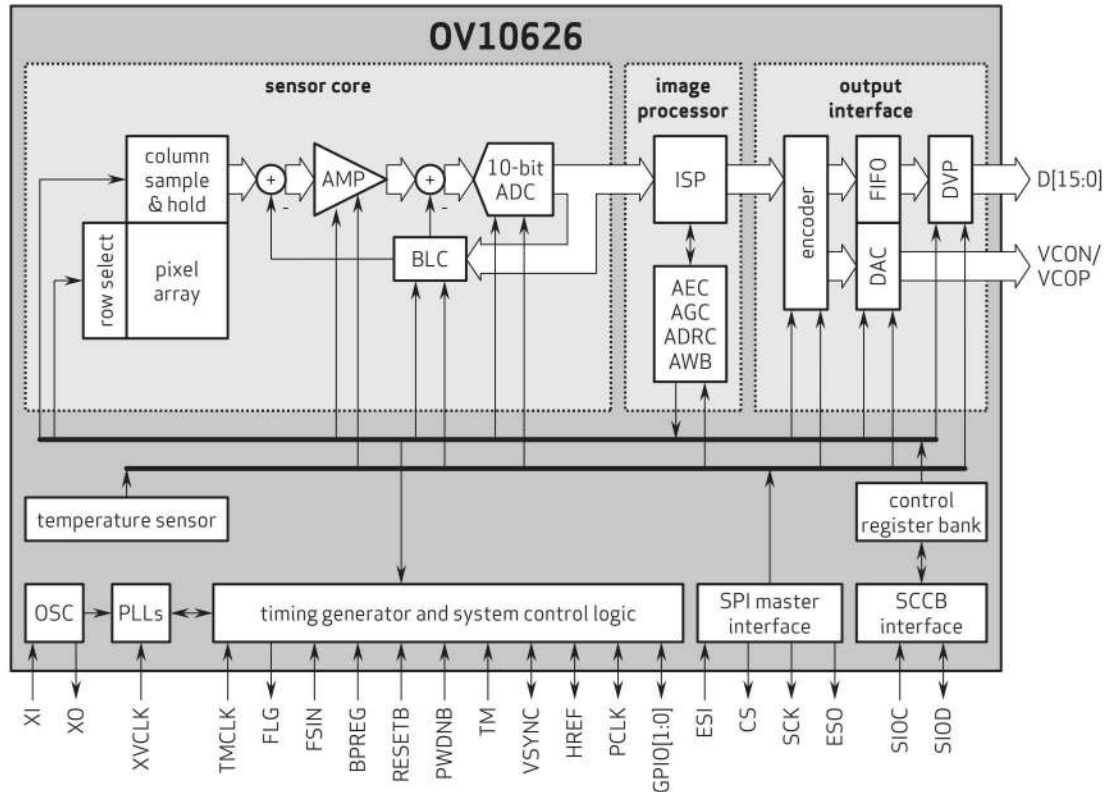

4275 Burton Drive  
Santa Clara, CA 95054  
USA

Tel: +1 408 567 3000  
Fax: +1 408 567 3001  
www.ovt.com

OmniVision reserves the right to make changes to their products or to discontinue any product or service without further notice. OmniVision and the OmniVision logo are registered trademarks of OmniVision Technologies, Inc. a-CSP is a trademark of OmniVision Technologies, Inc. All other trademarks are the property of their respective owners.



**OmniVision**