

**FEATURES**

- 600ps max. propagation delay
- Extended 100E VEE range of -4.2V to -5.5V
- True and complementary outputs
- OR/NOR function outputs
- Fully compatible with Industry standard 10KH, 100K I/O levels
- Internal 75KΩ input pulldown resistors
- Fully compatible with Motorola MC10E/100E107
- Available in 28-pin PLCC package

**DESCRIPTION**

The SY10/100E107 offer five 2-input XOR/XNOR gates and are designed for use in new, high- performance ECL systems.

The E107 also features a function output, F, which is the OR of all five XOR gate outputs, while  $\bar{F}$  is the NOR. Both true and complementary outputs are provided.

**BLOCK DIAGRAM**

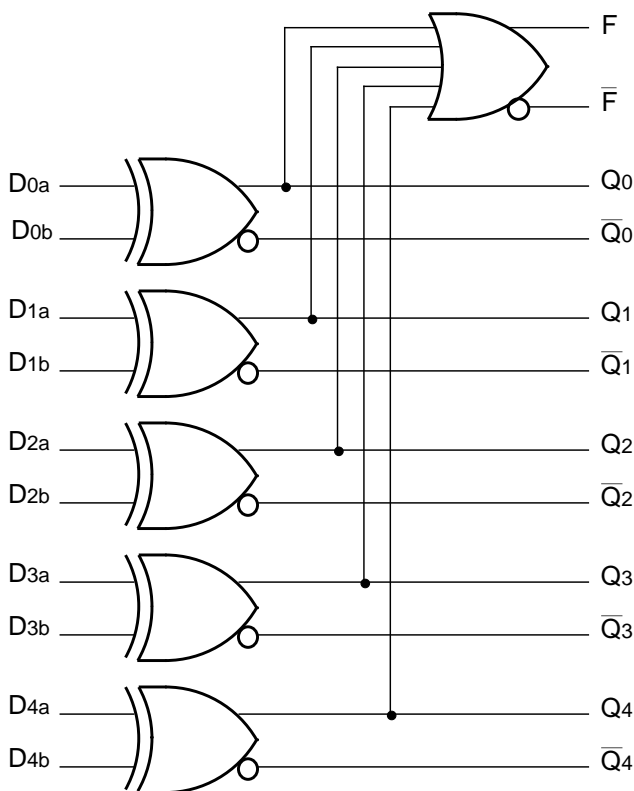

**PIN NAMES**

Pin	Function
Dna, Dnb	Data Inputs
Q0-Q4	XOR Outputs
$\bar{Q}0-\bar{Q}4$	XNOR Outputs
F	OR Output
$\bar{F}$	NOR Output
Vcco	Vcc to Output

**PACKAGE/ORDERING INFORMATION**

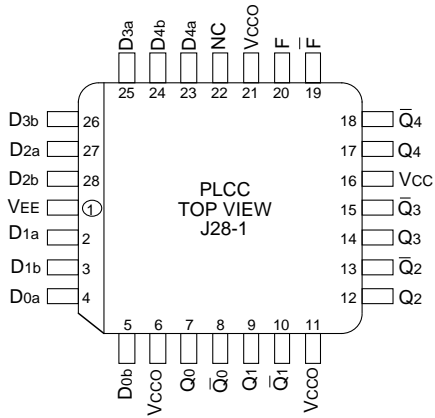

**28-Pin PLCC (J28-1)**

**Ordering Information<sup>(1)</sup>**

Part Number	Package Type	Operating Range	Package Marking	Lead Finish
SY10E107JC	J28-1	Commercial	SY10E107JC	Sn-Pb
SY10E107JCTR <sup>(2)</sup>	J28-1	Commercial	SY10E107JC	Sn-Pb
SY100E107JC	J28-1	Commercial	SY100E107JC	Sn-Pb
SY100E107JCTR <sup>(2)</sup>	J28-1	Commercial	SY100E107JC	Sn-Pb
SY10E107JZ <sup>(3)</sup>	J28-1	Commercial	SY10E107JZ with Pb-Free bar-line indicator	Matte-Sn
SY10E107JZTR <sup>(2, 3)</sup>	J28-1	Commercial	SY10E107JZ with Pb-Free bar-line indicator	Matte-Sn
SY100E107JZ <sup>(3)</sup>	J28-1	Commercial	SY100E107JZ with Pb-Free bar-line indicator	Matte-Sn
SY100E107JZTR <sup>(2, 3)</sup>	J28-1	Commercial	SY100E107JZ with Pb-Free bar-line indicator	Matte-Sn

**Notes:**

1. Contact factory for die availability. Dice are guaranteed at T<sub>A</sub> = 25°C, DC Electricals only.
2. Tape and Reel.
3. Pb-Free package is recommended for new designs.

**LOGIC EQUATION**

$$F = (D0a \oplus D0b) + (D1a \oplus D1b) + (D2a \oplus D2b) + (D3a \oplus D3b) + (D4a \oplus D4b)$$

$$F = Q0 + Q1 + Q2 + Q3 + Q4$$

**DC ELECTRICAL CHARACTERISTICS**

VEE = VEE (Min.) to VEE (Max.); VCC = VCCO = GND

Symbol	Parameter	TA = 0°C			TA = +25°C			TA = +85°C			Unit	Condition	
		Min.	Typ.	Max.	Min.	Typ.	Max.	Min.	Typ.	Max.			
I <sub>IH</sub>	Input HIGH Current	—	—	200	—	—	200	—	—	200	μA	—	
I <sub>EE</sub>	Power Supply Current										mA	—	
		10E	—	42	50	—	42	50	—	42			50
		100E	—	42	50	—	42	50	—	48			58

**AC ELECTRICAL CHARACTERISTICS**

VEE = VEE (Min.) to VEE (Max.); VCC = VCCO = GND

Symbol	Parameter	TA = 0°C			TA = +25°C			TA = +85°C			Unit	Condition	
		Min.	Typ.	Max.	Min.	Typ.	Max.	Min.	Typ.	Max.			
t <sub>PD</sub>	Propagation Delay to Output D to Q D to F	250	410	600	250	410	600	250	410	600	ps	—	
		500	725	1000	500	725	1000	500	725	1000			
t <sub>skew</sub>	Within-Device Skew, D to Q	—	75	—	—	75	—	—	75	—	ps	1	
t <sub>r</sub> t <sub>f</sub>	Rise/Fall Time 20% to 80%	Q	275	450	700	275	450	700	275	450	700	ps	—
		F	300	475	700	300	475	700	300	475	700		

**Note:**

1. Within-device skew is defined as identical transitions on similar paths through a device.

28-PIN PLCC (J28-1)

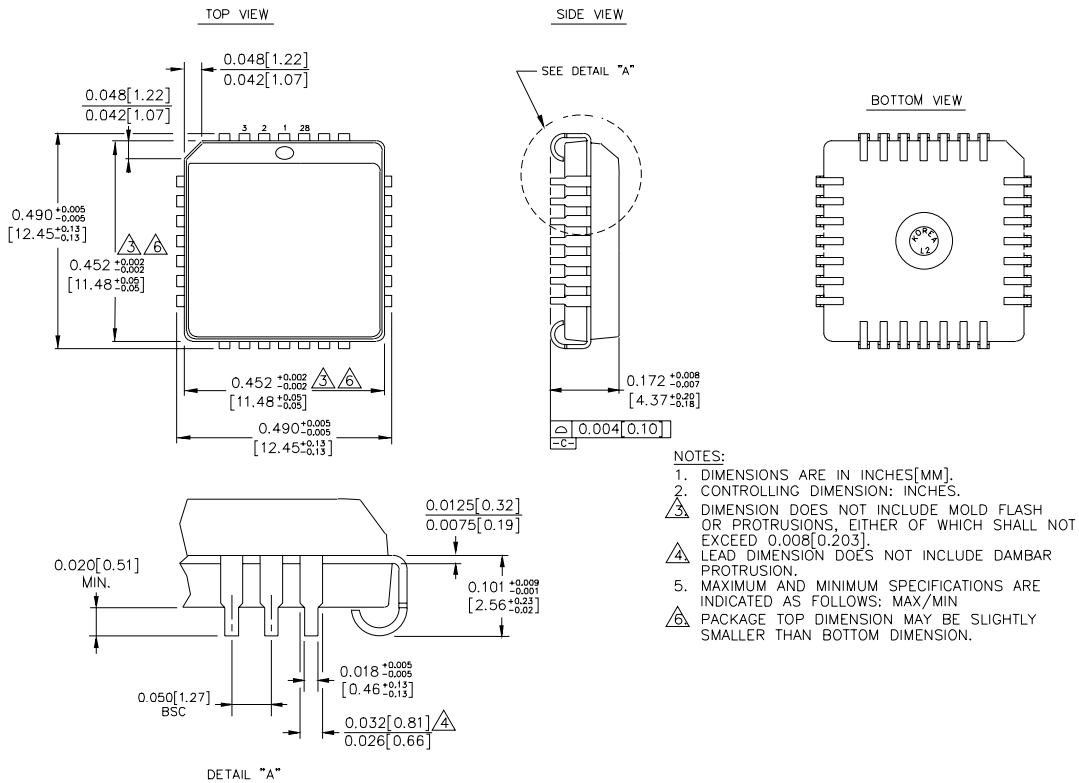

Rev. 03

**MICREL, INC. 2180 FORTUNE DRIVE SAN JOSE, CA 95131 USA**

TEL + 1 (408) 944-0800 FAX + 1 (408) 474-1000 WEB <http://www.micrel.com>

The information furnished by Micrel in this data sheet is believed to be accurate and reliable. However, no responsibility is assumed by Micrel for its use. Micrel reserves the right to change circuitry and specifications at any time without notification to the customer.

Micrel Products are not designed or authorized for use as components in life support appliances, devices or systems where malfunction of a product can reasonably be expected to result in personal injury. Life support devices or systems are devices or systems that (a) are intended for surgical implant into the body or (b) support or sustain life, and whose failure to perform can be reasonably expected to result in a significant injury to the user. A Purchaser's use or sale of Micrel Products for use in life support appliances, devices or systems is at Purchaser's own risk and Purchaser agrees to fully indemnify Micrel for any damages resulting from such use or sale.

© 2006 Micrel, Incorporated.