

- NOTES :
- 1. MATERIALS AND FINISH:
    - HOUSING: PA66
    - CONTACTS: COPPER ALLOY, FINISH: TIN OVER NICKEL UNDERPLATE
    - SPRING: STAINLESS STRIP STEEL
  - 2. MUST COMPLY WITH DIRECTIVE 2002/95/EC (ROHS)
  - 3. WIRE TYPES AND SIZES ACCEPTED
    - SOLID WIRE: 16AWG~20AWG.
    - STRIP LENGTH: 7.5mm~8.5mm
  - 4. PACKAGED IN TRAY.
  - 5. CURRENT RATING: 10Amp AC300V.
  - 6. OPERATION TEMPERATURE: -40°C TO +105°C

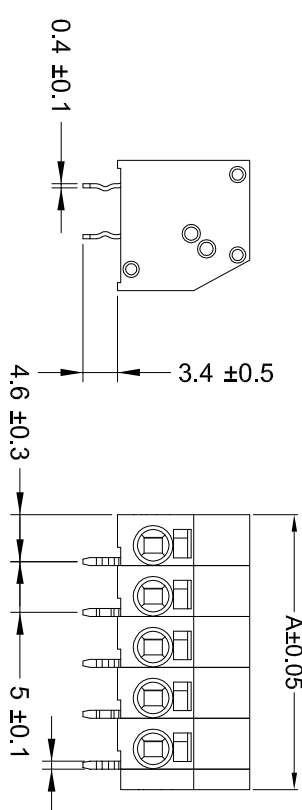

DETAIL INNER

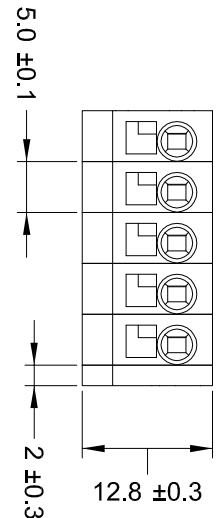
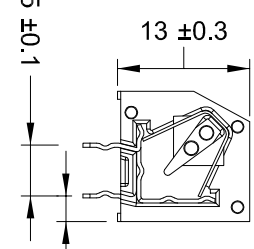

- COLOR CODE: \_\_\_\_\_
- SERIES CODE \_\_\_\_\_
- PIN No: \_\_\_\_\_
- 1=GREEN
  - 2=BLUE
  - 3=BROWN
  - 4=ORANGE
  - 5=GREY
  - 6=RED
  - 7=YELLOW
  - 8=PURPLE
  - 9=WHITE
  - 0=BLACK

REMARK: THE DIFFERENT COLORS COULD BE COMBINED TO THE NEW CONNECTOR P/Ns FOR CUSTOMER REQUEST.

42.00	8 POSN
37.00	7 POSN
32.00	6 POSN
27.00	5 POSN
22.00	4 POSN
17.00	3 POSN
12.00	2 POSN
A	NO. OF POSITIONS

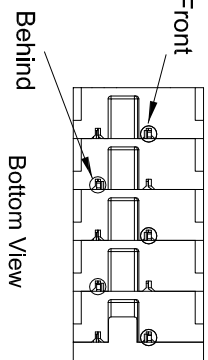
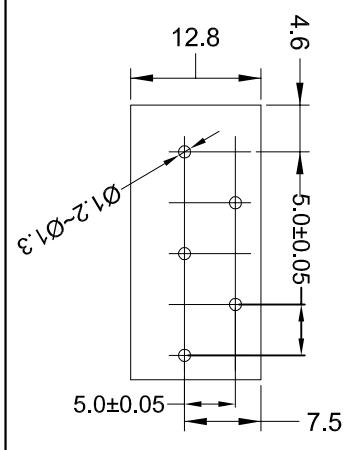

THIS DRAWING IS A CONTROLLED DOCUMENT

DESIGNER	CHK	DATE	REV
INTEGRATOR	APP	DATE	REV
TESTER	APP	DATE	REV
ASSEMBLER	APP	DATE	REV

DESIGNER: SHI YIANG  
 CHK: ISJANZONIS  
 INTEGRATOR: SHI YIANG  
 APP: ISJANZONIS  
 TESTER: SHI YIANG  
 APP: ISJANZONIS  
 ASSEMBLER: SHI YIANG  
 APP: ISJANZONIS

DATE: 108-13/078  
 APP: 114-10/078  
 VERSION: -

CUSTOMER DRAWING

SIZE: A2  
 CODE: 00779  
 SCALE: 1:1  
 SHEET: 1 OF 1  
 REV: A

50mm Pitch Modular Screwless Conn.

TE Connectivity