

Four-Channel Backlight Driver with Dual LDOs

General Description

The AAT2845A is a highly integrated power solution for single-cell lithium-ion-based LCD display applications. It includes a four-channel LED backlight driver and two integrated 200mA LDOs as additional power supplies for display and camera-related chipsets.

The backlight driver is a low noise, constant frequency charge pump DC/DC converter that uses a tri-mode load switch (1X), fractional (1.5X), and doubling (2X) conversion to maximize efficiency. Each of the four channels is capable of driving up to 20mA per channel.

Skywroks' S²Cwire™ (Simple Serial Control™) serial digital input is used to enable, disable, and set current for each LED with 16 available settings down to 50µA. The low current mode supply current can be as low as 50µA to save power and maintain high efficiency.

Each LED output is equipped with built-in protection for short-circuit and auto-disable functions. Built-in soft-start circuitry prevents excessive inrush current during start-up. A low current shutdown feature disconnects the load from V_{IN} and reduces quiescent current to less than 1µA.

The AAT2845A is available in a Pb-free, thermally-enhanced 20-pin 3x4mm TQFN package.

Features

- Input Voltage Range: 2.7V to 5.5V
- Four-Channel LED Driver:
 - Tri-Mode Charge Pump
 - Up to 20mA/Channel
 - Easy Control with Single Wire Interface
 - 16 Current Levels
 - Four Low Current Settings Down to 50µA
 - Low I_Q (50µA) for Low Current Mode
 - >90% Peak Efficiency
- Dual 200mA LDOs
- Automatic Soft-Start
- Over-Temperature Protection
- Available in 3x4mm TQFN34-20 Package
- -40°C to +85°C Temperature Range

Applications

- Camera Function Power Supplies
- Camera Phone Displays
- LCD Modules
- White LED Backlighting

Typical Application

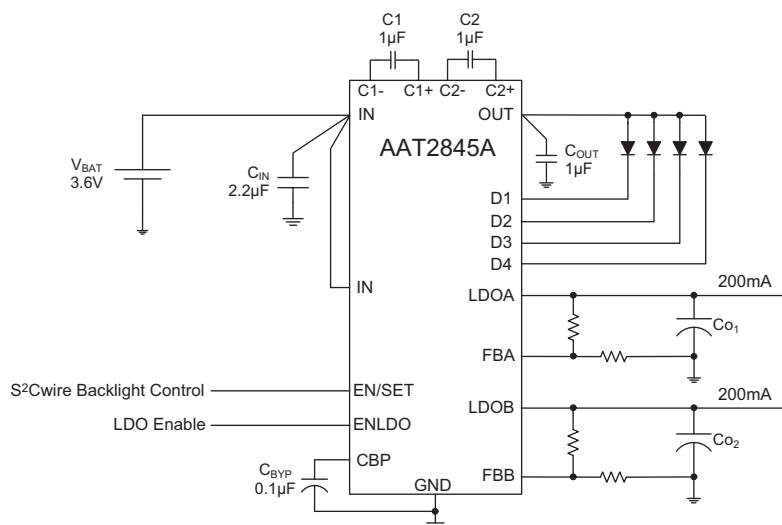

AAT2845A**Four-Channel Backlight Driver with Dual LDOs**

Pin Descriptions

Pin #	Symbol	Function
1	D2	Current sink input #2.
2	D1	Current sink input #1.
3	LDOB	Output of LDO B. Connect a 2.2 μ F or larger ceramic capacitor to ground.
4	IN	Input power supply for charge pump. Requires a 1 μ F or larger ceramic capacitor connected between this pin and ground.
5	PGND	Power ground.
6	IN	Input power pin for both LDOs. Connect a 1 μ F or larger ceramic capacitor from this pin to PGND.
7	FBA	Feedback pin of LDO A. Regulated at 1.2V.
8	LDOA	Output of LDO A. Connect a 2.2 μ F or larger ceramic capacitor to ground.
9	C2-	Flying capacitor 2 negative terminal.
10	C2+	Flying capacitor 2 positive terminal. Connect a 1 μ F ceramic capacitor between C2+ and C2-.
11	OUT	Charge pump output to drive load circuit. Connect a 1 μ F or larger ceramic capacitor between this pin and PGND.
12	C1-	Flying capacitor 1 negative terminal.
13	C1+	Flying capacitor 1 positive terminal. Connect a 1 μ F ceramic capacitor between C1+ and C1-.
14	EN/SET	S ² Cwire control pin for backlighting.
15	ENLDO	Enable pin for LDO A and B.
16	D4	Current sink input #4.
17	D3	Current sink input #3.
18	GND	Ground.
19	CBP	Bypass pin for the internal reference. Connect a 0.1 μ F ceramic capacitor from this pin to GND.
20	FBB	Feedback pin of LDO B. Regulated at 1.2V.
EP		Exposed paddle (bottom); connect to PGND as closely as possible to the device.

Pin Configuration

TQFN34-20

(Top View)

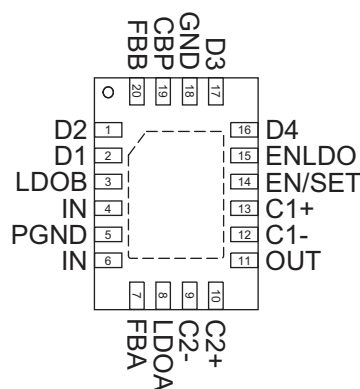

AAT2845A**Four-Channel Backlight Driver with Dual LDOs****Absolute Maximum Ratings¹**

$T_A = 25^\circ\text{C}$, unless otherwise noted.

Symbol	Description	Value	Units
	IN, OUT, D1, D2, D3, D4 Voltage to GND	-0.3 to 6.0	V
	C1+, C1-, C2+, C2- Voltage to GND	-0.3 to $V_{OUT} + 0.3$	V
	LDOA, LDOB, FBA, FBB, EN/SET, ENLDO, CBP Voltage to GND	-0.3 to $V_{IN} + 0.3$	V
	PGND Voltage to GND	-0.3 to +0.3	V
T_J	Operating Temperature Range	-40 to 150	$^\circ\text{C}$
T_{LEAD}	Maximum Soldering Temperature (at leads, 10 sec)	300	$^\circ\text{C}$

Thermal Information^{2, 3, 4}

Symbol	Description	Value	Units
θ_{JA}	Thermal Resistance	50	$^\circ\text{C}/\text{W}$
P_D	Maximum Power Dissipation	2	W

1. Stresses above those listed in Absolute Maximum Ratings may cause permanent damage to the device. Functional operation at conditions other than the operating conditions specified is not implied. Only one Absolute Maximum Rating should be applied at any one time.

2. Based on long-term current density limitation.

3. Derate 20mW/ $^\circ\text{C}$ above 40 $^\circ\text{C}$ ambient temperature.

4. Mounted on an FR4 circuit board.

AAT2845A**Four-Channel Backlight Driver with Dual LDOs****Electrical Characteristics¹**

$C_{IN} = C_{O1} = C_{O2} = 2.2\mu\text{F}$, $C_1 = C_2 = 1.0\mu\text{F}$, $C_{BP} = 0.1\mu\text{F}$; $T_A = 25^\circ\text{C}$, unless otherwise noted. Typical values are at $T_A = 25^\circ\text{C}$ and $V_{IN} = 3.6\text{V}$.

Symbol	Description	Conditions	Min	Typ	Max	Units
Power Supply						
V_{IN}	Supply Voltage		2.7		5.5	V
I_{SHDN}	Total Shutdown Current at VIN and LDOIN	EN/SET = ENLDO = GND			1.0	μA
Charge Pump						
I_{CC}	Operating Current	1X Mode, $3.0 \leq V_{IN} \leq 5.5$, Active, No Load Current			1.0	mA
		1.5X Mode, $3.0 \leq V_{IN} \leq 5.5$, Active, No Load Current			3.0	
		2X Mode, $3.0 \leq V_{IN} \leq 5.5$, Active, No Load Current			5.0	
		50 μA Setting, 1X Mode		50		μA
I_{DX}	Average Current Accuracy	20mA Setting, $T_A = 25^\circ\text{C}$	18	20	22	mA
		1mA Setting, $T_A = 25^\circ\text{C}$	0.9	1.0	1.1	
$I_{(D-Match)}$	Current Matching ²	$V_{IN} - V_F = 1.5\text{V}$		0.5	1.0	%
V_{TH}	1X to 1.5X or 1.5X to 2X Transition Threshold at Any DX Pin	20mA Setting, $T_A = 25^\circ\text{C}$		150		mV
T_{SS}	Soft-Start Time			100		μs
F_{CLK}	Clock Frequency			1		MHz
T_{SD}	Over-Temperature Shutdown Threshold			140		$^\circ\text{C}$
T_{HYS}	Over-Temperature Shutdown Hysteresis			15		$^\circ\text{C}$
EN/ SET Logic Control						
$T_{EN/SET LO}$	EN/SET Low Time		0.3		75	μs
$T_{EN/SET HI MIN}$	Minimum EN/SET High Time			50		ns
$T_{EN/SET HI MAX}$	Maximum EN/SET High Time				75	μs
T_{OFF}	EN/SET Off Timeout				500	μs
T_{LAT}	EN/SET Latch Timeout				500	μs
$I_{EN/SET}$	EN/SET Input Leakage	$V_{EN/SET} = V_{IN} = 5\text{V}$	-1		1	μA
LDOs						
I_{IN}^{IN}	IN Operating Current	ENLDO = IN, EN/SET = AGND, No Load		80	150	μA
V_{FB}	Feedback Voltage	$I_{OUT} = 1\text{mA to } 200\text{mA}$	1.17	1.2	1.23	V
V_{DO}	Dropout Voltage	$I_{OUT} = 150\text{mA}$		150	300	mV
$\frac{\Delta V_{OUT}}{V_{OUT}} \cdot \Delta V_{IN}$	Line Regulation	$V_{IN} = (V_{OUT} + 1\text{V}) \text{ to } 5.0\text{V}$		0.09		%/V
PSRR	Power Supply Rejection Ratio	$I_{OUT} = 10\text{mA}, 1\text{kHz}$		50		dB
LDO Logic Control						
V_{IL}	EN/SET, ENLDO Pins Logic Low Threshold				0.4	V
V_{IH}	EN/SET, ENLDO Pins Logic High Threshold		1.4			V

1. The AAT2845A is guaranteed to meet performance specifications over the -40°C to $+85^\circ\text{C}$ operating temperature range and is assured by design, characterization, and correlation with statistical process controls.

2. Current matching is defined as the deviation of any sink current from the average of all active channels.

AAT2845A

Four-Channel Backlight Driver with Dual LDOs

Typical Characteristics

$C_{IN} = C_{O1} = C_{O2} = 2.2\mu F$, $C_1 = C_2 = 1.0\mu F$, $C_{BP} = 0.1\mu F$; $T_A = 25^\circ C$, unless otherwise noted. Typical values are at $T_A = 25^\circ C$ and $V_{IN} = 3.6V$.

Backlight Efficiency vs. Supply Voltage

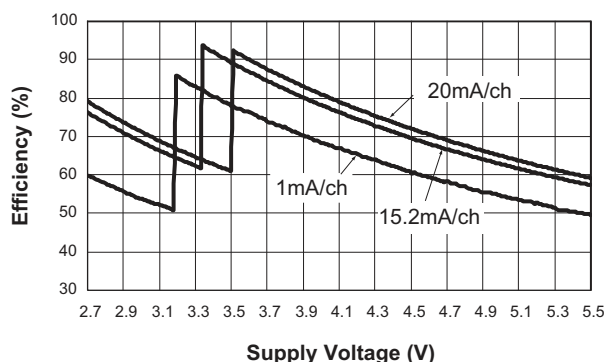

Turn-On to 1X Mode
($V_{IN} = 4.2V$; 20mA/ch Load)

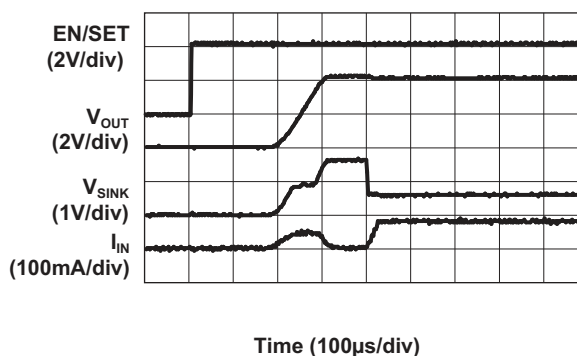

Turn-On to 1.5X Mode
($V_{IN} = 3.5V$; 20mA/ch Load)

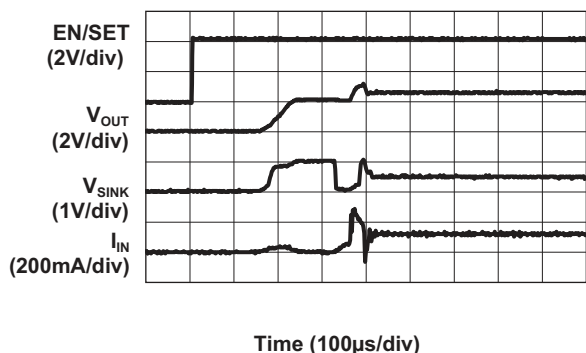

Turn-On to 2X Mode
($V_{IN} = 2.8V$; 20mA/ch Load)

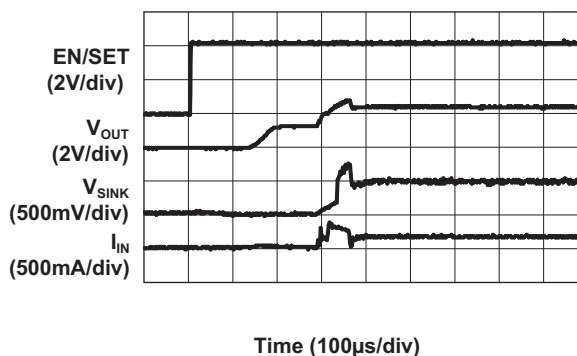

Turn-Off from 1.5X Mode Backlight

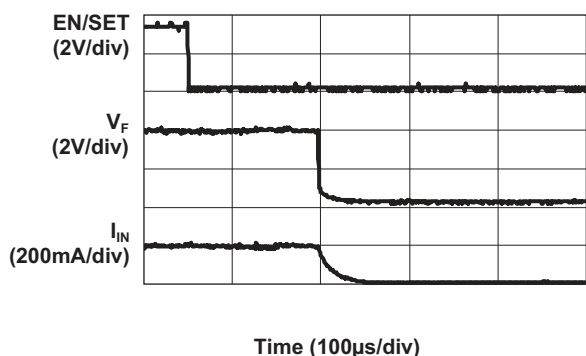

AAT2845A

Four-Channel Backlight Driver with Dual LDOs

Typical Characteristics

$C_{IN} = C_{O1} = C_{O2} = 2.2\mu F$, $C_1 = C_2 = 1.0\mu F$, $C_{BP} = 0.1\mu F$; $T_A = 25^\circ C$, unless otherwise noted. Typical values are at $T_A = 25^\circ C$ and $V_{IN} = 3.6V$.

Backlight Operating Characteristic
($V_{IN} = 2.9V$; 2X Mode; 13.5mA/ch Load)

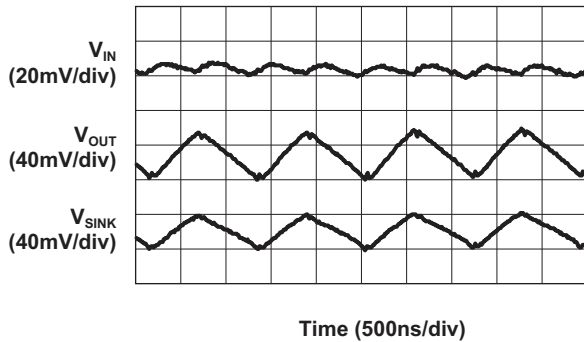

Backlight Operating Characteristic
($V_{IN} = 2.9V$; 2X Mode; 20mA/ch Load)

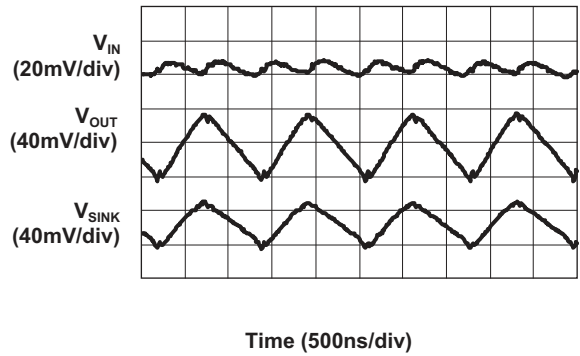

Backlight Operating Characteristic
($V_{IN} = 2.9V$; 2X Mode; 13.5mA/ch Load)

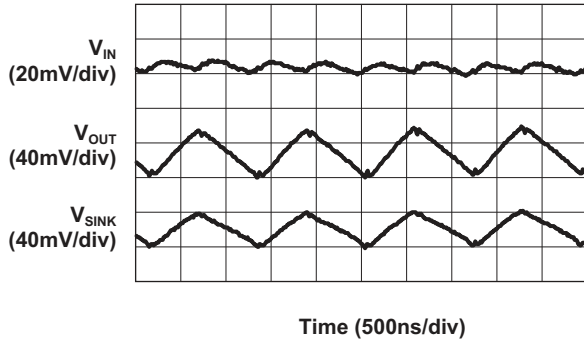

Backlight Operating Characteristic
($V_{IN} = 3.7V$; 1.5X Mode; 20mA/ch Load)

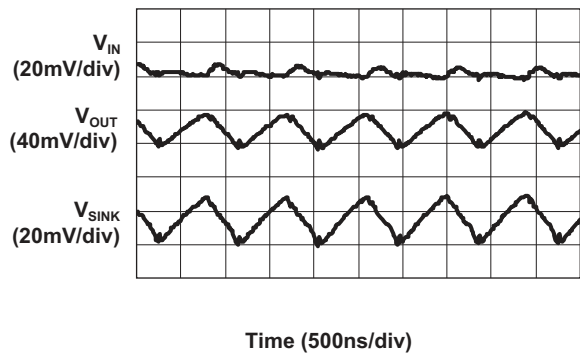

EN/SET Latch Timeout vs. Supply Voltage

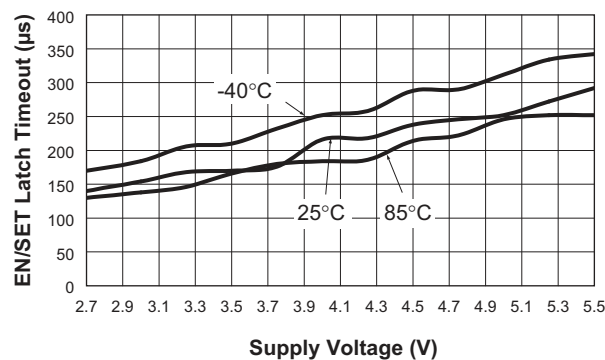

EN/SET Off Timeout vs. Supply Voltage

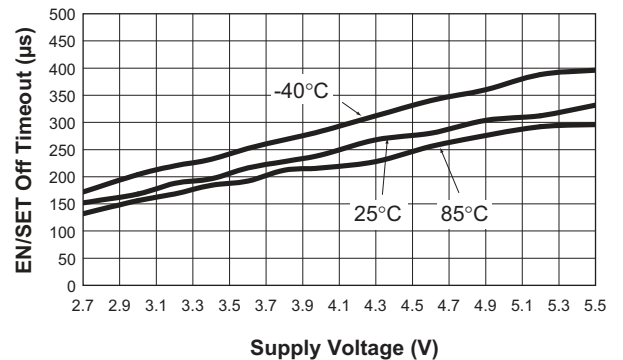

AAT2845A

Four-Channel Backlight Driver with Dual LDOs

Typical Characteristics

$C_{IN} = C_{O1} = C_{O2} = 2.2\mu F$, $C_1 = C_2 = 1.0\mu F$, $C_{BP} = 0.1\mu F$; $T_A = 25^\circ C$, unless otherwise noted. Typical values are at $T_A = 25^\circ C$ and $V_{IN} = 3.6V$.

EN/SET Low Threshold Voltage vs. Supply Voltage

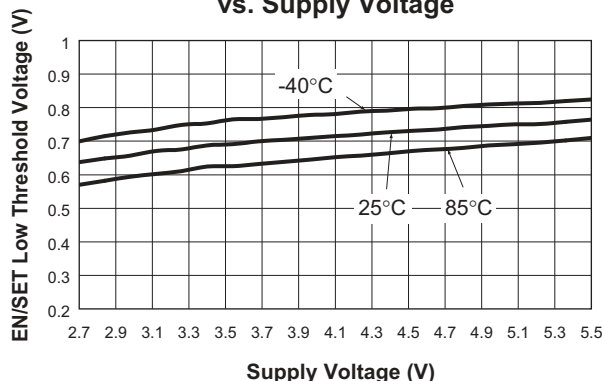

EN/SET High Threshold Voltage vs. Supply Voltage

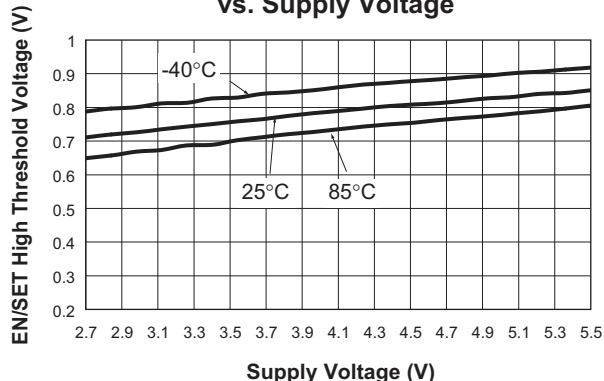

LDOs A and B Turn-On Characteristic

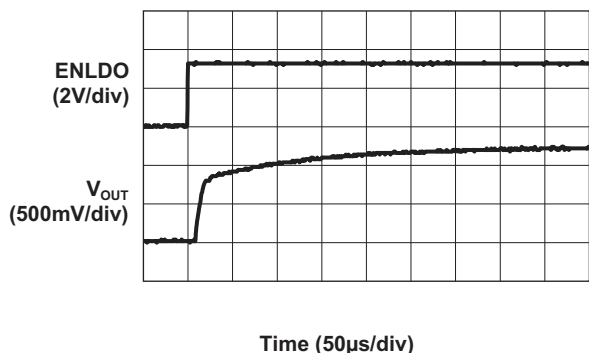

LDOs A and B Line Regulation (10mA Load)

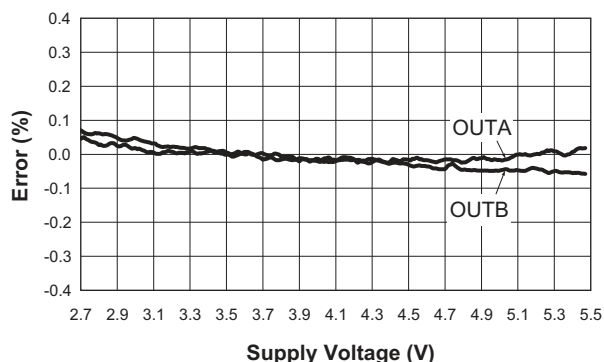

LDOs A and B Load Regulation (V_{OUT} = 1.2V)

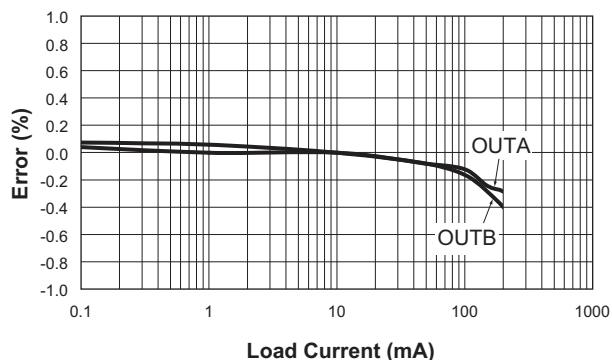

LDOs A and B Line Transient Response (V_{OUT} = 2.5V; 10mA Load)

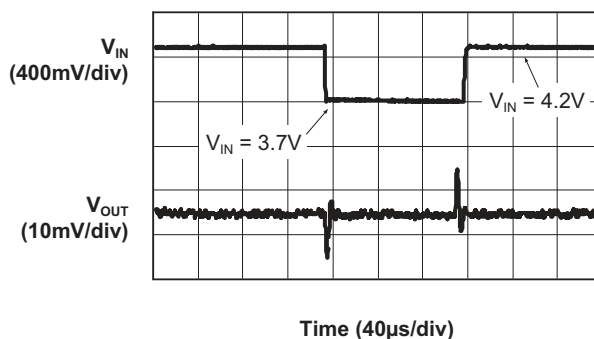

AAT2845A

Four-Channel Backlight Driver with Dual LDOs

Typical Characteristics

$C_{IN} = C_{O1} = C_{O2} = 2.2\mu\text{F}$, $C_1 = C_2 = 1.0\mu\text{F}$, $C_{BP} = 0.1\mu\text{F}$; $T_A = 25^\circ\text{C}$, unless otherwise noted. Typical values are at $T_A = 25^\circ\text{C}$ and $V_{IN} = 3.6\text{V}$.

LDOs A and B Load Transient Response ($V_{OUT} = 2.5\text{V}$)

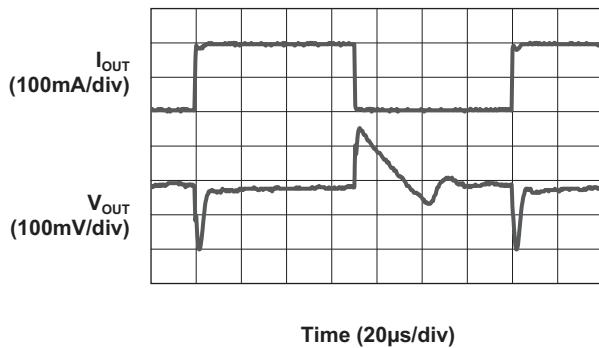

AAT2845A

Four-Channel Backlight Driver with Dual LDOs

Functional Block Diagram

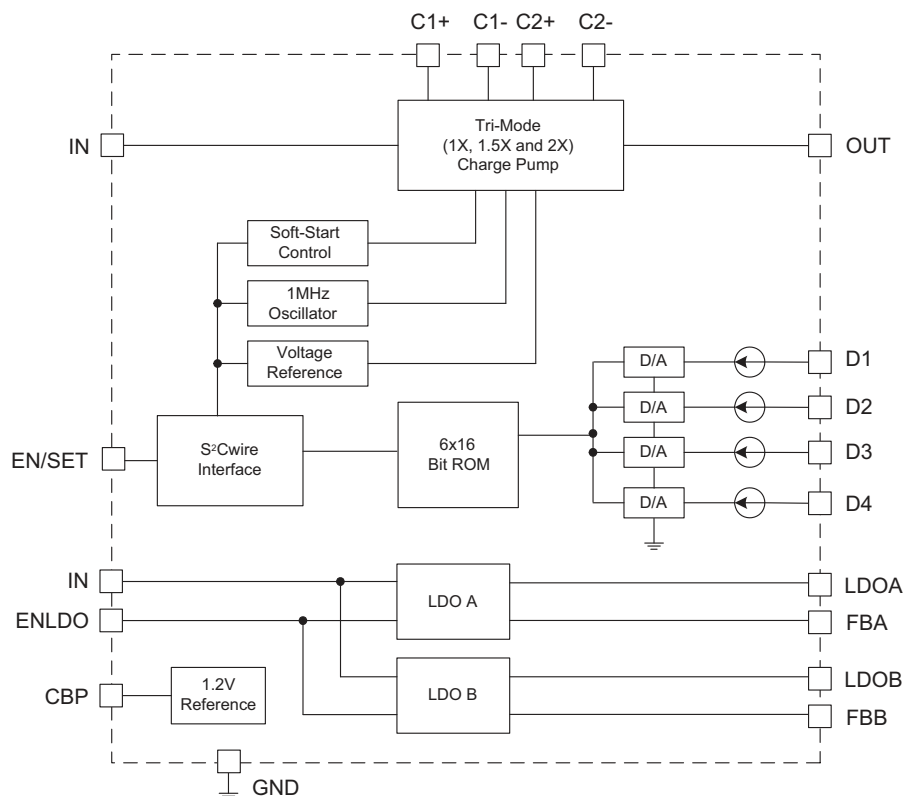

Functional Description

The AAT2845A is an integrated solution for LCD display applications with a built-in driver for white LED backlight and two LDO voltage regulators for logic power supplies.

The backlight driver is a tri-mode load switch (1X) and high-efficiency (1.5X or 2X) charge pump device. To maximize power conversion efficiency, an internal sensing circuit monitors the voltage required on each constant current sink input and sets the load switch and charge pump modes based on the input battery voltage and the current sink input voltage. As the battery discharges over time, the charge pump is enabled when any of the four current sink inputs nears dropout. The charge pump initially starts in 1.5X mode. If the charge pump output droops enough for any current source output to become close to dropout, the charge pump will automatically transition to 2X mode. The charge pump requires only four external components: two 1 μ F ceramic capacitors for the charge pump flying capacitors (C_1 and C_2), one 1 μ F ceramic input capacitor (C_{IN}), and one 0.33 μ F to 1 μ F ceramic charge pump output capacitor (C_{OUT}).

The four constant current sink inputs (D1 to D4) can drive four individual LEDs with a maximum current of 20mA each. The unused sink inputs must be connected to the OUT pin; otherwise the part will operate only in 2X charge pump mode. The S²Cwire serial interface enables the charge pump and sets the current sink magnitudes.

Constant Current Output Level Settings

The constant current sink levels for D1 to D4 are set via the S²Cwire serial interface according to a logarithmic scale for the first 12 codes, and a separate low-current scale for the last four codes. Because the inputs D1 to D4 are true independent constant current sinks, the voltage observed on any single given input will be determined by the difference between V_{OUT} and the actual forward voltage (V_F) of the LED being driven.

Since the current level is programmable, no PWM (pulse width modulation) or additional control circuitry is needed to control LED brightness. This feature greatly reduces the burden on a microcontroller or system IC to manage LED or display brightness, allowing the user to "set it and forget it." With its high-speed serial interface

Four-Channel Backlight Driver with Dual LDOs

(>1MHz data rate), the LED current drive can be changed successively to brighten or dim LEDs in smooth transitions (e.g., to fade out) or in abrupt steps, giving the user complete programmability and real-time control of LED brightness.

The last four codes of the current level scale engage a reduced quiescent current mode that enhances the low-current setting efficiency. This mode is especially useful for low-current applications where a continuous, low-current state is maintained for a substantial length of time.

S²Cwire Serial Interface

The current sink magnitude is controlled by Skyworks' S²Cwire serial digital input. The interface records rising edges of the EN/SET pin and decodes them into 16 different states. The 16 current level settings available are indicated in Table 1.

Data	Output (mA/ Ch)	Data	Output (mA/ Ch)
1	20	9	6.8
2	18.4	10	5.2
3	16.8	11	3.5
4	15.2	12	2.0
5	13.5	13	1.0
6	11.9	14	0.5
7	10	15	0.10
8	8.4	16	0.05

Table 1: Current Level Settings.

The S²Cwire serial interface has flexible timing. Data can be clocked-in at speeds higher than 1MHz, or much slower, such as 15kHz. After data is applied, EN/SET is held high to latch the data. Once EN/SET has been held in the logic high state for time T_{LAT} (500 μ s), the programmed current becomes active and the internal data register is reset to zero. For subsequent current level programming, the number of rising edges corresponding

to the desired code must be applied on the EN/SET pin. When the EN/SET pin is held low for an amount of time longer than T_{OFF} (500 μ s), the AAT2845A enters shutdown mode and draws less than 1 μ A from the input. An internal data register is reset to zero during shutdown.

Auto-Disable Feature

The charge pump in the AAT2845A is equipped with an auto-disable feature for each LED channel. After the IC is enabled and started up, a test current of 100 μ A (typical) is forced through each sink channel. The channel will be disabled if the voltage of that particular DX pin does not drop to a certain threshold. This feature is convenient for disabling an unused channel or during an LED fail-short event.

Low Dropout Regulators

The AAT2845A includes two LDO linear regulators. The regulators run from the same 2.7V to 5.5V input voltage as the charge pump. The regulators use a single on/off control input, ENLDO. The LDO output voltages are set through a resistive voltage divider from the output (OUTA or OUTB) to the feedback input (FBA or FBB). The ratio of resistor values determines the LDO output voltage. The low 200mV dropout voltage at 200mA load current allows the regulator to maintain output voltage regulation.

Each LDO regulator can supply a continuous load current up to 200mA. Both LDOs include current limiting and thermal overload protection to prevent damage to the load or to the LDOs.

Thermal Protection

The charge pump has a built-in thermal protection circuit that will shut down the charge pump and the LDOs if the die temperature rises above the thermal limit, as is the case during a short-circuit of the OUT pin.

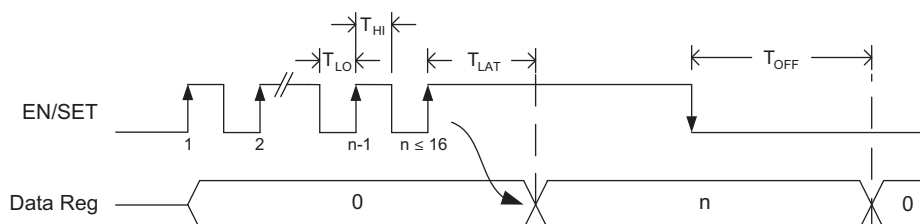

Figure 1: S²Cwire Serial Interface Timing.

AAT2845A

Four-Channel Backlight Driver with Dual LDOs

Applications Information

LED Selection

The AAT2845A is specifically intended for driving white LEDs. However, the device design will allow the AAT2845A to drive most types of LEDs with forward voltage specifications ranging from 2.0V to 4.7V. LED applications may include mixed arrangements for display backlighting, color (RGB) LEDs, infrared (IR) diodes, and any other load needing a constant current source generated from a varying input voltage. Since the D1 to D4 constant current sinks are matched with negligible voltage dependence, the constant current channels will be matched regardless of the specific LED forward voltage (V_f) levels.

The low dropout current sinks in the AAT2845A maximize performance and make it capable of driving LEDs with high forward voltages. Multiple channels can be combined to obtain a higher LED drive current without complication.

Device Switching Noise Performance

The AAT2845A operates at a fixed frequency of approximately 1MHz to control noise and limit harmonics that can interfere with the RF operation of cellular telephone handsets or other communication devices. Back-injected noise appearing on the input pin of the charge pump is 20mV peak-to-peak, typically ten times less than inductor-based DC/DC boost converter white LED backlight solutions. The AAT2845A soft-start feature prevents noise transient effects associated with inrush currents during start-up of the charge pump circuit.

Shutdown

Since the sink switches are the only power returns for all loads, there is no leakage current when all of the sink switches are disabled. To activate the shutdown mode, hold the EN/SET input low for longer than T_{OFF} (500 μ s). In this state, the AAT2845A typically draws less than 1 μ A from the input. Data and address registers are reset to 0 in shutdown.

LDO Output Voltage Programming

The output voltages for LDOA and LDOB are programmed by an external resistor divider network. As shown below, the selection of R8 and R9 is a straightforward matter.

R9 is chosen by considering the tradeoff between the feedback network bias current and resistor value. Higher resistor values allow stray capacitance to become a larger factor in circuit performance, whereas lower resistor values increase bias current and decrease efficiency.

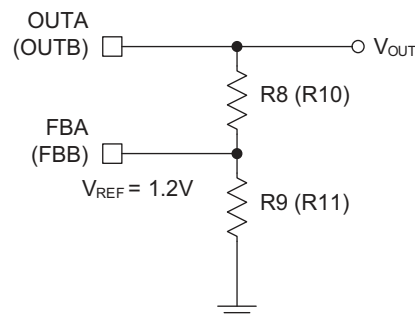

Figure 2: Selection of External Resistors.

To select appropriate resistor values, first choose R9 such that the feedback network bias current is reasonable. Then, according to the desired V_{OUT} , calculate R8 according to the equation below. An example calculation follows.

R9 is chosen to be 120K, resulting in a small feedback network bias current of $1.2V/120K = 10\mu A$. The desired output voltage is 1.8V. From this information, R8 is calculated from the equation below.

$$R8 = \frac{R9(V_{OUT} - 1.2V)}{1.2V}$$

The result is $R8 = 60K$. Since 60K is not a standard 1% value, 60.4K is selected. From this example calculation, for $V_{OUT} = 1.8V$, use $R9 = 120K$ and $R8 = 60.4K$. A table of example output voltages and corresponding resistor values is provided below.

Standard 1% Values ($R9, R11 = 120K$)	
V_{OUT} (V)	R8, R10 (Ω)
2.8	160K
2.5	130K
2.0	79.6K
1.8	60.4K
1.5	30.1K

Table 2: Example Output Voltages and Corresponding Resistor Values

AAT2845A

Four-Channel Backlight Driver with Dual LDOs

Power Efficiency and Device Evaluation

The charge pump efficiency discussion in the following sections accounts only for efficiency of the charge pump section itself. Due to the unique circuit architecture and design of the AAT2845A, it is very difficult to measure efficiency in terms of a percent value comparing input power over output power.

Since the AAT2845A outputs are pure constant current sinks and typically drive individual loads, it is difficult to measure the output voltage for a given output (D1 to D4) to derive an overall output power measurement. For any given application, white LED forward voltage levels can differ, yet the output drive current will be maintained as a constant.

This makes quantifying output power a difficult task when taken in the context of comparing to other white LED driver circuit topologies. A better way to quantify total device efficiency is to observe the total input power to the device for a given LED current drive level. The best white LED driver for a given application should be based on trade-offs of size, external component count, reliability, operating range, and total energy usage...*not just % efficiency.*

The AAT2845A efficiency may be quantified under very specific conditions and is dependent upon the input voltage versus the output voltage seen across the loads applied to outputs D1 through D4 for a given constant current setting. Depending on the combination of V_{IN} and voltages sensed at the current sinks, the device will operate in load switch mode. When any one of the voltages sensed at the current sinks nears dropout, the device will operate in 1.5X or 2X charge pump mode. Each of these modes will yield different efficiency values. Refer to the following two sections for explanations for each operational mode.

1X Mode Efficiency

The AAT2845A 1X mode is operational at all times and functions alone to enhance device power conversion efficiency when V_{IN} is higher than the voltage across the load. When in 1X mode, voltage conversion efficiency is defined as output power divided by input power:

$$\eta = \frac{P_{OUT}}{P_{IN}}$$

The expression to define the ideal efficiency (η) can be rewritten as:

$$\eta = \frac{P_{OUT}}{P_{IN}} = \frac{V_{OUT} \cdot I_{OUT}}{V_{IN} \cdot I_{OUT}} = \frac{V_{OUT}}{V_{IN}}$$

-or-

$$\eta(\%) = 100 \left(\frac{V_{OUT}}{V_{IN}} \right)$$

1.5X and 2X Charge Pump Mode Efficiency

The AAT2845A contains a fractional charge pump which will boost the input supply voltage in the event where V_{IN} is less than the voltage required to supply the output. The efficiency (η) can be simply defined as a linear voltage regulator with an effective output voltage that is equal to one and one half or two times the input voltage. Efficiency (η) for an ideal 1.5X charge pump can typically be expressed as the output power divided by the input power.

$$\eta = \frac{P_{OUT}}{P_{IN}}$$

In addition, with an ideal 1.5X charge pump, the output current may be expressed as 2/3 of the input current. The expression to define the ideal efficiency (η) can be rewritten as:

$$\eta = \frac{P_{OUT}}{P_{IN}} = \frac{V_{OUT} \cdot I_{OUT}}{V_{IN} \cdot 1.5I_{OUT}} = \frac{V_{OUT}}{1.5V_{IN}}$$

-or-

$$\eta(\%) = 100 \left(\frac{V_{OUT}}{1.5V_{IN}} \right)$$

For a charge pump with an output of 5V and a nominal input of 3.5V, the theoretical efficiency is 95%. Due to internal switching losses and IC quiescent current consumption, the actual efficiency can be measured at 93%. These figures are in close agreement for output load conditions from 1mA to 100mA. Efficiency will decrease substantially as load current drops below 1mA or when the level of V_{IN} approaches V_{OUT} .

AAT2845A

Four-Channel Backlight Driver with Dual LDOs

The same calculations apply for 2X mode, where the output current then becomes 1/2 of the input current.

Capacitor Selection

Careful selection of the four external capacitors C_{IN} , C_1 , C_2 , and C_{OUT} is important because they will affect turn-on time, output ripple, and transient performance. Optimum performance will be obtained when low equivalent series resistance (ESR) ceramic capacitors are used; in general, low ESR may be defined as less than 100m Ω . A value of 1 μ F for all four capacitors is a good starting point when choosing capacitors. If the constant current sinks are only programmed for light current levels, then the capacitor size may be decreased.

Capacitor Characteristics

Ceramic composition capacitors are highly recommended over all other types of capacitors for use with the AAT2845A. Ceramic capacitors offer many advantages over their tantalum and aluminum electrolytic counterparts. A ceramic capacitor typically has very low ESR, is lowest cost, has a smaller PCB footprint, and is non-polarized. Low ESR ceramic capacitors help maximize charge pump transient response. Since ceramic capacitors are non-polarized, they are not prone to incorrect connection damage.

Equivalent Series Resistance

ESR is an important characteristic to consider when selecting a capacitor. ESR is a resistance internal to a capacitor that is caused by the leads, internal connections, size or area, material composition, and ambient temperature. Capacitor ESR is typically measured in milliohms for ceramic capacitors and can range to more than several ohms for tantalum or aluminum electrolytic capacitors.

Ceramic Capacitor Materials

Ceramic capacitors less than 0.1 μ F are typically made from NPO or COG materials. NPO and COG materials generally have tight tolerance and are very stable over

temperature. Larger capacitor values are usually composed of X7R, X5R, Z5U, or Y5V dielectric materials. Large ceramic capacitors (i.e., larger than 2.2 μ F) are often available in low-cost Y5V and Z5U dielectrics, but capacitors larger than 1 μ F are not typically required for AAT2845A applications.

Capacitor area is another contributor to ESR. Capacitors that are physically large will have a lower ESR when compared to an equivalent material smaller capacitor. These larger devices can improve circuit transient response when compared to an equal value capacitor in a smaller package size.

Evaluation Board User Interface

The user interface for the AAT2845A evaluation board is provided by three buttons and two connection terminals. The board is operated by supplying external power and pressing individual buttons or button combinations. The table below indicates the function of each button or button combination.

To power-on the evaluation board, connect a power supply or battery to the DC- and DC+ terminals. Close the board's supply connection by positioning the J1 jumper to the ON position. A red LED indicates that power is applied.

The evaluation board is made flexible so that the user can disconnect the enable lines from the microcontroller and apply external enable signals. By removing the jumpers from J2, and/or J3, external enable signals can be applied to the board. External enable signals must be applied to the ON pin of each J2, or J3 terminal.

When applying external enable signals, consideration must be given to the voltage levels. The externally applied voltages should not exceed the supply voltage that is applied to the IN pins of the device (DC+).

The LDO loads can be connected directly to the evaluation board. For adequate performance, be sure to connect the load between OUTA/OUTB and DC- as opposed to some other GND in the system.

AAT2845A

Four-Channel Backlight Driver with Dual LDOs

Button(s) Pushed ¹	Description
DATA	Increment the backlight data setting. Hold down the button to auto-cycle through the brightness levels.
LIGHT	Toggle ON/OFF the backlighting section. Set the brightness level using the DATA button.
LIGHT+DATA	Decrement the backlight data setting. Hold down to auto-cycle.
ENLDO	Toggle ON/OFF the LDOs.
DATA+LIGHT+ENLDO	Reset. Clear data and bring all enable lines low.

Table 3: Evaluation Board User Interface.

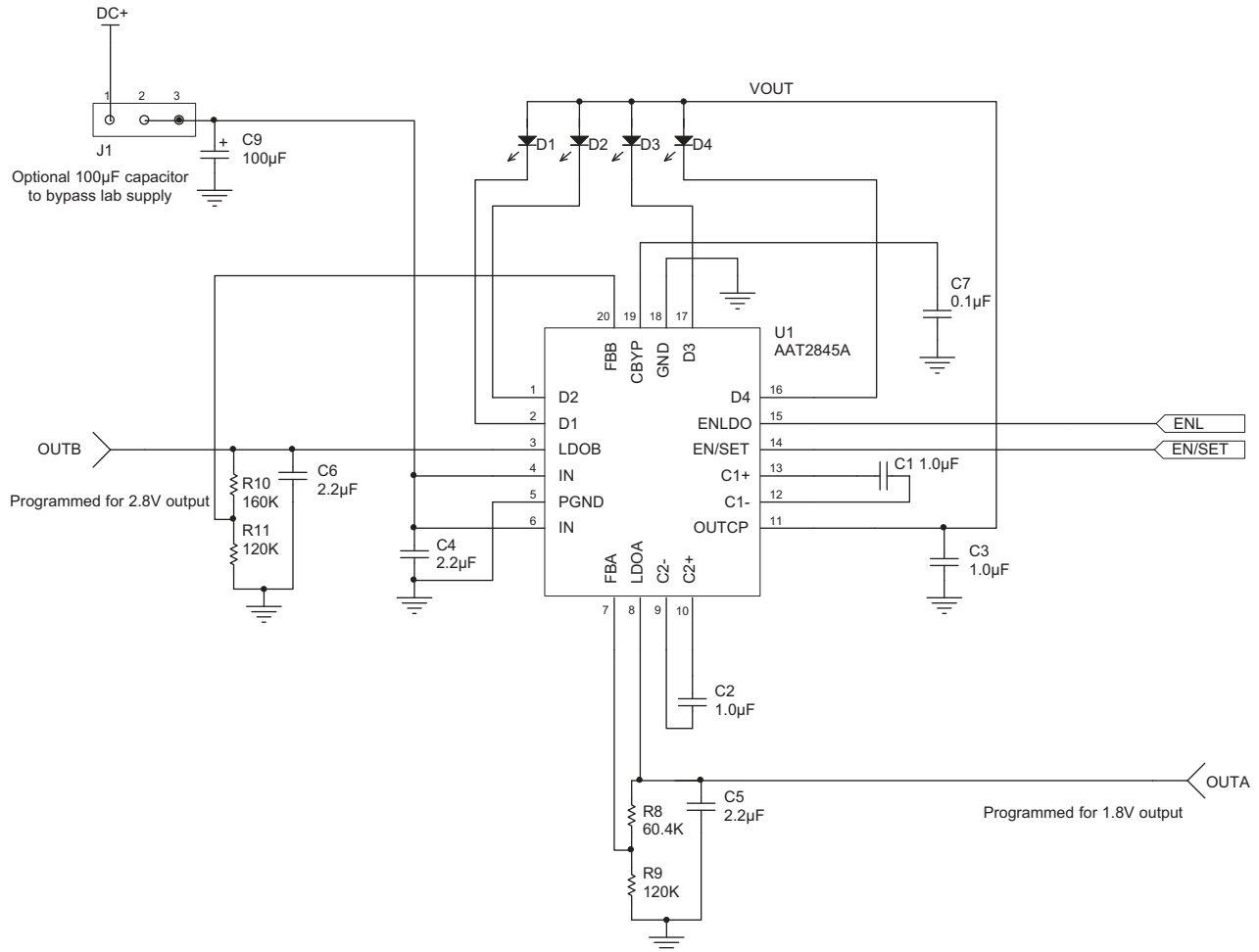

Figure 5: AAT2845A Section Schematic.

1. The "+" indicates that these buttons are pressed and released together.

AAT2845A

Four-Channel Backlight Driver with Dual LDOs

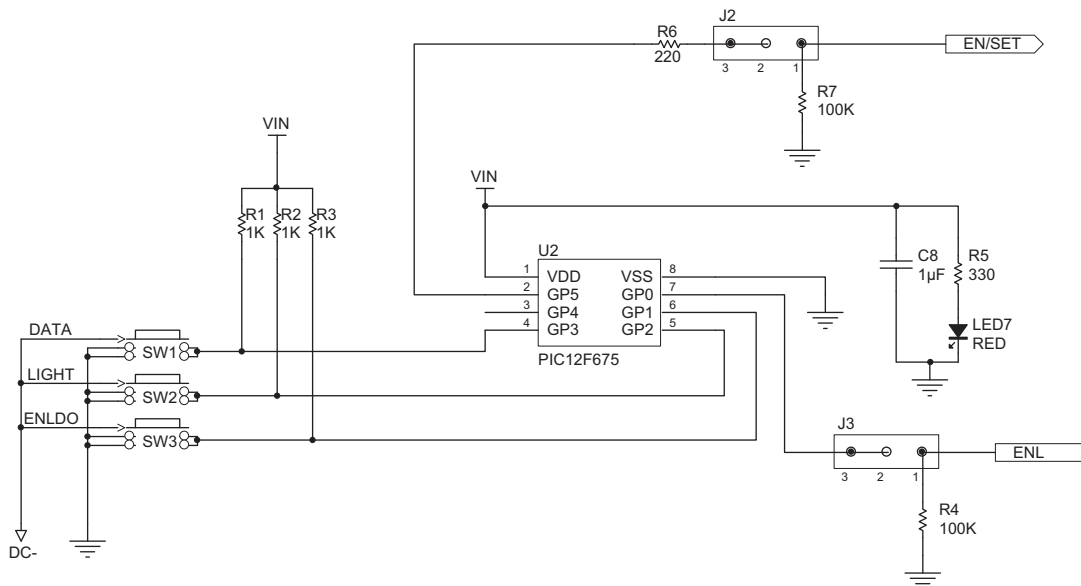

Figure 6: MCU Section Schematic.

Evaluation Board Component Listing

Component	Part#	Description	Manufacturer
U1	AAT2845AIML-EE-T1	Four-Channel Backlight Driver with Dual LDOs	Skyworks
U2	PIC12F675	8-bit CMOS, FLASH MCU; 8-pin PDIP	Microchip
D1 - D4	LW M673	Mini TOPLED White LED; SMT	OSRAM
C1 - C3	GRM18x	1.0µF, 10V, X5R, 0603, ceramic	Murata
C4 - C6	GRM18x	2.2µF, 10V, X5R, 0603, ceramic	Murata
C7	GRM18x	0.1µF, 16V, X7R, 0603, ceramic	Murata
C8	GRM31x	1µF, 10V, X5R, 1206, ceramic	Murata
C9	TAJBx	100µF, 10V, 10µA, tantalum	AVX
R1 - R3	Chip Resistor	1K, 5%, 1/4W; 1206	Vishay
R4, R7	Chip Resistor	100K, 5%, 1/4W; 1206	Vishay
R5	Chip Resistor	330, 5%, 1/4W; 1206	Vishay
R6	Chip Resistor	220, 5%, 1/4W; 1206	Vishay
R8	Chip Resistor	60.4K, 1%, 1/10W; 0603	Vishay
R9, R11	Chip Resistor	120K, 1%, 1/10W; 0603	Vishay
R10	Chip Resistor	160K, 1%, 1/10W; 0603	Vishay
J1 - J3	PRPN401PAEN	Conn. Header, 2mm zip	Sullins Electronics
LED7	CMD15-21SRC/TR8	Red LED; 1206	Chicago Miniature Lamp
SW1 - SW3	PTS645TL50	Switch Tact, SPST, 5mm	ITT Industries

AAT2845A**Four-Channel Backlight Driver with Dual LDOs**

Ordering Information

Package	Marking ¹	Part Number (Tape and Reel) ²
TQFN34-20	YEXYY	AAT2845A1 ML-EE-T1



Skyworks Green™ products are compliant with all applicable legislation and are halogen-free.



For additional information, refer to *Skyworks Definition of Green™*, document number SQ04-0074.

Package Information³

TQFN34-20

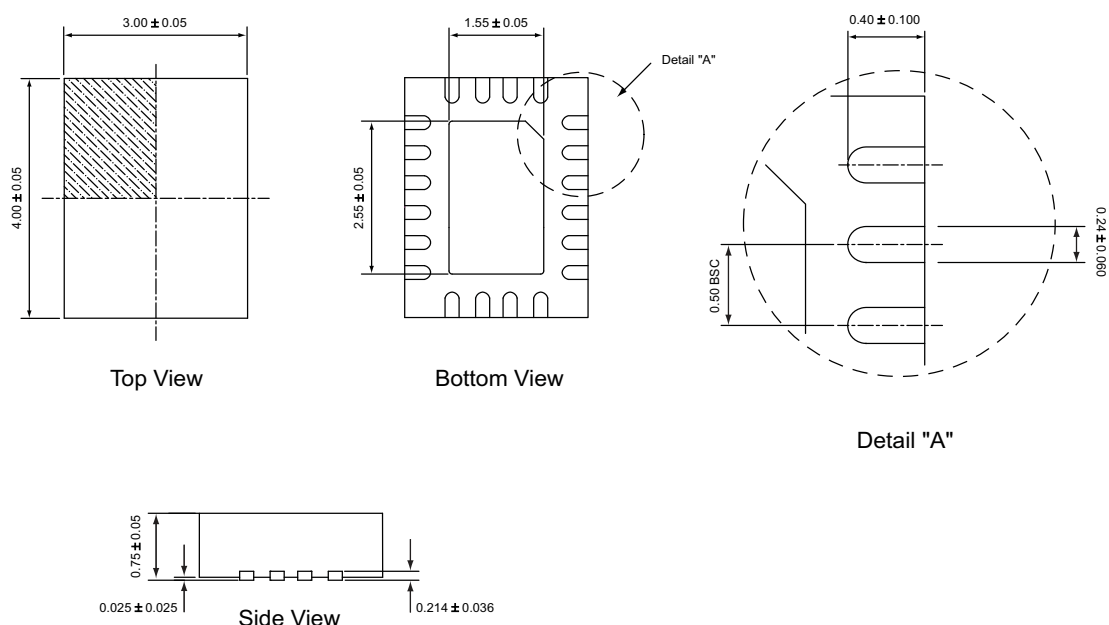

All dimensions in millimeters.

1. XYY = assembly and date code.
2. Sample stock is generally held on part numbers listed in BOLD.
3. The leadless package family, which includes QFN, TQFN, DFN, TDFN and STDFN, has exposed copper (unplated) at the end of the lead terminals due to the manufacturing process. A solder fillet at the exposed copper edge cannot be guaranteed and is not required to ensure a proper bottom solder connection.

Copyright © 2012 Skyworks Solutions, Inc. All Rights Reserved.

Information in this document is provided in connection with Skyworks Solutions, Inc. ("Skyworks") products or services. These materials, including the information contained herein, are provided by Skyworks as a service to its customers and may be used for informational purposes only by the customer. Skyworks assumes no responsibility for errors or omissions in these materials or the information contained herein. Skyworks may change its documentation, products, services, specifications or product descriptions at any time, without notice. Skyworks makes no commitment to update the materials or information and shall have no responsibility whatsoever for conflicts, incompatibilities, or other difficulties arising from any future changes.

No license, whether express, implied, by estoppel or otherwise, is granted to any intellectual property rights by this document. Skyworks assumes no liability for any materials, products or information provided hereunder, including the sale, distribution, reproduction or use of Skyworks products, information or materials, except as may be provided in Skyworks Terms and Conditions of Sale.

THE MATERIALS, PRODUCTS AND INFORMATION ARE PROVIDED "AS IS" WITHOUT WARRANTY OF ANY KIND, WHETHER EXPRESS, IMPLIED, STATUTORY, OR OTHERWISE, INCLUDING FITNESS FOR A PARTICULAR PURPOSE OR USE, MERCHANTABILITY, PERFORMANCE, QUALITY OR NON-INFRINGEMENT OF ANY INTELLECTUAL PROPERTY RIGHT; ALL SUCH WARRANTIES ARE HEREBY EXPRESSLY DISCLAIMED. SKYWORKS DOES NOT WARRANT THE ACCURACY OR COMPLETENESS OF THE INFORMATION, TEXT, GRAPHICS OR OTHER ITEMS CONTAINED WITHIN THESE MATERIALS. SKYWORKS SHALL NOT BE LIABLE FOR ANY DAMAGES, INCLUDING BUT NOT LIMITED TO ANY SPECIAL, INDIRECT, INCIDENTAL, STATUTORY, OR CONSEQUENTIAL DAMAGES, INCLUDING WITHOUT LIMITATION, LOST REVENUES OR LOST PROFITS THAT MAY RESULT FROM THE USE OF THE MATERIALS OR INFORMATION, WHETHER OR NOT THE RECIPIENT OF MATERIALS HAS BEEN ADVISED OF THE POSSIBILITY OF SUCH DAMAGE.

Skyworks products are not intended for use in medical, lifesaving or life-sustaining applications, or other equipment in which the failure of the Skyworks products could lead to personal injury, death, physical or environmental damage. Skyworks customers using or selling Skyworks products for use in such applications do so at their own risk and agree to fully indemnify Skyworks for any damages resulting from such improper use or sale.

Customers are responsible for their products and applications using Skyworks products, which may deviate from published specifications as a result of design defects, errors, or operation of products outside of published parameters or design specifications. Customers should include design and operating safeguards to minimize these and other risks. Skyworks assumes no liability for applications assistance, customer product design, or damage to any equipment resulting from the use of Skyworks products outside of stated published specifications or parameters.

Skyworks, the Skyworks symbol, and "Breakthrough Simplicity" are trademarks or registered trademarks of Skyworks Solutions, Inc., in the United States and other countries. Third-party brands and names are for identification purposes only, and are the property of their respective owners. Additional information, including relevant terms and conditions, posted at www.skyworksinc.com, are incorporated by reference.