

REVISONS		DATE	BY	APP'D
W	REVISED PER ECO-15-016062	09NOV15	KG	CD

- THIS PLUG IS DESIGNED TO CONFORM TO THE LATEST ISSUE OF MIL-C-24308.
 - MAX WIRE INSUL. TO BE USED WITH THIS PLUG IS .054 DIA.
 - METAL RETENTION CLIPS ARE INCLUDED IN INSERTS.
 - PACKAGE STAMPED M 24308/4-267F.
 - THIS PLUG WILL ACCEPT SIZE 22 PIN CONTACT M 39029/58-360 OR ANY TYCO HDD-22 PIN CONTACT
- ⑥ MFG'S PART NO. STAMPED ON CONNECTOR KIT NUMBER WITH CONTACTS FOR 204507-1 ONLY.
 - ⑦ UL/CSA DESIGNATION STAMPED IN THIS AREA, OPTIONAL.
 - ⑧ P/N'S 204507-4, -5, & 5--4 HAVE GROUNDING INDENTS ON FRONT SHELL, NOT SHOWN ON DRAWING.
 - ⑨ FINISH: BRIGHT TIN PER ASTM-B-545 .000400-.000550 THK OVER COPPER PER AMS2418, .000050 MIN THK.

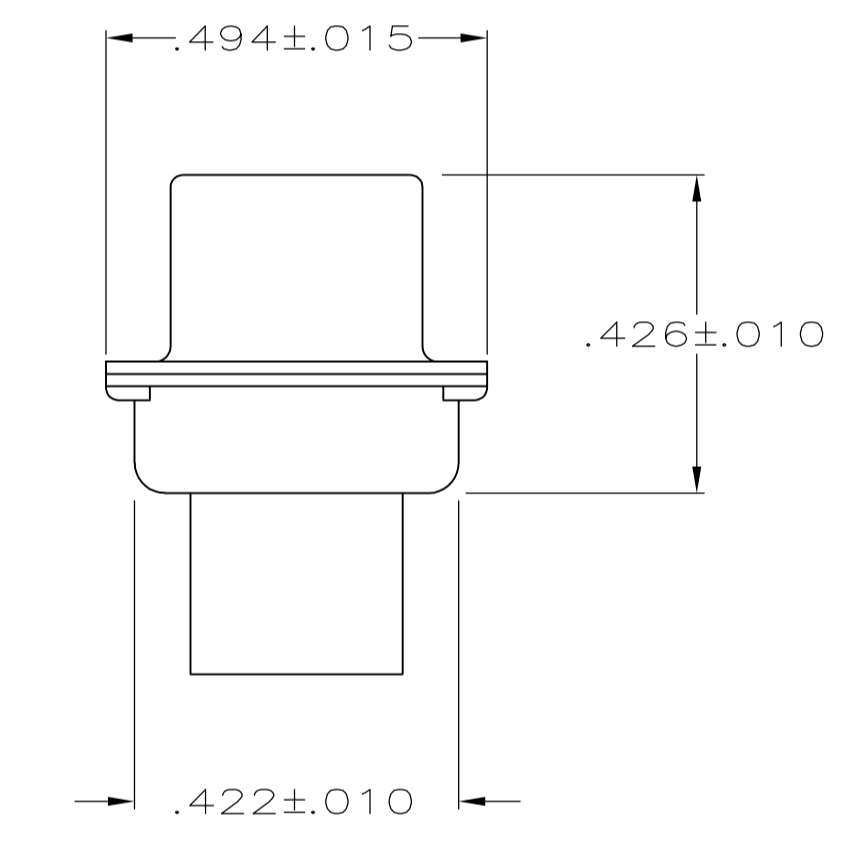
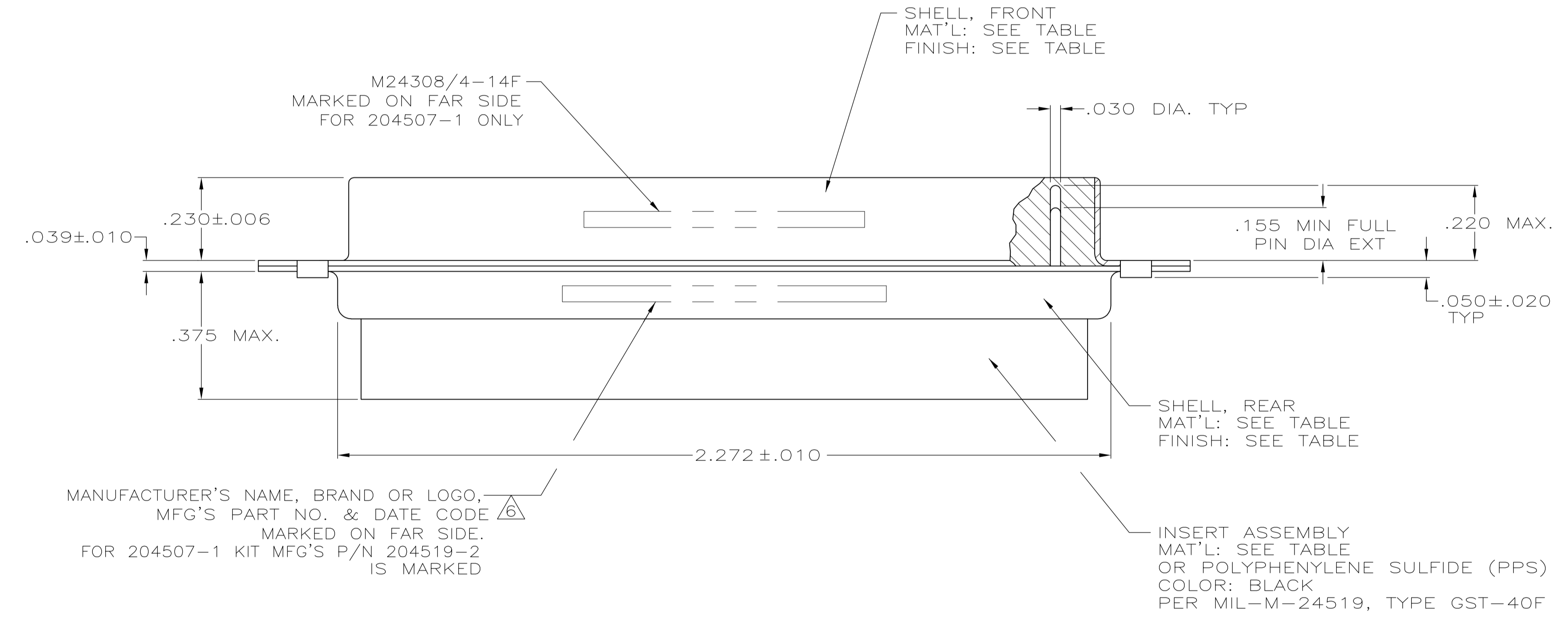
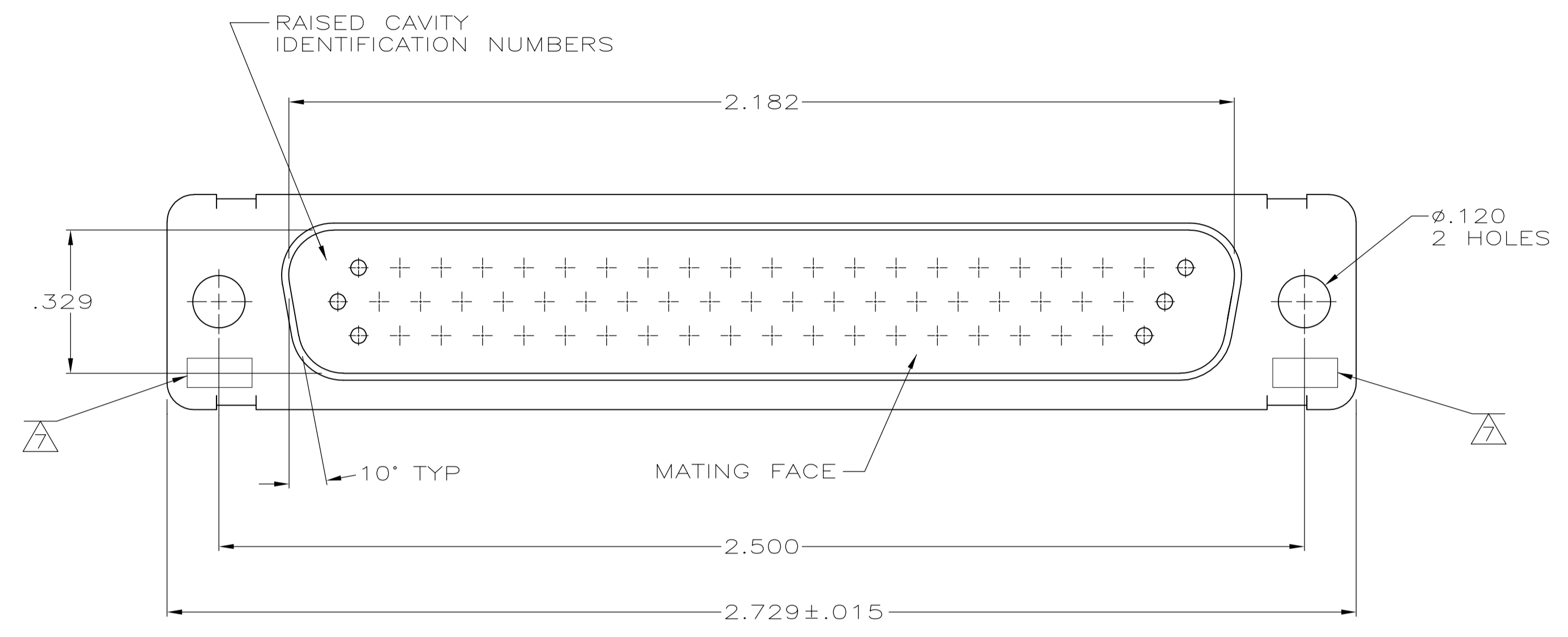

FINISH	SHELL MAT'L	INSERT MAT'L	PART NO.	
⑧ BRIGHT TIN PER ASTM-B-545	STEEL, CLASS G	GST-40F PER MIL-M-24519	5-204507-4	
⑨	STEEL, CLASS G	GST-40F PER MIL-M-24519	204507-6	
⑧	STEEL, CLASS G	GST-40F PER MIL-M-24519	204507-5	
⑧ BRIGHT TIN PER ASTM-B-545	STEEL, CLASS G	GST-40F PER MIL-M-24519	204507-4	
SUPSD BY 204507-1	CADMIUM PER QQ-P-416	STEEL, CLASS G	GST-40F PER MIL-M-24519	204507-3
SUPSD BY 206502-4	CADMIUM PER QQ-P-416	BRASS	GST-40F PER MIL-M-24519	204507-2
	CADMIUM PER QQ-P-416	STEEL, CLASS G	GST-40F PER MIL-M-24519	204507-1
	SHELL FINISH	SHELL MAT'L	INSERT MAT'L	PART NO.

THIS DRAWING IS A CONTROLLED DOCUMENT. DIMENSIONS: INCHES. TOLERANCES UNLESS OTHERWISE SPECIFIED: 0 PLC ± .005, 1 PLC ± .005, 2 PLC ± .005, 3 PLC ± .005, 4 PLC ± .005, ANGLES ± 0°30'.

APPROVED: F.C. BALLEW, 25JAN88. NAME: AMPLIMITE PLUG FOR PIN CONTACTS HI-DENSITY D CONNECTOR SIZE 4 (62 POSN) SERIES 90. SIZE: A1. WEIGHT: -. CUSTOMER DRAWING. SCALE: 4:1. SHEET: 1 OF 1. REV: W.

STE TE Connectivity