

DESCRIPTION

Demonstration circuit 524 is a positive input to negative output converter featuring the LTC3704 switching controller. The DC524 converts a 5V–15V input to a –5.2V output and provides up to 2.5A of output current from 5V input. The converter operates at 300kHz with a high efficiency of 89%. The DC524 is set to operate in No R_{SENSE} ™ mode with input voltages up to 15V. However, DC524 can be modified for higher input voltages with an optional current sense resistor. The circuit features optional soft-start circuitry that can be enabled or disabled with a single jumper. Also, DC524 has a jumper to program either continuous or Burst Mode™ operation. The DC524 can be synchronized to an external clock of up to

400kHz. Please refer to LTC3704 data sheet for design details and applications information.

The DC524 can produce up to 3A from a 5V input source, 4A from 10V source and 5A from 15V source. The actual current capability also depends on the operating temperature and available airflow. As MOSFET Q1 gets hot, its $R_{DS(ON)}$ increases and the available output current decreases.

Design files for this circuit board are available. Call the LTC factory.

Burst Mode is a registered trademark and No R_{SENSE} is a trademark of Linear Technology Corporation

Table 1. Performance Summary

PARAMETER	CONDITION	VALUE
Minimum Input Voltage		4.5V
Maximum Input Voltage	No R_{SENSE} mode	18V (or higher with some modifications)
V_{OUT}	$V_{IN} = 5V$ to 15V, $I_{OUT1} = 0A$ to 2.5A	–5.2V $\pm 3\%$
Typical Output Ripple V_{OUT}	$V_{IN} = 5V$ to 15V, $I_{OUT1} = 0A$ to 2.5	50mV _{P-P}
Nominal Switching Frequency		300kHz

QUICK START PROCEDURE

Demonstration circuit 524 is easy to set up to evaluate the performance of the LTC3704. Refer to Figure 1 for proper measurement equipment setup and follow the procedure below:

NOTE: When measuring the input or output voltage ripple, care must be taken to avoid a long ground lead on the oscilloscope probe. Measure the input or output voltage ripple by touching the probe tip directly across the V_{IN} or V_{OUT} and GND terminals. See Figure 2 for proper scope probe technique.

1. Place jumper JP1 in the ENABLE position.
2. With power off, connect the input power supply to V_{IN} and GND. Make sure that the input power supply has

sufficient current rating at minimum input voltage for the required output load.

3. Turn on the power at the input.

NOTE: Make sure that the input voltage does not exceed 15V.

4. Check for the proper output voltage: $V_{out} = -5.2V$

NOTE: If there is no output, temporarily disconnect the load to make sure that the load is not set too high.

5. Once the proper output voltage is established, adjust the load within the operating range and observe the output voltage regulation, ripple voltage, efficiency and other parameters.

QUICK START GUIDE FOR DEMONSTRATION CIRCUIT 524

POSITIVE INPUT TO NEGATIVE OUTPUT DC/DC CONVERTER

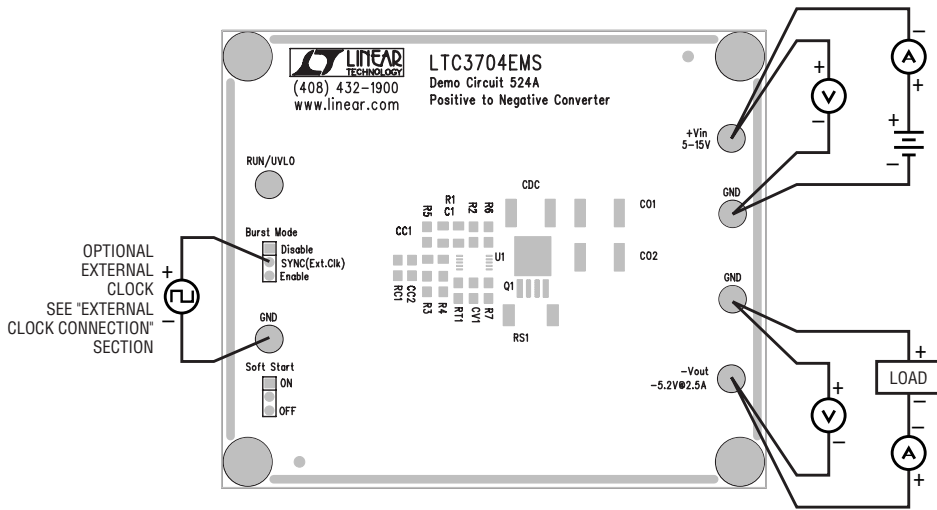

Figure 1. Proper Measurement Equipment Setup

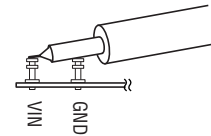

Figure 2. Scope Probe Placement for Measuring Input or Output Ripple

CONNECTING AN EXTERNAL CLOCK

1. Turn the input power source Off.
2. Remove the Burst Mode jumper.
3. Set the clock source pulse amplitude to 5V and set the frequency between 330 kHz and 400kHz.
4. Turn the clock source off.
5. Connect the clock source (pulse generator with TTL output) to the middle pin of Burst Mode jumper.
6. Apply input power and observe the switching frequency of 300kHz.
7. Turn the clock source on and observe the switching frequency go up to the switching frequency of the external clock.

USING AN OPTIONAL CURRENT SENSE RESISTOR

1. Refer to LTC3704 data sheet to determine the proper resistor value.
2. Replace current sense resistor Rs1 with the correct value.

3. Remove resistor R6.
4. Install 0Ω resistor R7.

MONITORING THE MOSFET CURRENT

Monitor the MOSFET current through the Rs1 resistor.

1. Connect a 50Ω coaxial cable across Rs1 with the shield connected to the ground connection of Rs1.
2. Use a 50Ω surface mount resistor to connect the center conductor of the coaxial cable to the Rs1 terminal which is connected to the source of MOSFET Q1.
3. Set the scope input to 50Ω and connect the coaxial cable to the scope.
4. Set the scope to 5mV/division or less. The current scale with 1mΩ Rs1 and 5mV/div is 10A/div (50Ω resistor at the input of coaxial cable forms 2:1 divider with 50Ω input impedance of scope).

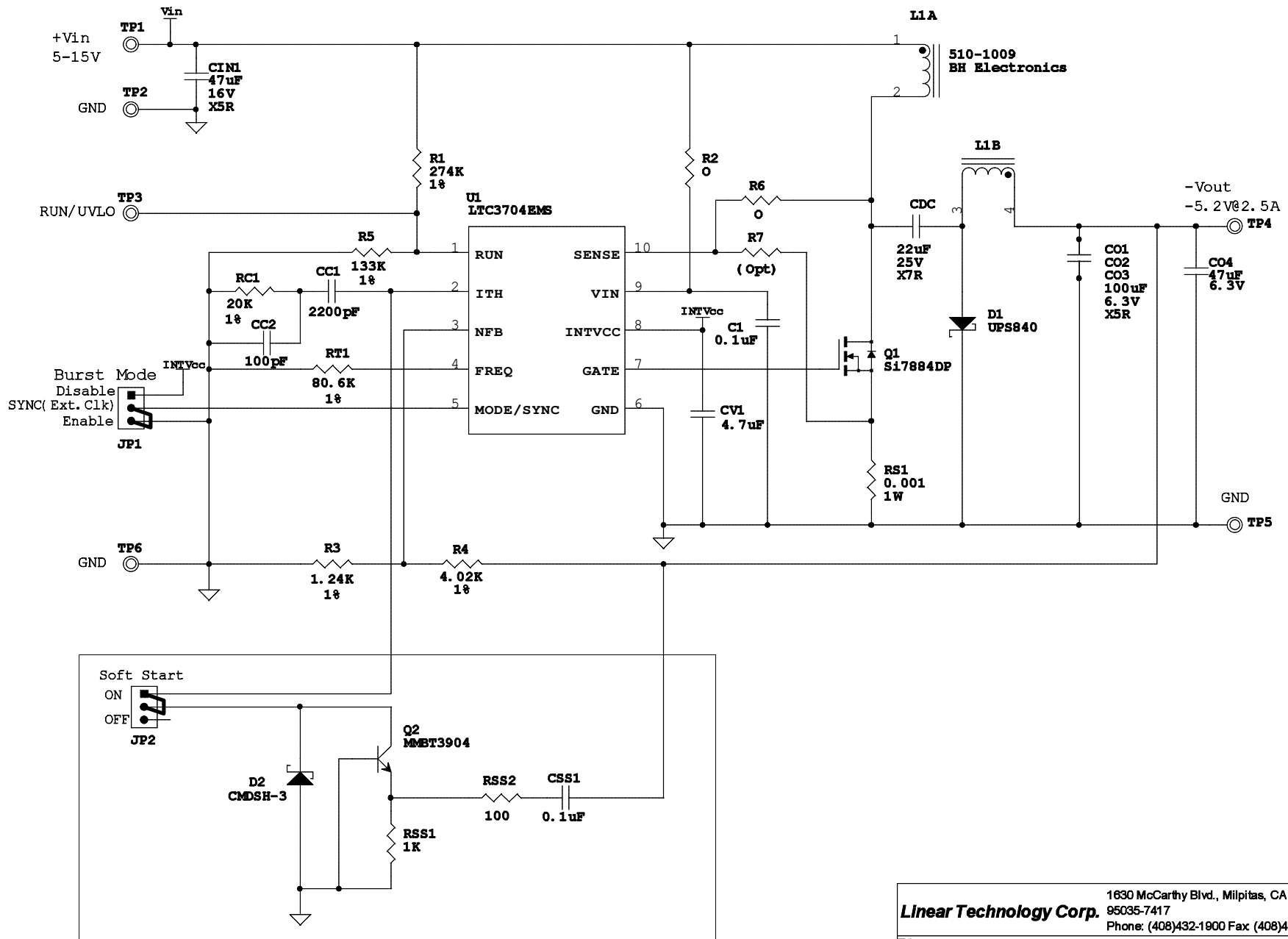

1630 McCarthy Blvd., Milpitas, CA Linear Technology Corp. 95035-7417 Phone: (408)432-1900 Fax: (408)434-0507		
Title LTC3704EMS (Positive to Negative Converter)		
Size	Document Number	Rev
	Demo Circuit 524	A
Date: Thursday, December 19, 2002 Sheet 1 of 1		

6/17/2005

Item	Qty	Reference	Part Description	Manufacture / Part #
1	1	CC1	CAP., X7R 2200pF 50V 10%	AVX 08055C222KAT1A
2	1	CC2	CAP., NPO, 100PF, 50V, 10%	AVX 08055A101KAT1A
3	1	CDC	CAP., X7R 22uF 25V 20%	TDK C5750X7R1E226M
4	1	CIN1	CAP., X5R 47uF 16V 20%	TDK C5750X5R1C476MT
5	3	CO1,CO2,CO3	CAP., X5R 100uF 6.3V 20%	Taiyo Yuden JMK432BJ107MU
6	1	CO4	CAP., X5R 47uF 6.3V 20%	TDK C4532X5R0J476M
7	1	CSS1	CAP., X7R, 0.1UF, 16V, 10%	AVX 0805YC104KAT2A
8	1	CV1	CAP., Y5V 4.7uF 10V 80%	AVX 0805ZG475ZAT1A
9	1	C1	CAP., X7R 0.1uF 25V 10%	AVX 08053C104KAT2A
10	1	D1	Schottky Rect., 40V/8Amp	Microsemi UPS840
11	1	D2	Schottky Diode, Super-Mini	Central Semi. Corp. CMDSH-3-LTC
12	2	JP1,JP2	Headers, 3 Pins 2mm Ctrs.	CommConn Con Inc. 2802S-03G2
13	2	XJP1,XJP2	Shunt, 2 Pins 2mm Ctrs.	CommConn Con Inc. CCIJ2MM-138G
14	1	L1	Dual Inductor, QTR-Pak	BH Electronics 510-1009
15	1	Q1	Mosfet N-Chan., PowerPAK SO-8	Vishay Siliconix Si7884DP
16	1	Q2	XSTR, NPN Small Sig.	Diodes Inc. MMBT3904-7
17	1	RC1	RES., Chip 20K 0.1W 1%	AAC CR10-2002FM
18	1	RSS1	RES., Chip 1K 0.1W 5%	AAC CR10-102JM
19	1	RSS2	RES., Chip 100 Ohms 0.1W 5%	AAC CR10-101JM
20	1	RS1	RES., Chip 0.001 1W 5%	Panasonic ERJM1WTJ1M0U
21	1	RT1	RES., Chip 80.6K 0.1W 1%	AAC CR10-8062FM
22	1	R1	RES., Chip 274K 0.1W 1%	AAC CR10-2743FM
23	2	R6,R2	Jumper, Chip 0 0.1W 5%	AAC CJ10-000M
24	1	R3	RES., CHIP, 1.24K, 0.1W, 1%	AAC CR10-1241FM
25	1	R4	RES., CHIP, 4.02K, 0.1W, 1%	AAC CR10-4021FM
26	1	R5	RES., Chip 133K 0.1W 1%	AAC CR10-1333FM
27	0	R7 (OPT)	Jumper, Chip 0 0.1W 5%	AAC CJ10-000M
28	6	TP1-TP6	Turret, Testpoint	Mill Max 2501-2
29	1	U1	I.C., NoRsense DC/DC Controller	Linear Tech. Corp. LTC3704EMS
30	4		SCREW, #4-40, 1/4"	ANY
31	4		STANDOFF, #4-40 1/2"	MICRO PLASTICS 14HTSP003
32	1		PRINTED CIRCUIT BOARD	DEMO CIRCUIT 524A
33	2		STENCIL	STENCIL 524A