

# P25 series

Rotary code switches



## DISTINCTIVE FEATURES

Lateral C-contact

SMJ, SMT-Pins

Contacts with hard gold plating

Solid, tinned PCB pins



## ENVIRONMENTAL SPECIFICATIONS

- Operating temperature: -50 °C to +125 °C (-58 °F to +257 °F)
- Storage temperature: -55 °C to +135 °C (-67 °F to +275 °F)
- Vibration, Shock : DIN EN 60068-2-6 and DIN EN 60068-2-27
- Humidity : 21 days at 40 °C (104 °F) 93% RH



## ELECTRICAL SPECIFICATIONS

- Operating voltage : 42 VDC max.
- Contact load, static : 400 mA max.
- Contact load, dynamic : 100 mA max.
- Initial contact resistance : 80 mΩ max.
- Insulation resistance : 100 MΩ min.



## MATERIALS

- Housing : plastic
- Cover : stainless steel
- Fixed contact, pins : copperalloy
- Moveable contacts : copperalloy
- Contact surface : hardgold
- Rotor: plastic



## SOLDERING

- Reflow soldering : 260 °C (500 °F) max. for 10 seconds max.

The company reserves the right to change specifications without notice.

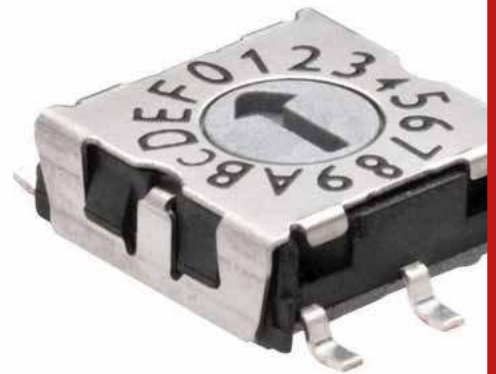

# P25 series

Rotary code switches



## BUILD YOUR PART NUMBER

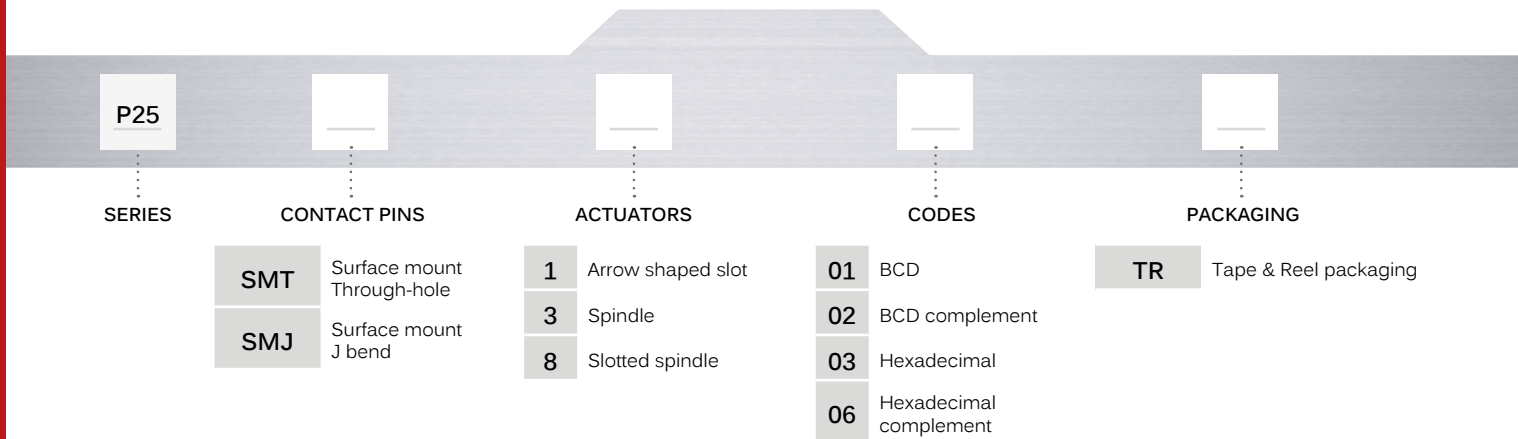

# P25 series

Rotary code switches

SMT

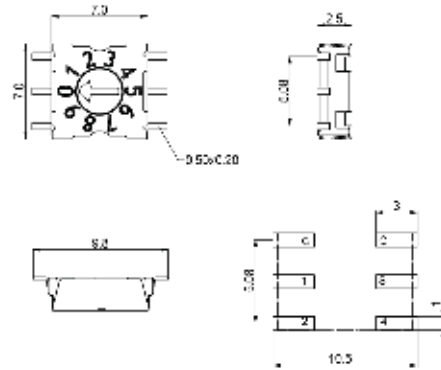

SMJ

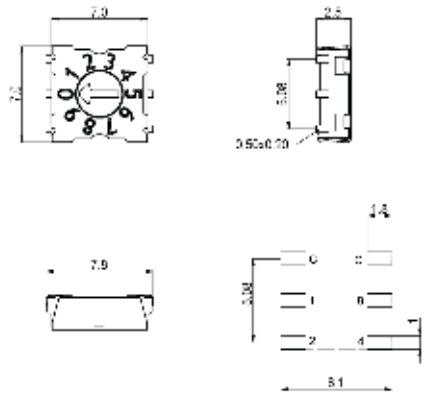

## ACTUATORS



- 1 Arrow shaped slot
- 3 Spindle
- 8 Slotted spindle



1

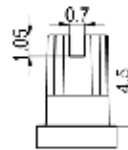

3

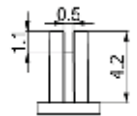

8

# P25 series

Rotary code switches

## CODES

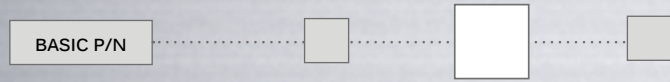

- 01 BCD
- 02 BCD complement
- 03 Hexadecimal
- 06 Hexadecimal complement



POSITION	C	1	2	4	8	MARKING
0	●					0
1	●	●				1
2	●		●			2
3	●	●	●			3
4	●			●		4
5	●	●		●		5
6	●		●	●		6
7	●	●	●	●		7
8	●				●	8
9	●	●			●	9

01

POSITION	C	1	2	4	8	MARKING
0	●	●	●	●	●	0
1	●		●	●	●	1
2	●	●		●	●	2
3	●			●	●	3
4	●	●	●		●	4
5	●		●		●	5
6	●	●			●	6
7	●				●	7
8	●	●	●	●		8
9	●		●	●		9

02

POSITION	C	1	2	4	8	MARKING
0	●					0
1	●	●				1
2	●		●			2
3	●	●	●			3
4	●			●		4
5	●	●		●		5
6	●		●	●		6
7	●	●	●	●		7
8	●				●	8
9	●	●			●	9
10	●		●		●	A
11	●	●	●		●	B
12	●			●	●	C
13	●	●		●	●	D
14	●		●	●	●	E
15	●	●	●	●	●	F

03

POSITION	C	1	2	4	8	MARKING
0	●					0
1	●	●				1
2	●		●			2
3	●			●		3
4	●	●			●	4
5	●		●		●	5
6	●	●			●	6
7	●				●	7
8	●	●	●	●		8
9	●		●	●		9
10	●	●		●		A
11	●			●		B
12	●	●	●			C
13	●		●			D
14	●	●				E
15	●					F

06

## PACKAGING

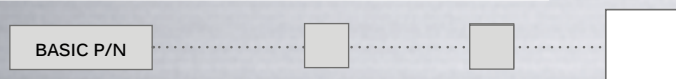

- (blank) Straight
- V Crimped (THR)
- L254 Right angle (THR)