

AG921-07E Digital Gear-Tooth Sensor Demonstrator

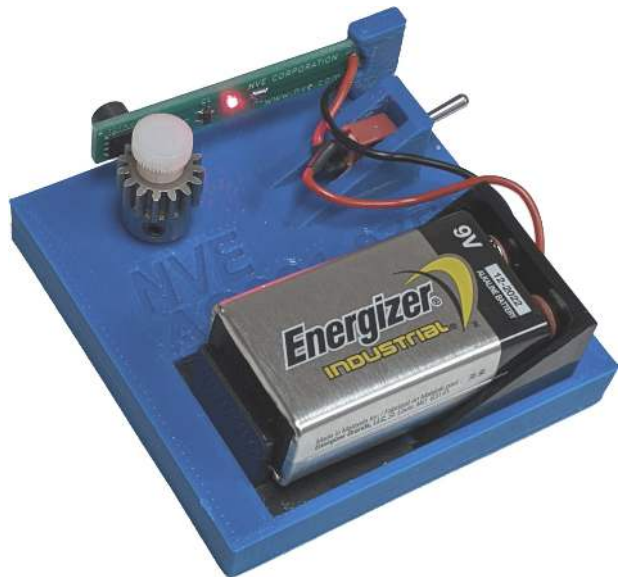

SN12454

About This Demonstrator

GT Sensors™ are designed to detect spindle gear teeth and magnetic encoder wheels in industrial speed sensing.

This demonstrator is based on an AKL-Series GT Sensor, which provides a 50% duty cycle digital current-modulated output.

The demonstrator also includes a circuit board with an LED and a transistor driver; a small gear that can be rotated; and a battery to power the circuit.

GT Sensors are based on Giant Magnetoresistance (GMR), providing the sensitivity to detect small gear teeth and wide air gaps. GT Sensors can operate to DC, and can therefore detect a wide range of speeds, including very slow speeds.

In addition to AKL-Series digital sensors, NVE offers ABL-Series analog gear-tooth sensors, which provide sinusoidal outputs. Single- or dual-bridge analog sensors are available. The dual-bridge versions have two out-of-phase outputs for determining direction.

For a demonstration: www.youtube.com/NveCorporation

Quick Start

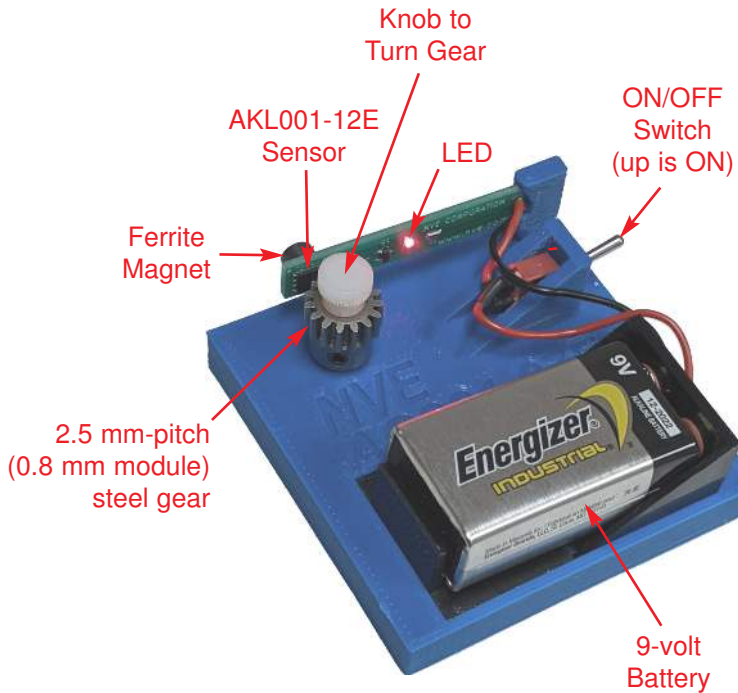

Quick Start

- Turn the demonstrator ON (switch in the up position).
- Turn the PCB to adjust the sensor-to-gear airgap if necessary.
- Turn the gear slowly and observe the LED tuning ON and OFF.
- Turn the demonstrator OFF after use to preserve battery life.

Note:

Style may vary from the above image.

Magnetic Operation

As shown in the diagrams at right, the direction of sensitivity is parallel to the plane of the AKL sensor. A biasing magnet provides magnetic field.

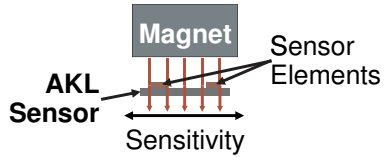

As the gear turns, the magnetic flux lines are deflected into the direction of sensitivity by passing steel gear teeth.

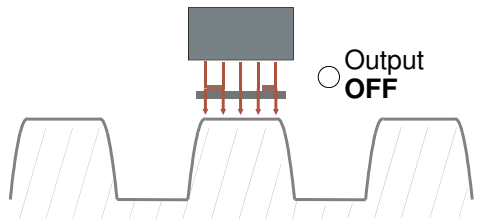

The sensor produces a digital output with one cycle per tooth.

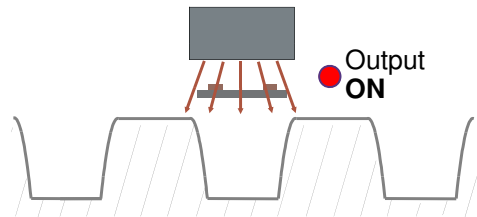

Magnetic Design Considerations

The Right Sensor for the Application

AKL-Series sensors have two sensor elements with various spacings. The following table shows popular models:

Part No.	Element Spacing	Recommended Gear Pitch	Recommended Gear Module
AKL001-12E*	1 mm	1.7 – 6 mm	0.5 – 2 mm
AKL002-12E	0.5 mm	0.8 – 1.7 mm	0.25 – 0.5 mm
AKL003-12E	0.3 mm	0.5 – 0.8 mm	0.16 – 0.25 mm

*Included in the demonstrator

The best design margin is when the sensor element spacing is equal to approximately one-half the gear pitch. In this demonstrator, the gear pitch is approximately 2.5 mm, so the 1 mm sensor (AKL001) is used.

Sensor-to-Magnet Spacing

This demonstrator has the sensor and magnet on opposite sides of a circuit board, providing approximately 1.5 millimeter spacing between the sensor and magnet. The AKL001 airgap range is typically 1 to 3.5 mm.

Magnet Selection

Ferrite magnets, like the NVE number 12216 disk magnet used in this demonstrator, are recommended for most gear-tooth applications because of their low cost and good field properties. Alnico-8 magnets can be used for high-temperature applications. Care should be taken using rare-earth magnets to avoid saturating the sensors.

Design Support

Check out our free Web application for GT sensor design support:
<https://www.nve.com/spec/calculators.php#tabs-GT-Sensor-Output>

Schematic and Electrical Operation

Demonstrator Circuitry

AKL-Series Gear-Tooth Sensors have 4-to-8 mA two-wire interfaces. This demonstrator uses a circuit board with an LED and transistor driver.

When the sensor current is 4 mA, the voltage across the 100 ohm resistor is 0.4 V, which is not enough to turn on the transistor. With 8 mA the transistor turns on, illuminating the LED.

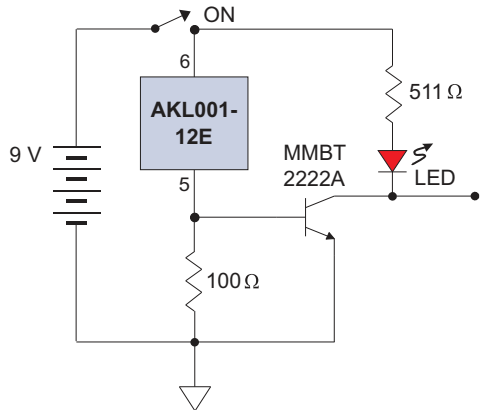

Demonstrator Schematic

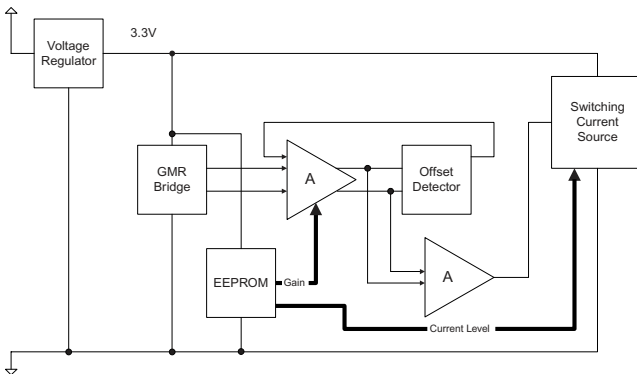

AKL-Series Sensor Block Diagram

AKL Operation

AKL-Series sensors include a GMR bridge consisting of two GMR sensor elements, a voltage regulator to allow a wide range of supply voltages, a factory-programmable EEPROM for calibration, and an output driver.

Circuit Board

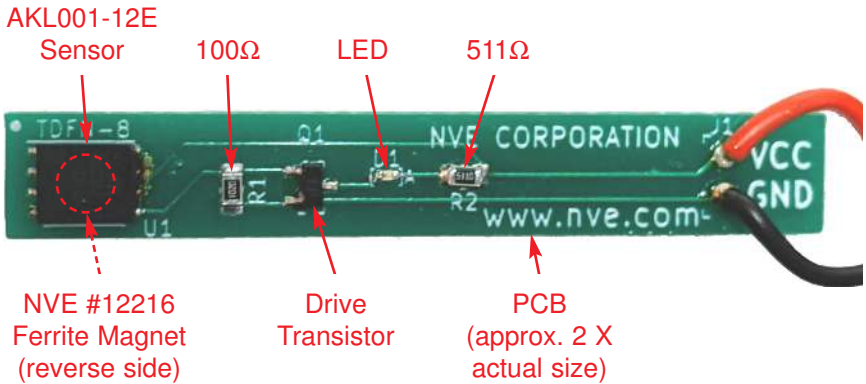

For more information: www.nve.com/Downloads/gtsensor_catalog.pdf

Limited Warranty and Liability

Information in this document is believed to be accurate and reliable. However, NVE does not give any representations or warranties, expressed or implied, as to the accuracy or completeness of such information and shall have no liability for the consequences of use of such information. In no event shall NVE be liable for any indirect, incidental, punitive, special or consequential damages (including, without limitation, lost profits, lost savings, business interruption, costs related to the removal or replacement of any products or rework charges) whether or not such damages are based on tort (including negligence), warranty, breach of contract or any other legal theory.

Right to Make Changes

NVE reserves the right to make changes to information published in this document including, without limitation, specifications and product descriptions at any time and without notice.

Use in Life-Critical or Safety-Critical Applications

Unless NVE and a customer explicitly agree otherwise in writing, NVE products are not designed, authorized or warranted to be suitable for use in life support, life-critical or safety-critical devices or equipment. NVE accepts no liability for inclusion or use of NVE products in such applications and such inclusion or use is at the customer's own risk. Should the customer use NVE products for such application whether authorized by NVE or not, the customer shall indemnify and hold NVE harmless against all claims and damages.

Applications

Applications described in this document are illustrative only. NVE makes no representation or warranty that such applications will be suitable for the specified use without further testing or modification. Customers are responsible for the design and operation of their applications and products using NVE products, and NVE accepts no liability for any assistance with applications or customer product design. It is customer's sole responsibility to determine whether the NVE product is suitable and fit for the customer's applications and products planned, as well as for the planned application and use of customer's third party customers. Customers should provide appropriate design and operating safeguards to minimize the risks associated with their applications and products. NVE does not accept any liability related to any default, damage, costs or problem which is based on any weakness or default in the customer's applications or products, or the application or use by customer's third party customers. The customer is responsible for all necessary testing for the customer's applications and products using NVE products in order to avoid a default of the applications and the products or of the application or use by customer's third party customers. NVE accepts no liability in this respect.

An ISO 9001 Certified Company

NVE Corporation
11409 Valley View Road
Eden Prairie, MN 55344-3617

©NVE Corporation

All rights are reserved. Reproduction in whole or in part is prohibited without the prior written consent of the copyright owner.

Manual No.: SB-00-046, rev. 4/13/21