

## Product Brief

# TLE4957C

Highly accurate differential Hall sensor with visible adaptive hysteresis and high vibration robustness for automotive powertrain and industrial applications

The TLE4957C family detects the motion and position of ferromagnetic structures by measuring the change of differential flux density which results from a moving magnetic encoder wheel or is generated by the interaction of a magnetic back bias field with the ferromagnetic structure of a gear wheel or similar structure. The high sensitivity and self-calibration mode ensure optimal measurement accuracy. The sensor powers up very fast and reaches full calibration within only a few transitions after start-up. The combination of a frequent recalibration function in run mode with its visible or hidden adaptive hysteresis algorithm enables the TLE4957C to accurately switch over a broad range of different gear wheel structures with a high robustness against disturbances, like air-gap jumps or run-out events. TLE4957 has a voltage interface with a PWM output signal, therefore it comes with a 3-wire output, but a 2-wire configuration is possible by using 2 resistors.

In order to perfectly meet the requirements of harsh environmental conditions prevalent in automotive applications, the sensor is designed to withstand a wide range of temperatures, is robust against vibration, has a high ESD performance and large EMC resistance. With its features TLE4957C family is the ideal differential Hall sensor for applications like today's crankshaft or transmission speed sensing in automotive, speedometers or similar industrial applications.

TLE4957C is perfectly suited for applications like:

### Gear Wheel Application with Back Bias Magnet and Magnetic Encoder Wheel Application

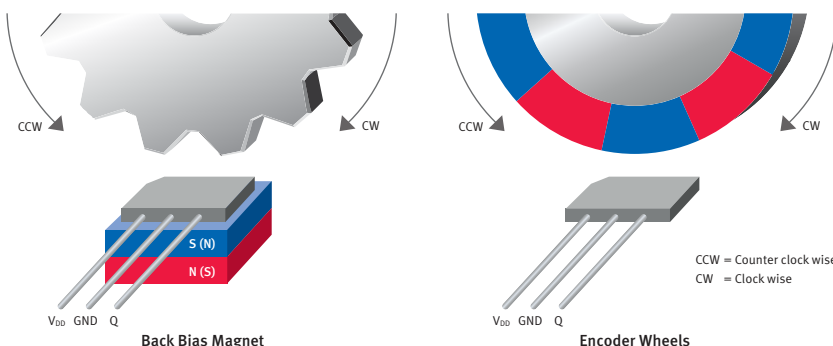

### Features

- High sensitivity
- Adaptive thresholds
- Visible and hidden hysteresis options
- Large operating air-gap
- Advanced performance by dynamic self calibration principle
- Wide frequency range of 1Hz to 8kHz
- Digital output signal
- Wide operating temperature ranges of  $-40^{\circ}\text{C} \leq T_j \leq +175^{\circ}\text{C}$
- Reverse voltage protection at  $V_{S-pin}$
- Short-circuit and overtemperature protection of output
- Module style package with two integrated capacitors:
  - 4.7nF between Q and GND
  - 47nF between  $V_S$  and GND:
 Required for micro cuts in power supply and optimal EMC robustness



# TLE4957C

Highly accurate differential Hall sensor with visible adaptive hysteresis and high vibration robustness for automotive powertrain and industrial applications

## Block Diagram

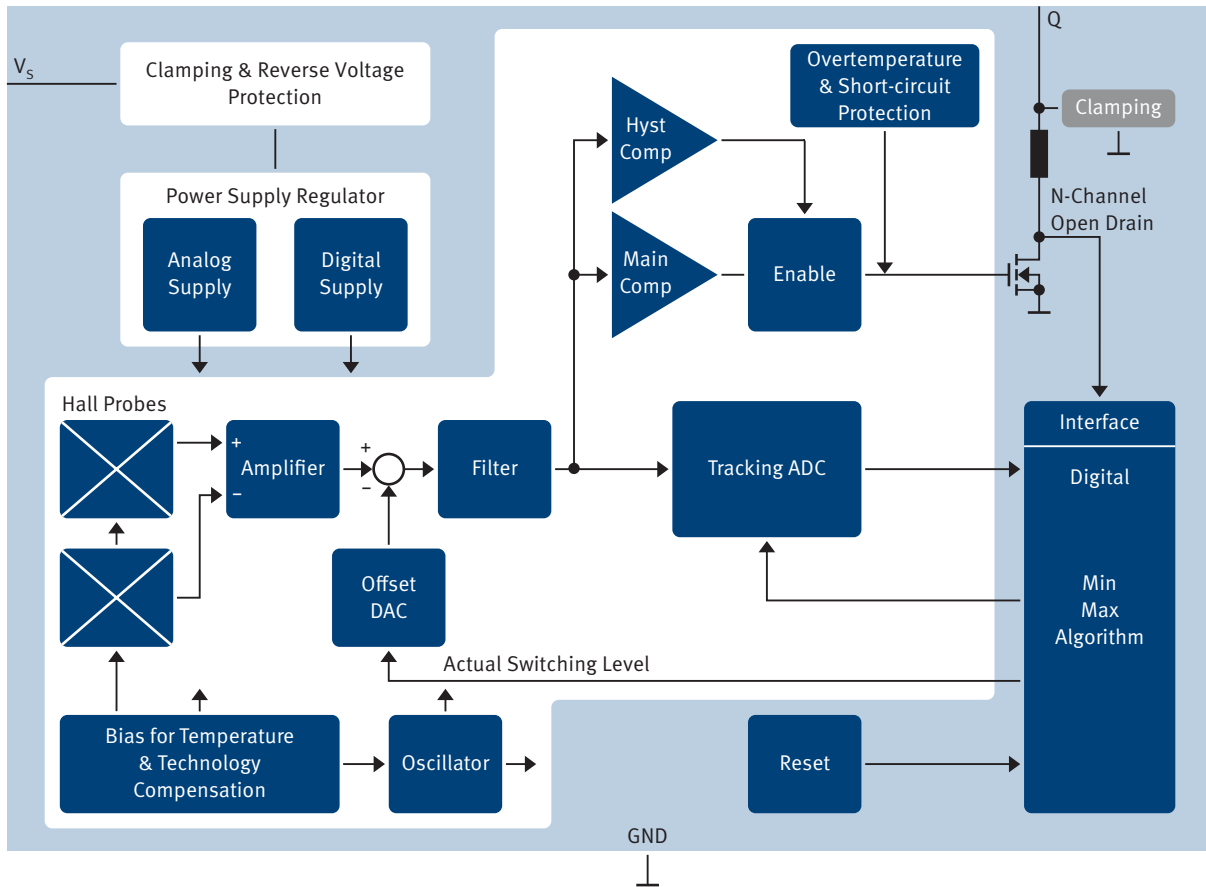

Sales Name	Description	Order Code
TLE4957C E6747	TLE4957 hidden adaptive hysteresis in PG-SSO-3-92 package	SP000649296
TLE4957C-2 E6747	TLE4957 visible adaptive hysteresis in PG-SSO-3-92 package	SP000745374

Published by  
Infineon Technologies AG  
85579 Neubiberg, Germany

© 2013 Infineon Technologies AG.  
All Rights Reserved.

Visit us:  
[www.infineon.com](http://www.infineon.com)

Order Number: B142-H9823-X-X-7600  
Date: 09 / 2013

### Attention please!

The information given in this document shall in no event be regarded as a guarantee of conditions or characteristics ("Beschaffenheitsgarantie"). With respect to any examples or hints given herein, any typical values stated herein and/or any information regarding the application of the device, Infineon Technologies hereby disclaims any and all warranties and liabilities of any kind, including without limitation warranties of non-infringement of intellectual property rights of any third party.

### Information

For further information on technology, delivery terms and conditions and prices please contact your nearest Infineon Technologies Office ([www.infineon.com](http://www.infineon.com)).

### Warnings

Due to technical requirements components may contain dangerous substances. For information on the types in question please contact your nearest Infineon Technologies Office. Infineon Technologies Components may only be used in life-support devices or systems with the express written approval of Infineon Technologies, if a failure of such components can reasonably be expected to cause the failure of that life-support device or system, or to affect the safety or effectiveness of that device or system. Life support devices or systems are intended to be implanted in the human body, or to support and/or maintain and sustain and/or protect human life. If they fail, it is reasonable to assume that the health of the user or other persons may be endangered.