

LEAD FREE CONVERSION EC NO: UCP2013-4288 DRAWN: RWHIPPLE 2013/04/09 CHKD: MWOLFE 2013/04/09 APPR: SMILLER 2013/08/26	QUALITY SYMBOLS ▽=0 ▽=0 ▽=0	GENERAL TOLERANCES (UNLESS SPECIFIED)		DIMENSION STYLE MM ONLY		SCALE 3:1	DESIGN UNITS METRIC	THIRD ANGLE PROJECTION	
		4 PLACES ± --- ± ---	3 PLACES ± --- ± ---	2 PLACES ± 0.13 ± ---	1 PLACE ± 0.25 ± ---	0 PLACE ± ±	DRAWN BY DATE BPISZCZOR 2007/02/28		CHECKED BY DATE JLAURX 2007/02/28
REVISIONS	DESCRIPTION	ANGULAR ±1/2°		MATERIAL NO.		DOCUMENT NO.		SHEET NO.	
		DRAFT WHERE APPLICABLE MUST REMAIN WITHIN DIMENSIONS		SEE CHART		SD-76035-004		1 OF 4	
THIS DRAWING CONTAINS INFORMATION THAT IS PROPRIETARY TO MOLEX INCORPORATED AND SHOULD NOT BE USED WITHOUT WRITTEN PERMISSION									

76035-****

MODULE TYPE -- TAIL PLATING TYPE
 GUIDE RIGHT -- MATTE TIN (FORMERLY TIN/LEAD) = 4
 GUIDE RIGHT -- MATTE TIN = 5
 GUIDE RIGHT W/END WALL -- MATTE TIN (FORMERLY TIN/LEAD) = 8
 GUIDE RIGHT W/END WALL -- MATTE TIN = 9

OF COLUMNS
 8 = 8 COL
 9 = 9 COL
 1 = 10 COL

KEY ORIENTATION
 0 = NO KEY
 1 = A
 2 = B
 3 = C
 4 = D
 5 = E
 6 = F
 7 = G
 8 = H

PIN LENGTH (P)
 2 = 3.90 - 30 GOLD
 3 = 4.70 - 30 GOLD
 4 = 5.70 - 30 GOLD
 5 = 4.70 & 5.70 - 30 GOLD STAGGERED
 6 = 3.90 - 10 GOLD
 7 = 4.70 - 10 GOLD
 8 = 5.70 - 10 GOLD
 9 = 4.70 & 5.70 - 10 GOLD STAGGERED

MATERIAL NUMBER	# OF COLUMNS	DIM "A"	DIM "B"
76035-48**	8	35.9	25.90
76035-49**	9	39.6	29.60
76035-41**	10	43.3	33.30
76035-51**	8	35.9	25.90
76035-59**	9	39.6	29.60
76035-51**	10	43.3	33.30

GUIDE RIGHT STYLE

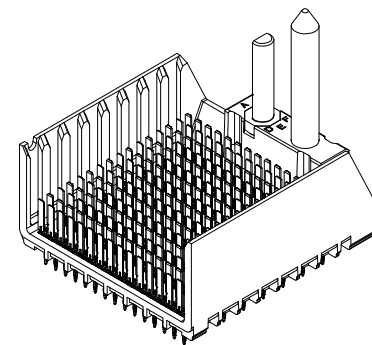

MATERIAL NUMBER	# OF COLUMNS	DIM "A"	DIM "B"
76035-88**	8	37.2	25.90
76035-89**	9	40.9	29.60
76035-81**	10	44.6	33.30
76035-98**	8	37.2	25.90
76035-99**	9	40.9	29.60
76035-91**	10	44.6	33.30

GUIDE RIGHT W/END WALL STYLE

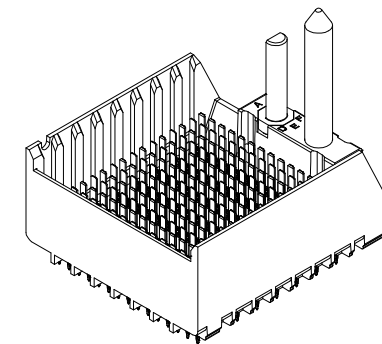

SEE SHEET 1 EC NO: UCP2013-4288 DRW: RMH/PPLE 2013/04/09 CHK: MWOLFE 2013/04/09 APPR: SMILLER 2013/08/26	QUALITY SYMBOLS ▽=0 ▽=0 ▽=0	GENERAL TOLERANCES (UNLESS SPECIFIED)		DIMENSION STYLE MM ONLY		SCALE 4:1	DESIGN UNITS METRIC	THIRD ANGLE PROJECTION		
		4 PLACES ± --- ± ---	3 PLACES ± --- ± ---	2 PLACES ± 0.13 ± ---	1 PLACE ± 0.25 ± ---	0 PLACE ± ±	DRAWN BY DATE BPISZCZOR 2007/02/28	I-TRAC 15 ROW BP GUIDE RIGHT ASSEMBLY SALES DRAWING		
		ANGULAR ±1/2°		DRAFT WHERE APPLICABLE MUST REMAIN WITHIN DIMENSIONS		APPROVED BY DATE CBIXLER 2007/02/28	molex			
		SEE CHART				MATERIAL NO. SD-76035-004	DOCUMENT NO.	SHEET NO. 2 OF 4		

THIS DRAWING CONTAINS INFORMATION THAT IS PROPRIETARY TO MOLEX INCORPORATED AND SHOULD NOT BE USED WITHOUT WRITTEN PERMISSION

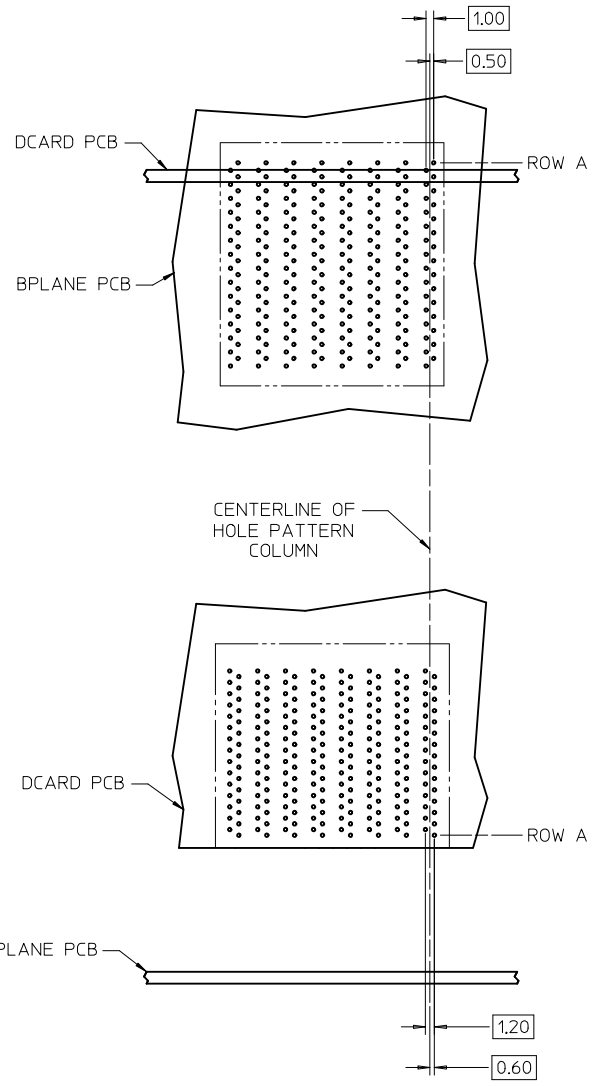

15 ROW I-TRAC BOARD RELATIONSHIPS

SCALE 2:1

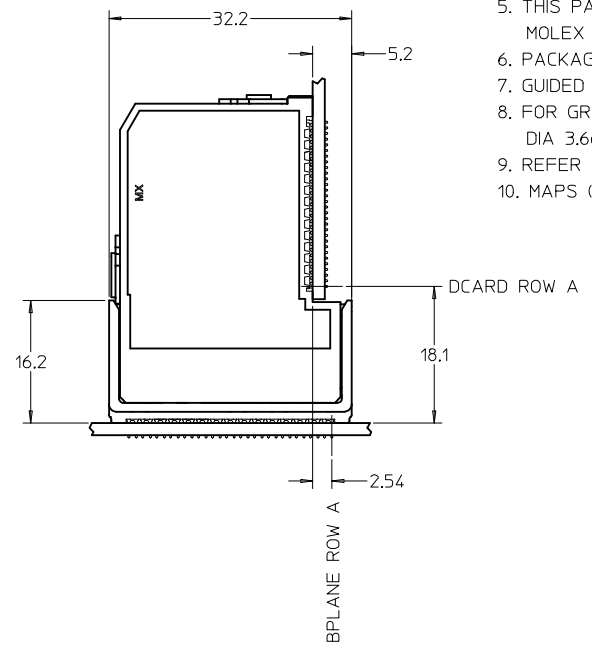

NOTES:

1. MATERIALS: HOUSING - LIQUID CRYSTAL POLYMER (LCP)
GLASS-FILLED, UL94V-0
TERMINALS - HIGH PERFORMANCE COPPER ALLOY
2. FINISH: 10 MICROINCH MIN.(MAPS) GOLD OR 30 MICROINCH MIN. GOLD
IN CONTACT AREA. SELECTIVE MATTE TIN ON PCB TAILS, NICKEL OVERALL.
3. REFER TO MOLEX PRODUCT SPECIFICATION PS-75710-999
FOR PERFORMANCE SPECIFICATIONS.
4. FOR MIXED CONTACT MATING LENGTHS, CONSULT MOLEX
FOR AVAILABILITY.
5. THIS PART CONFORMS TO CLASS B REQUIREMENTS OF
MOLEX COSMETIC SPEC PS-45499-002.
6. PACKAGE PER: PK-70873-586.
7. GUIDED PARTS TO BE SHIPPED WITH 2-56 UNC B SCREW P/N 73774-1000.
8. FOR GROUNDED GUIDE PINS USE DIA 3.56+/-0.08 (PTH),
DIA 3.66 (DRILL), AND DIA 6.5 (PAD).
9. REFER TO PCB ROUTING GUIDE FOR ANTIPAD AND ROUTING RECOMMENDATIONS.
10. MAPS (MOLEX ADVANCED PLATING SYSTEM).

SEE SHEET 1 EC NO: UCP2013-4288 DRW:RWHIPPLE 2013/04/09 CHKD:MMOLFE 2013/04/09 APPR:SMILLER 2013/08/26	QUALITY SYMBOLS ▽=0 ▽=0 ▽=0	GENERAL TOLERANCES (UNLESS SPECIFIED) <table border="1"> <tr> <th></th> <th>mm</th> <th>INCH</th> </tr> <tr> <td>4 PLACES</td> <td>± ---</td> <td>± ---</td> </tr> <tr> <td>3 PLACES</td> <td>± ---</td> <td>± ---</td> </tr> <tr> <td>2 PLACES</td> <td>± 0.13</td> <td>± ---</td> </tr> <tr> <td>1 PLACE</td> <td>± 0.25</td> <td>± ---</td> </tr> <tr> <td>0 PLACE</td> <td>±</td> <td>±</td> </tr> </table>		mm	INCH	4 PLACES	± ---	± ---	3 PLACES	± ---	± ---	2 PLACES	± 0.13	± ---	1 PLACE	± 0.25	± ---	0 PLACE	±	±	DIMENSION STYLE MM ONLY DRAWN BY DATE BPISZCZOR 2007/02/28 CHECKED BY DATE JLAURX 2007/02/28 APPROVED BY DATE CBIXLER 2007/02/28	SCALE 4:1 DESIGN UNITS METRIC THIRD ANGLE PROJECTION	TITLE I-TRAC 15 ROW BP GUIDE RIGHT ASSEMBLY SALES DRAWING molex DOCUMENT NO. SD-76035-004 SHEET NO. 3 OF 4
		mm	INCH																				
	4 PLACES	± ---	± ---																				
	3 PLACES	± ---	± ---																				
2 PLACES	± 0.13	± ---																					
1 PLACE	± 0.25	± ---																					
0 PLACE	±	±																					
DRAFT WHERE APPLICABLE MUST REMAIN WITHIN DIMENSIONS	MATERIAL NO. SEE CHART	THIS DRAWING CONTAINS INFORMATION THAT IS PROPRIETARY TO MOLEX INCORPORATED AND SHOULD NOT BE USED WITHOUT WRITTEN PERMISSION																					
ANGULAR ±1/2°	SIZE C																						

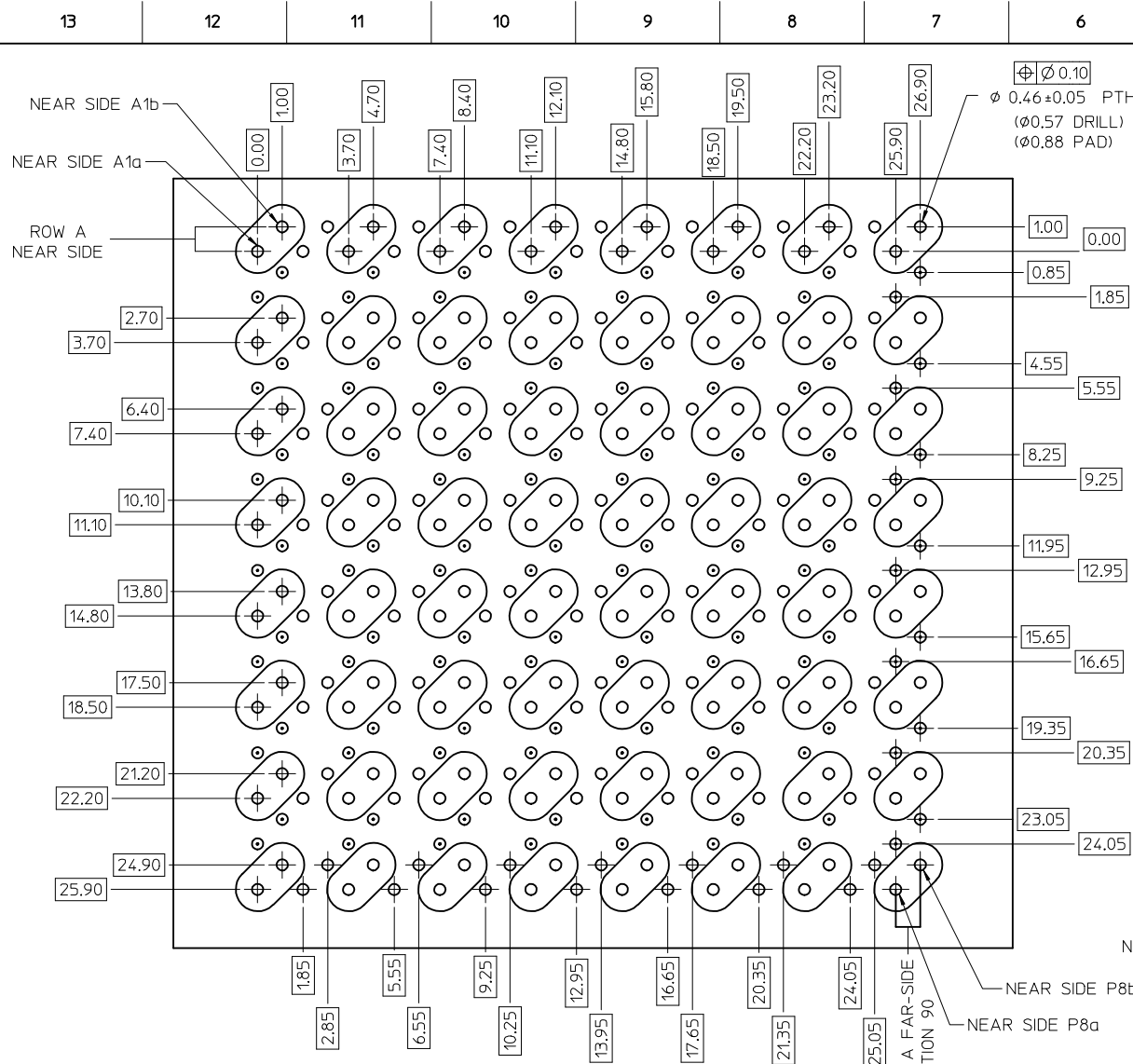

Orthogonal PCB Layout

NOTES:

- SIGNAL PAIRS (SHARED VIAS)
- NEAR SIDE GROUNDS
- FAR SIDE GROUNDS

ORTHO PIN MAPPING							
OPTION 90 (NEAR SIDE - FAR SIDE)							
A1b-P8b	A2b-N8b	A3b-L8b	A4b-J8b	A5b-G8b	A6b-E8b	A7b-C8b	A8b-A8b
A1a-P8a	A2a-N8a	A3a-L8a	A4a-J8a	A5a-G8a	A6a-E8a	A7a-C8a	A8a-A8a
C1b-P7b	C2b-N7b	C3b-L7b	C4b-J7b	C5b-G7b	C6b-E7b	C7b-C7b	C8b-A7b
C1a-P7a	C2a-N7a	C3a-L7a	C4a-J7a	C5a-G7a	C6a-E7a	C7a-C7a	C8a-A7a
E1b-P6b	E2b-N6b	E3b-L6b	E4b-J6b	E5b-G6b	E6b-E6b	E7b-C6b	E8b-A6b
E1a-P6a	E2a-N6a	E3a-L6a	E4a-J6a	E5a-G6a	E6a-E6a	E7a-C6a	E8a-A6a
G1b-P5b	G2b-N5b	G3b-L5b	G4b-J5b	G5b-G5b	G6b-E5b	G7b-C5b	G8b-A5b
G1a-P5a	G2a-N5a	G3a-L5a	G4a-J5a	G5a-G5a	G6a-E5a	G7a-C5a	G8a-A5a
I1b-P4b	I2b-N4b	I3b-L4b	I4b-J4b	I5b-G4b	I6b-E4b	I7b-C4b	I8b-A4b
I1a-P4a	I2a-N4a	I3a-L4a	I4a-J4a	I5a-G4a	I6a-E4a	I7a-C4a	I8a-A4a
L1b-P3b	L2b-N3b	L3b-L3b	L4b-J3b	L5b-G3b	L6b-E3b	L7b-C3b	L8b-A3b
L1a-P3a	L2a-N3a	L3a-L3a	L4a-J3a	L5a-G3a	L6a-E3a	L7a-C3a	L8a-A3a
N1b-P2b	N2b-N2b	N3b-L2b	N4b-J2b	N5b-G2b	N6b-E2b	N7b-C2b	N8b-A2b
N1a-P2a	N2a-N2a	N3a-L2a	N4a-J2a	N5a-G2a	N6a-E2a	N7a-C2a	N8a-A2a
P1b-P1b	P2b-N1b	P3b-L1b	P4b-J1b	P5b-G1b	P6b-E1b	P7b-C1b	P8b-A1b
P1a-P1a	P2a-N1a	P3a-L1a	P4a-J1a	P5a-G1a	P6a-E1a	P7a-C1a	P8a-A1a

ORTHO PIN MAPPING							
OPTION 270 (NEAR SIDE - FAR SIDE)							
A1b-A1a	A2b-C1a	A3b-E1a	A4b-G1a	A5b-J1a	A6b-L1a	A7b-N1a	A8b-P1a
A1a-A1b	A2a-C1b	A3a-E1b	A4a-G1b	A5a-J1b	A6a-L1b	A7a-N1b	A8a-P1b
C1b-A2a	C2b-C2a	C3b-E2a	C4b-G2a	C5b-J2a	C6b-L2a	C7b-N2a	C8b-P2a
C1a-A2b	C2a-C2b	C3a-E2b	C4a-G2b	C5a-J2b	C6a-L2b	C7a-N2b	C8a-P2b
E1b-A3a	E2b-C3a	E3b-E3a	E4b-G3a	E5b-J3a	E6b-L3a	E7b-N3a	E8b-P3a
E1a-A3b	E2a-C3b	E3a-E3b	E4a-G3b	E5a-J3b	E6a-L3b	E7a-N3b	E8a-P3b
G1b-A4a	G2b-C4a	G3b-E4a	G4b-G4a	G5b-J4a	G6b-L4a	G7b-N4a	G8b-P4a
G1a-A4b	G2a-C4b	G3a-E4b	G4a-G4b	G5a-J4b	G6a-L4b	G7a-N4b	G8a-P4b
J1b-A5a	J2b-C5a	J3b-E5a	J4b-G5a	J5b-J5a	J6b-L5a	J7b-N5a	J8b-P5a
J1a-A5b	J2a-C5b	J3a-E5b	J4a-G5b	J5a-J5b	J6a-L5b	J7a-N5b	J8a-P5b
L1b-A6a	L2b-C6a	L3b-E6a	L4b-G6a	L5b-J6a	L6b-L6a	L7b-N6a	L8b-P6a
L1a-A6b	L2a-C6b	L3a-E6b	L4a-G6b	L5a-J6b	L6a-L6b	L7a-N6b	L8a-P6b
N1b-A7a	N2b-C7a	N3b-E7a	N4b-G7a	N5b-J7a	N6b-L7a	N7b-N7a	N8b-P7a
N1a-A7b	N2a-C7b	N3a-E7b	N4a-G7b	N5a-J7b	N6a-L7b	N7a-N7b	N8a-P7b
P1b-A8a	P2b-C8a	P3b-E8a	P4b-G8a	P5b-J8a	P6b-L8a	P7b-N8a	P8b-P8a
P1a-A8b	P2a-C8b	P3a-E8b	P4a-G8b	P5a-J8b	P6a-L8b	P7a-N8b	P8a-P8b

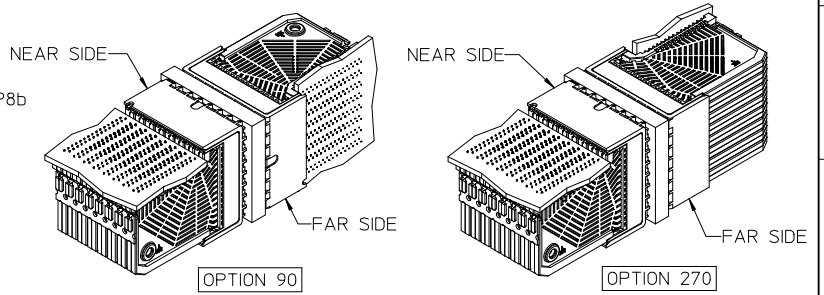

SEE SHEET 1 EC NO: UCP2013-4288 DRW: RWHIPPLE 2013/04/09 CHK: MWOLFE 2013/04/09 APPR: SMILLER 2013/08/26	QUALITY SYMBOLS 	GENERAL TOLERANCES (UNLESS SPECIFIED) <table border="1"> <tr><th>mm</th><th>INCH</th></tr> <tr><td>4 PLACES ± ---</td><td>± ---</td></tr> <tr><td>3 PLACES ± ---</td><td>± ---</td></tr> <tr><td>2 PLACES ± 0.13</td><td>± ---</td></tr> <tr><td>1 PLACE ± 0.25</td><td>± ---</td></tr> <tr><td>0 PLACE ±</td><td>±</td></tr> </table>	mm	INCH	4 PLACES ± ---	± ---	3 PLACES ± ---	± ---	2 PLACES ± 0.13	± ---	1 PLACE ± 0.25	± ---	0 PLACE ±	±	DIMENSION STYLE MM ONLY	SCALE 4:1	DESIGN UNITS METRIC	THIRD ANGLE PROJECTION
	mm	INCH																
	4 PLACES ± ---	± ---																
	3 PLACES ± ---	± ---																
2 PLACES ± 0.13	± ---																	
1 PLACE ± 0.25	± ---																	
0 PLACE ±	±																	
MATERIAL NO. SEE CHART	DOCUMENT NO. SD-76035-004	SHEET NO. 4 OF 4	I-TRAC 15 ROW BP GUIDE RIGHT ASSEMBLY SALES DRAWING 															
DRAFT WHERE APPLICABLE MUST REMAIN WITHIN DIMENSIONS							THIS DRAWING CONTAINS INFORMATION THAT IS PROPRIETARY TO MOLEX. INCORPORATED AND SHOULD NOT BE USED WITHOUT WRITTEN PERMISSION											

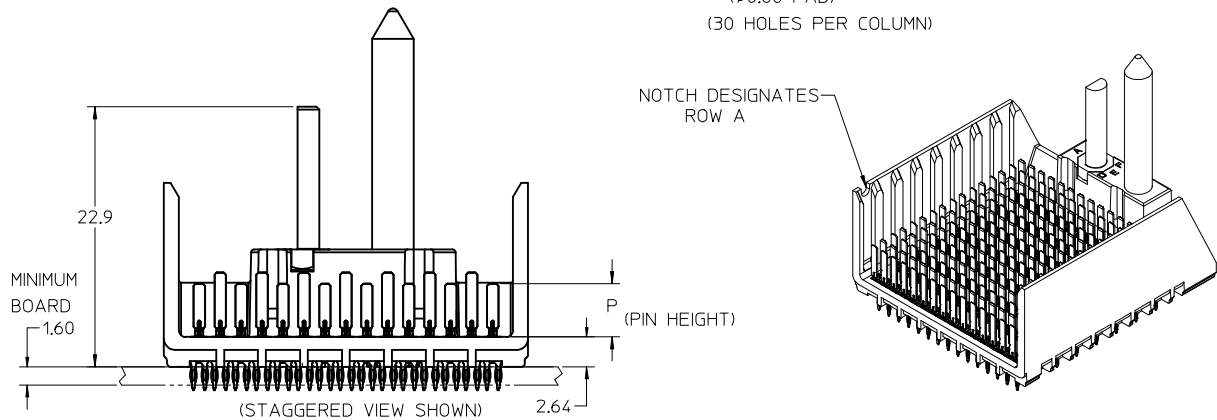
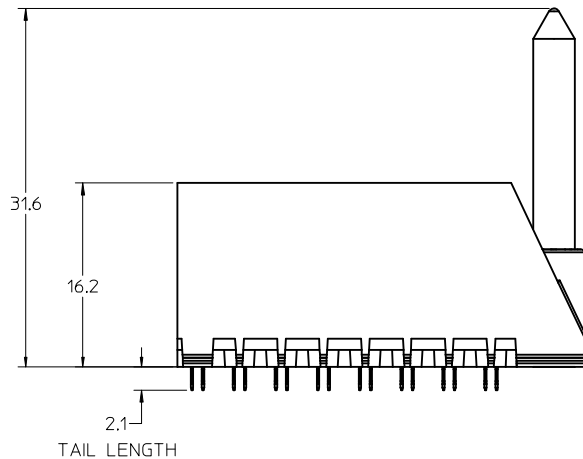
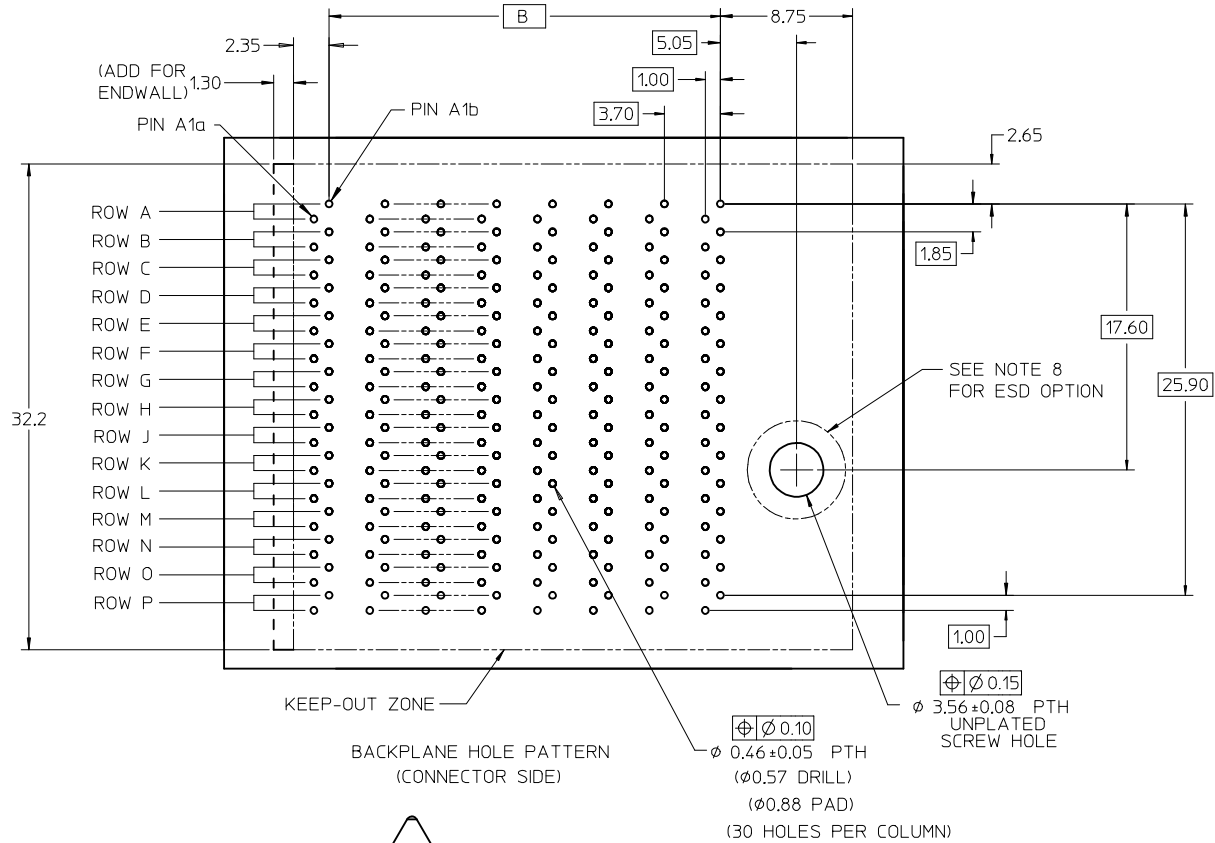
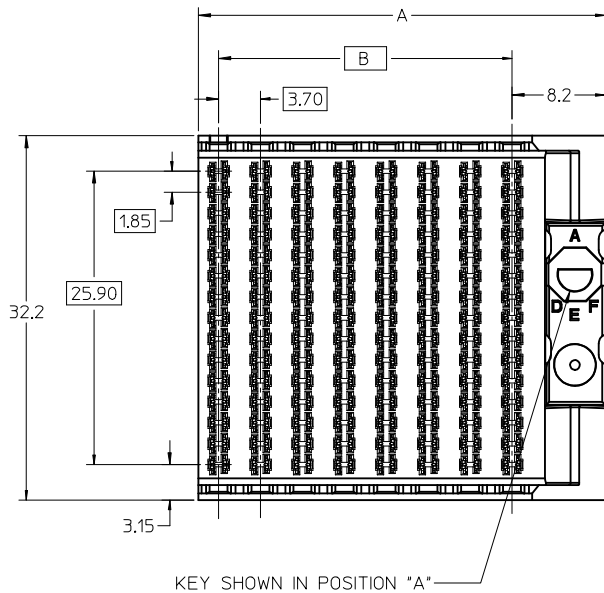

LEAD FREE CONVERSION EC NO: UCP2013-4288 DRW:RWHIPPLE 2013/04/09 CHK:MMOLFE 2013/04/09 APPR:SMILLER 2013/08/26	QUALITY SYMBOLS 	GENERAL TOLERANCES (UNLESS SPECIFIED)		DIMENSION STYLE MM ONLY	SCALE 3:1	DESIGN UNITS METRIC	THIRD ANGLE PROJECTION
		4 PLACES ± --- ± ---	DRAWN BY BPISZCZOR	DATE 2007/02/28	TITLE I-TRAC 15 ROW BP GUIDE RIGHT ASSEMBLY SALES DRAWING		
		3 PLACES ± --- ± ---	CHECKED BY JLAURX	DATE 2007/02/28	molex		
		2 PLACES ± 0.13 ± ---	APPROVED BY CBIXLER	DATE 2007/02/28	MATERIAL NO. SEE CHART	DOCUMENT NO. SD-76035-004	SHEET NO. 1 OF 4
1 PLACE ± 0.25 ± ---	ANGULAR ± 1/2°		THIS DRAWING CONTAINS INFORMATION THAT IS PROPRIETARY TO MOLEX INCORPORATED AND SHOULD NOT BE USED WITHOUT WRITTEN PERMISSION				
0 PLACE ± ±	DRAFT WHERE APPLICABLE MUST REMAIN WITHIN DIMENSIONS						

76035-****

MODULE TYPE -- TAIL PLATING TYPE
 GUIDE RIGHT -- MATTE TIN (FORMERLY TIN/LEAD) = 4
 GUIDE RIGHT -- MATTE TIN = 5
 GUIDE RIGHT W/END WALL -- MATTE TIN (FORMERLY TIN/LEAD) = 8
 GUIDE RIGHT W/END WALL -- MATTE TIN = 9

OF COLUMNS
 8 = 8 COL
 9 = 9 COL
 1 = 10 COL

KEY ORIENTATION
 0 = NO KEY
 1 = A
 2 = B
 3 = C
 4 = D
 5 = E
 6 = F
 7 = G
 8 = H

PIN LENGTH (P)
 2 = 3.90 - 30 GOLD
 3 = 4.70 - 30 GOLD
 4 = 5.70 - 30 GOLD
 5 = 4.70 & 5.70 - 30 GOLD STAGGERED
 6 = 3.90 - 10 GOLD
 7 = 4.70 - 10 GOLD
 8 = 5.70 - 10 GOLD
 9 = 4.70 & 5.70 - 10 GOLD STAGGERED

MATERIAL NUMBER	# OF COLUMNS	DIM "A"	DIM "B"
76035-48**	8	35.9	25.90
76035-49**	9	39.6	29.60
76035-41**	10	43.3	33.30
76035-51**	8	35.9	25.90
76035-59**	9	39.6	29.60
76035-51**	10	43.3	33.30

GUIDE RIGHT STYLE

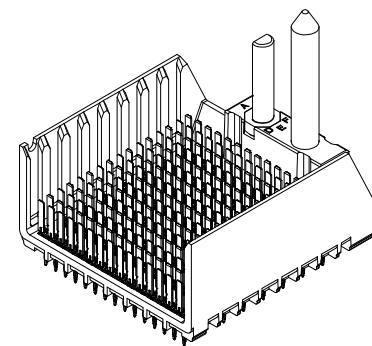

MATERIAL NUMBER	# OF COLUMNS	DIM "A"	DIM "B"
76035-88**	8	37.2	25.90
76035-89**	9	40.9	29.60
76035-81**	10	44.6	33.30
76035-98**	8	37.2	25.90
76035-99**	9	40.9	29.60
76035-91**	10	44.6	33.30

GUIDE RIGHT W/END WALL STYLE

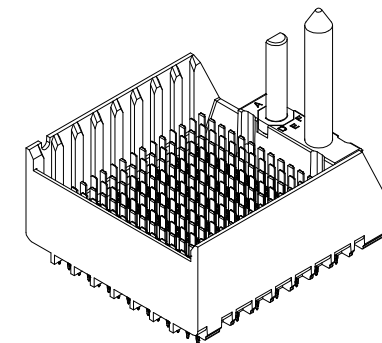

SEE SHEET 1 EC NO: UCP2013-4288 DRW: RMH/PPLE 2013/04/09 CHK: MWOLFE 2013/04/09 APPR: SMILLER 2013/08/26	QUALITY SYMBOLS	GENERAL TOLERANCES (UNLESS SPECIFIED)	DIMENSION STYLE	SCALE	DESIGN UNITS	THIRD ANGLE PROJECTION
	▽=0	mm INCH	MM ONLY	4:1	METRIC	
	▽=0	4 PLACES ± --- ± ---	DRAWN BY DATE	TITLE	I-TRAC 15 ROW BP GUIDE RIGHT ASSEMBLY SALES DRAWING	
	▽=0	3 PLACES ± --- ± ---	CHECKED BY DATE	molex DOCUMENT NO. SD-76035-004 SHEET NO. 2 OF 4		
	2 PLACES ± 0.13 ± ---	APPROVED BY DATE				
	1 PLACE ± 0.25 ± ---	CBI XLER 2007/02/28	THIS DRAWING CONTAINS INFORMATION THAT IS PROPRIETARY TO MOLEX INCORPORATED AND SHOULD NOT BE USED WITHOUT WRITTEN PERMISSION			
	0 PLACE ± ±					
	ANGULAR ±1/2°	DRAFT WHERE APPLICABLE MUST REMAIN WITHIN DIMENSIONS				

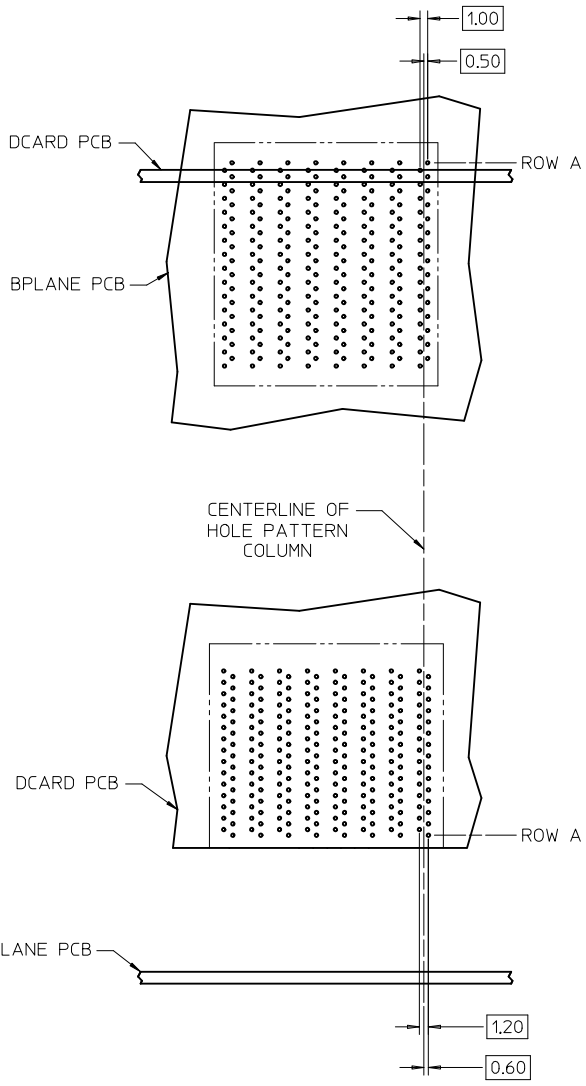

15 ROW I-TRAC BOARD RELATIONSHIPS

SCALE 2:1

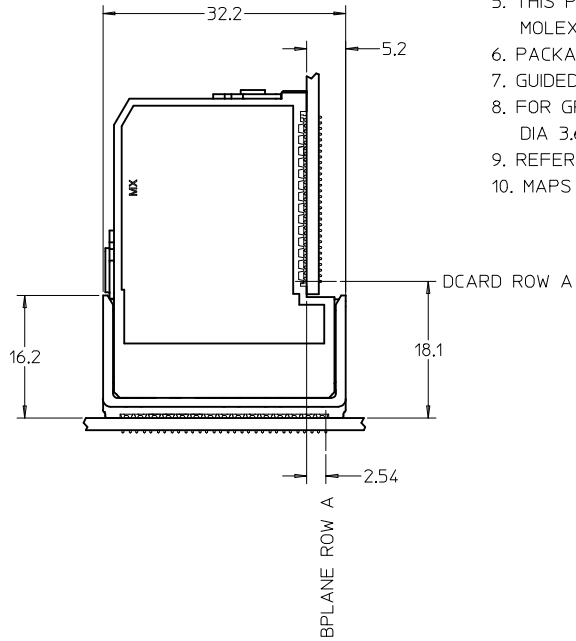

NOTES:

1. MATERIALS: HOUSING - LIQUID CRYSTAL POLYMER (LCP)
GLASS-FILLED, UL94V-0
TERMINALS - HIGH PERFORMANCE COPPER ALLOY
2. FINISH: 10 MICROINCH MIN.(MAPS) GOLD OR 30 MICROINCH MIN. GOLD
IN CONTACT AREA. SELECTIVE MATTE TIN ON PCB TAILS, NICKEL OVERALL.
3. REFER TO MOLEX PRODUCT SPECIFICATION PS-75710-999
FOR PERFORMANCE SPECIFICATIONS.
4. FOR MIXED CONTACT MATING LENGTHS, CONSULT MOLEX
FOR AVAILABILITY.
5. THIS PART CONFORMS TO CLASS B REQUIREMENTS OF
MOLEX COSMETIC SPEC PS-45499-002.
6. PACKAGE PER: PK-70873-586.
7. GUIDED PARTS TO BE SHIPPED WITH 2-56 UNC B SCREW P/N 73774-1000.
8. FOR GROUNDED GUIDE PINS USE DIA 3.56+/-0.08 (PTH),
DIA 3.66 (DRILL), AND DIA 6.5 (PAD).
9. REFER TO PCB ROUTING GUIDE FOR ANTIPAD AND ROUTING RECOMMENDATIONS.
10. MAPS (MOLEX ADVANCED PLATING SYSTEM).

SEE SHEET 1 EC NO: UCP2013-4288 DRW:RWHIPPLE 2013/04/09 CHKD:MMOLFE 2013/04/09 APPR:SMILLER 2013/08/26	QUALITY SYMBOLS ▽=0 ▽=0 ▽=0	GENERAL TOLERANCES (UNLESS SPECIFIED) <table border="1"> <tr> <th></th> <th>mm</th> <th>INCH</th> </tr> <tr> <td>4 PLACES</td> <td>± ---</td> <td>± ---</td> </tr> <tr> <td>3 PLACES</td> <td>± ---</td> <td>± ---</td> </tr> <tr> <td>2 PLACES</td> <td>± 0.13</td> <td>± ---</td> </tr> <tr> <td>1 PLACE</td> <td>± 0.25</td> <td>± ---</td> </tr> <tr> <td>0 PLACE</td> <td>±</td> <td>±</td> </tr> </table>		mm	INCH	4 PLACES	± ---	± ---	3 PLACES	± ---	± ---	2 PLACES	± 0.13	± ---	1 PLACE	± 0.25	± ---	0 PLACE	±	±	DIMENSION STYLE MM ONLY DRAWN BY DATE BPISZCZOR 2007/02/28 CHECKED BY DATE JLAURX 2007/02/28 APPROVED BY DATE CBIXLER 2007/02/28	SCALE 4:1 DESIGN UNITS METRIC THIRD ANGLE PROJECTION	TITLE I-TRAC 15 ROW BP GUIDE RIGHT ASSEMBLY SALES DRAWING molex DOCUMENT NO. SD-76035-004 SHEET NO. 3 OF 4
		mm	INCH																				
	4 PLACES	± ---	± ---																				
	3 PLACES	± ---	± ---																				
2 PLACES	± 0.13	± ---																					
1 PLACE	± 0.25	± ---																					
0 PLACE	±	±																					
DRAFT WHERE APPLICABLE MUST REMAIN WITHIN DIMENSIONS	ANGULAR ±1/2°	MATERIAL NO. SEE CHART																					
		SIZE C	THIS DRAWING CONTAINS INFORMATION THAT IS PROPRIETARY TO MOLEX INCORPORATED AND SHOULD NOT BE USED WITHOUT WRITTEN PERMISSION																				

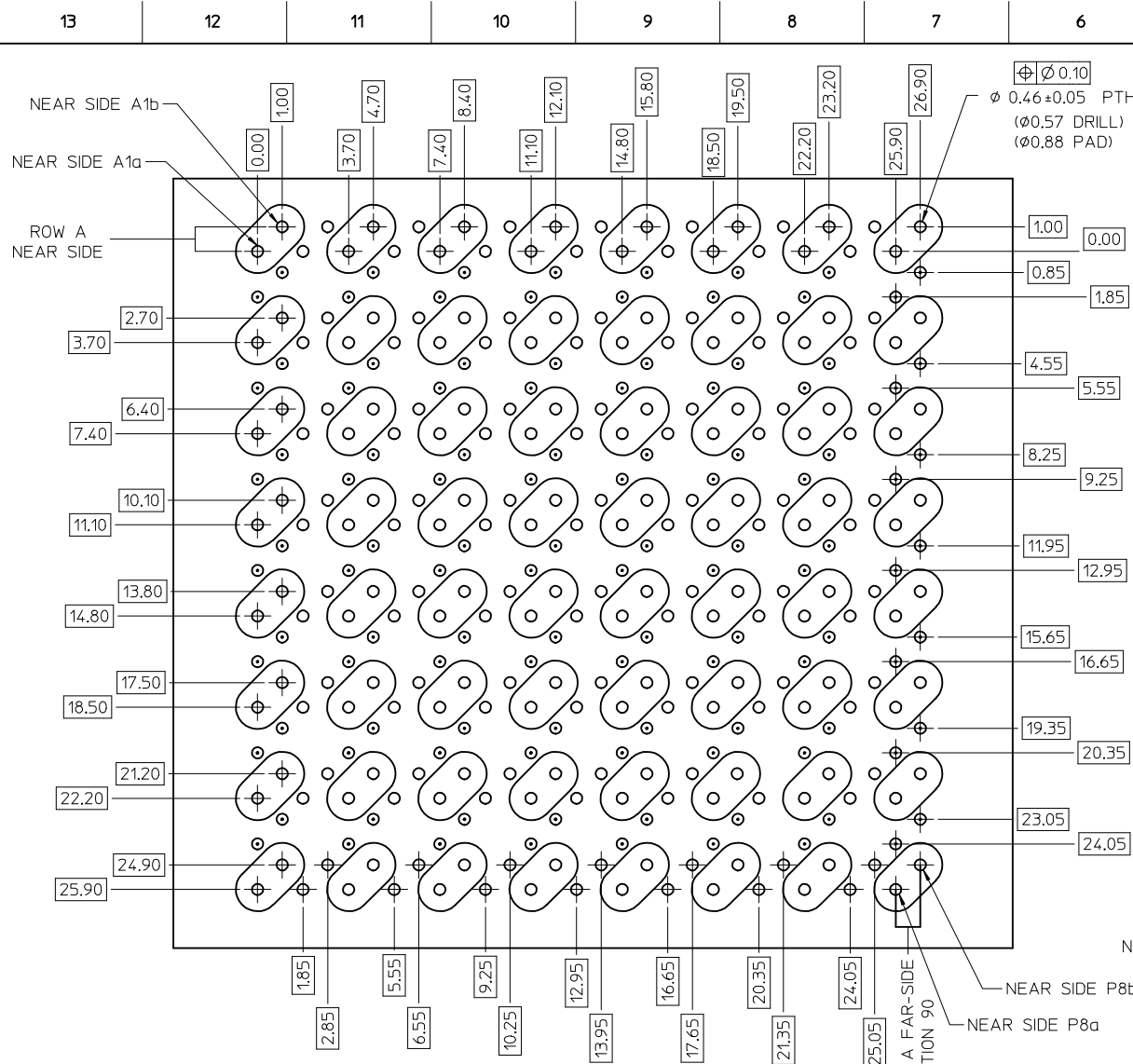

ORTHO PIN MAPPING

OPTION 90 (NEAR SIDE - FAR SIDE)

A1b-P8b	A2b-N8b	A3b-L8b	A4b-J8b	A5b-G8b	A6b-E8b	A7b-C8b	A8b-A8b
A1a-P8a	A2a-N8a	A3a-L8a	A4a-J8a	A5a-G8a	A6a-E8a	A7a-C8a	A8a-A8a
C1b-P7b	C2b-N7b	C3b-L7b	C4b-J7b	C5b-G7b	C6b-E7b	C7b-C7b	C8b-A7b
C1a-P7a	C2a-N7a	C3a-L7a	C4a-J7a	C5a-G7a	C6a-E7a	C7a-C7a	C8a-A7a
E1b-P6b	E2b-N6b	E3b-L6b	E4b-J6b	E5b-G6b	E6b-E6b	E7b-C6b	E8b-A6b
E1a-P6a	E2a-N6a	E3a-L6a	E4a-J6a	E5a-G6a	E6a-E6a	E7a-C6a	E8a-A6a
G1b-P5b	G2b-N5b	G3b-L5b	G4b-J5b	G5b-G5b	G6b-E5b	G7b-C5b	G8b-A5b
G1a-P5a	G2a-N5a	G3a-L5a	G4a-J5a	G5a-G5a	G6a-E5a	G7a-C5a	G8a-A5a
J1b-P4b	J2b-N4b	J3b-L4b	J4b-J4b	J5b-G4b	J6b-E4b	J7b-C4b	J8b-A4b
J1a-P4a	J2a-N4a	J3a-L4a	J4a-J4a	J5a-G4a	J6a-E4a	J7a-C4a	J8a-A4a
L1b-P3b	L2b-N3b	L3b-L3b	L4b-J3b	L5b-G3b	L6b-E3b	L7b-C3b	L8b-A3b
L1a-P3a	L2a-N3a	L3a-L3a	L4a-J3a	L5a-G3a	L6a-E3a	L7a-C3a	L8a-A3a
N1b-P2b	N2b-N2b	N3b-L2b	N4b-J2b	N5b-G2b	N6b-E2b	N7b-C2b	N8b-A2b
N1a-P2a	N2a-N2a	N3a-L2a	N4a-J2a	N5a-G2a	N6a-E2a	N7a-C2a	N8a-A2a
P1b-P1b	P2b-N1b	P3b-L1b	P4b-J1b	P5b-G1b	P6b-E1b	P7b-C1b	P8b-A1b
P1a-P1a	P2a-N1a	P3a-L1a	P4a-J1a	P5a-G1a	P6a-E1a	P7a-C1a	P8a-A1a

ORTHO PIN MAPPING

OPTION 270 (NEAR SIDE - FAR SIDE)

A1b-A1a	A2b-C1a	A3b-E1a	A4b-G1a	A5b-J1a	A6b-L1a	A7b-N1a	A8b-P1a
A1a-A1b	A2a-C1b	A3a-E1b	A4a-G1b	A5a-J1b	A6a-L1b	A7a-N1b	A8a-P1b
C1b-A2a	C2b-C2a	C3b-E2a	C4b-G2a	C5b-J2a	C6b-L2a	C7b-N2a	C8b-P2a
C1a-A2b	C2a-C2b	C3a-E2b	C4a-G2b	C5a-J2b	C6a-L2b	C7a-N2b	C8a-P2b
E1b-A3a	E2b-C3a	E3b-E3a	E4b-G3a	E5b-J3a	E6b-L3a	E7b-N3a	E8b-P3a
E1a-A3b	E2a-C3b	E3a-E3b	E4a-G3b	E5a-J3b	E6a-L3b	E7a-N3b	E8a-P3b
G1b-A4a	G2b-C4a	G3b-E4a	G4b-G4a	G5b-J4a	G6b-L4a	G7b-N4a	G8b-P4a
G1a-A4b	G2a-C4b	G3a-E4b	G4a-G4b	G5a-J4b	G6a-L4b	G7a-N4b	G8a-P4b
J1b-A5a	J2b-C5a	J3b-E5a	J4b-G5a	J5b-J5a	J6b-L5a	J7b-N5a	J8b-P5a
J1a-A5b	J2a-C5b	J3a-E5b	J4a-G5b	J5a-J5b	J6a-L5b	J7a-N5b	J8a-P5b
L1b-A6a	L2b-C6a	L3b-E6a	L4b-G6a	L5b-J6a	L6b-L6a	L7b-N6a	L8b-P6a
L1a-A6b	L2a-C6b	L3a-E6b	L4a-G6b	L5a-J6b	L6a-L6b	L7a-N6b	L8a-P6b
N1b-A7a	N2b-C7a	N3b-E7a	N4b-G7a	N5b-J7a	N6b-L7a	N7b-N7a	N8b-P7a
N1a-A7b	N2a-C7b	N3a-E7b	N4a-G7b	N5a-J7b	N6a-L7b	N7a-N7b	N8a-P7b
P1b-A8a	P2b-C8a	P3b-E8a	P4b-G8a	P5b-J8a	P6b-L8a	P7b-N8a	P8b-P8a
P1a-A8b	P2a-C8b	P3a-E8b	P4a-G8b	P5a-J8b	P6a-L8b	P7a-N8b	P8a-P8b

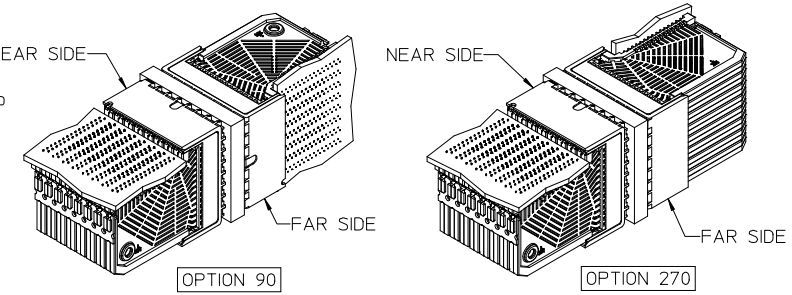

Orthogonal PCB Layout

- NOTES:
- SIGNAL PAIRS (SHARED VIAS)
 - NEAR SIDE GROUNDS
 - FAR SIDE GROUNDS

SEE SHEET 1 EC NO: UCP2013-4288 DRW: RWHIPPLE 2013/04/09 CHK: MWOLFE 2013/04/09 APPR: SMILLER 2013/08/26	QUALITY SYMBOLS 	GENERAL TOLERANCES (UNLESS SPECIFIED)		DIMENSION STYLE MM ONLY	SCALE 4:1	DESIGN UNITS METRIC	THIRD ANGLE PROJECTION		
		4 PLACES ± --- ± ---	3 PLACES ± --- ± ---	2 PLACES ± 0.13 ± ---	1 PLACE ± 0.25 ± ---	0 PLACE ± ±	DRAWN BY DATE BPISZCZOR 2007/02/28		
		ANGULAR ±1/2°					CHECKED BY DATE JLAURX 2007/02/28		
		DRAFT WHERE APPLICABLE MUST REMAIN WITHIN DIMENSIONS					APPROVED BY DATE CBIXLER 2007/02/28		
				MATERIAL NO. SEE CHART	DOCUMENT NO. SD-76035-004		SHEET NO. 4 OF 4		
THIS DRAWING CONTAINS INFORMATION THAT IS PROPRIETARY TO MOLEX. INCORPORATED AND SHOULD NOT BE USED WITHOUT WRITTEN PERMISSION									