

| REVISIONS | | | | | |
|-----------|-----|-----------------------|-----------|-----|------|
| P | LTR | DESCRIPTION | DATE | DWN | APVD |
| | L2 | REV PER ECN-22-150900 | 28APR2022 | RK | CSD |

| |
|--------------------------|
| AMP WIRE RANGE |
| 4/0 AWG STRANDED |

1. TONGUE MATERIAL THK 2.59 ± 0.08
[.102 ± .003]
- 2 MATERIAL: BODY - COPPER PER ASTM B-152
INSULATION - NYLON
MIL-M-20693, TYPE 1
- 3 FINISH: BODY - TIN PLATE PER ASTM B-545
INSULATION - COLOR BLUE
- 4 NOTE DELETED
- 5 FOR 19.43 [.765] MAX WIRE INS DIA
- 6 MAX OPERATING TEMP IS 105°C
- 7 CROSS SECTIONAL AREA RANGE IS
96.3-117mm² [190,000-231,000] CMA
FOR STRANDED WIRE.

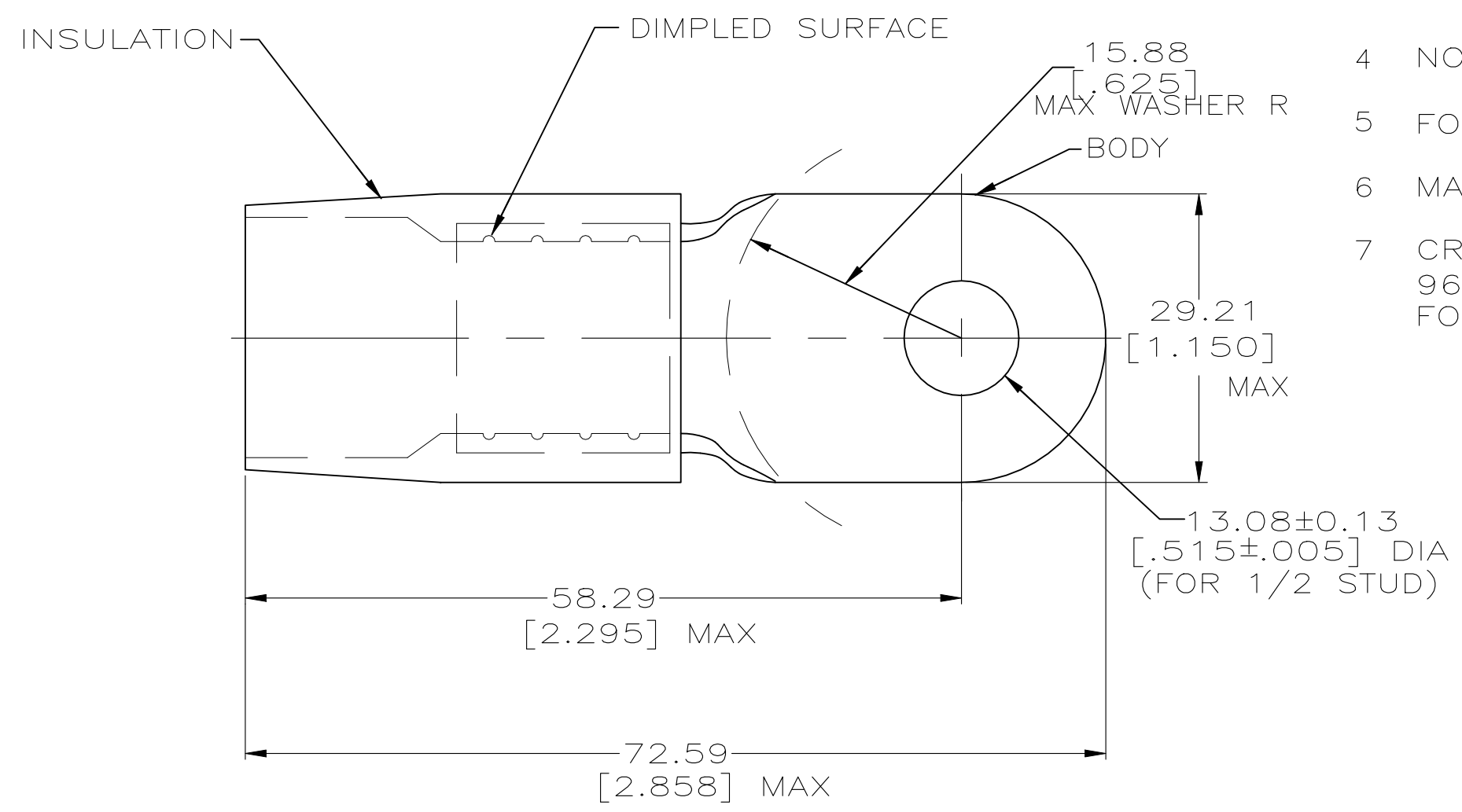

| | | |
|-----|--------------|-------------|
| - | LOOSE PC | 324188 |
| QTY | PACKAGE TYPE | PART NUMBER |

| | | | | | | | | | | | | | | | | |
|--|---------------|--------|------------|------------------|----------------------------|-------|-----------|---|---------------|-----|-------|---------------|-------|-----|-------|-----|
| THIS DRAWING IS A CONTROLLED DOCUMENT. | | DWN | SS GOULDEN | 6/93 | STE TE Connectivity | | | | | | | | | | | |
| DIMENSIONS: MM [INCHES] | | CHK | R HERSEY | 6/93 | | | | | | | | | | | | |
| TOLERANCES UNLESS OTHERWISE SPECIFIED: | | APVD | JL MECKLEY | 6/93 | | | | NAME TERMINAL, RING TONGUE, TERMINYL WIRE SIZE: 4/0 | | | | | | | | |
| <table border="0"> <tr><td>0 PLC</td><td>± -</td></tr> <tr><td>1 PLC</td><td>± -</td></tr> <tr><td>2 PLC</td><td>± 0.20 [.008]</td></tr> <tr><td>3 PLC</td><td>± -</td></tr> <tr><td>4 PLC</td><td>± -</td></tr> <tr><td>ANGLES</td><td>± -</td></tr> </table> | | 0 PLC | ± - | 1 PLC | | | | | | ± - | 2 PLC | ± 0.20 [.008] | 3 PLC | ± - | 4 PLC | ± - |
| 0 PLC | ± - | | | | | | | | | | | | | | | |
| 1 PLC | ± - | | | | | | | | | | | | | | | |
| 2 PLC | ± 0.20 [.008] | | | | | | | | | | | | | | | |
| 3 PLC | ± - | | | | | | | | | | | | | | | |
| 4 PLC | ± - | | | | | | | | | | | | | | | |
| ANGLES | ± - | | | | | | | | | | | | | | | |
| MATERIAL | 2 | FINISH | 3 | APPLICATION SPEC | - | SIZE | CAGE CODE | DRAWING NO | RESTRICTED TO | | | | | | | |
| | | | | WEIGHT | - | A3 | 00779 | C-324188 | - | | | | | | | |
| CUSTOMER DRAWING | | | | | | SCALE | NTS | SHEET | 1 OF 1 | REV | L2 | | | | | |