

N
NEX10 Adaptor
N Plug – NEX®10 Plug

53S189-S00N1

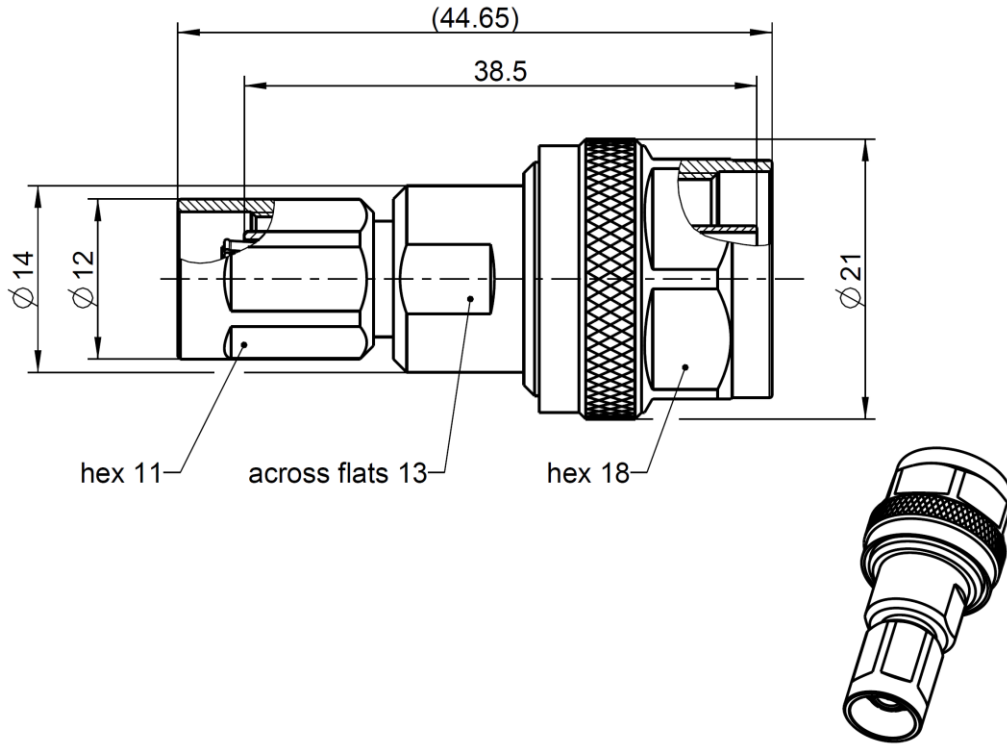

All dimensions are in mm; tolerances according to ISO 2768 m-H

Interface

According to NEX10 side: NEX10®
N side: IEC 61169-16, MIL-PRF-39012, CECC 22210

Material and Plating

Connector parts

Center contact
Outer contact
Outer contact
Body
Dielectric
Gasket

N side:
NEX10 side:

Material

Brass
Brass
Spring bronze
Brass
PTFE
Silicone

Plating

Silver, 3-6 µm
White bronze(e.g. Optalloy®)
Silver, 3-6 µm
White bronze(e.g. Optalloy®)

Dieses Dokument ist urheberrechtlich geschützt • This document is protected by copyright • Rosenberger Hochfrequenztechnik GmbH & Co. KG

RFB00035/12.20/6.4

N
NEX10 Adaptor
N Plug – NEX®10 Plug

53S189-S00N1

Electrical Data

Impedance 50 Ω
 Frequency DC to 11 GHz
 Return loss ≥ 36 dB @ DC to 4 GHz
 ≥ 28 dB @ 4 GHz to 6 GHz
 Insertion loss ≤ 0.05 x √f [GHz] dB
 Insulation resistance ≥ 5 GΩ
 Center contact resistance ≤ 2.0 mΩ, NEX10 side ≤ 1.0 mΩ, N side
 Outer contact resistance ≤ 1.0 mΩ, NEX10 side ≤ 0.25 mΩ, N side
 Operating voltage 500 V rms
 RF-leakage ≥ 110 dB @ DC to 6 GHz
 Power handling 100 W @ 2.0 GHz and 85°C ambient temperature
 Intermodulation (3rd order) ≥ 155 dBc (2 x 43 dBm) @ 0.4 – 6.0 GHz

Mechanical Data

	NEX10 side	N side
Mating cycles	≥ 100	≥ 500
Recommended torque	1.5 Nm	0.7 Nm to 1.1 Nm

Environmental Data

Temperature range -55 °C to +125 °C operating temperature
 Thermal shock IEC 61169-1 9.4.4
 Vibration IEC 61169-1 9.3.3 and IEC 60068-2-64
 Shock IEC 61169-1 9.3.14
 Degree of protection (mated pair) IEC 60529, IP68 24h / 1m
 RoHS compliant

Tooling

N/A

Suitable Cables

N/A

Weight

40 g/pc

While the information has been carefully compiled to the best of our knowledge, nothing is intended as representation or warranty on our part and no statement herein shall be construed as recommendation to infringe existing patents. In the effort to improve our products, we reserve the right to make changes judged to be necessary.

For the installation of the electrotechnical equipment, particular electrotechnical expertise is required.



Draft	Date	Approved	Date	Rev.	Engineering change number	Name	Date
F. Fraunhofer	21.04.2017	Chr. Janßen	01.02.2021	400	20-1927	B. Wollitzer	01.02.2021
Rosenberger Hochfrequenztechnik GmbH & Co. KG P.O.Box 1260 D-84526 Tittmoning Germany www.rosenberger.com						Tel. : +49 8684 18-0 Email : info@rosenberger.com	
						Page 2 / 2	