

THE REVISION STATUS OF ALL SHEETS OF THIS DRAWING IS THE SAME AS SHEET 1

LTR	DESCRIPTION	DATE	BY
-	Released	9/24/96	JP
A	Redrawn	6/27/01	JCL

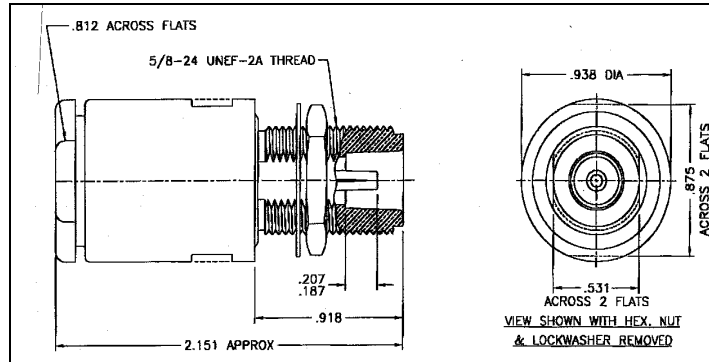

**I. MATERIALS & FINISHES**

- center contact: Gold Plated Beryllium Copper
- outer contact: Silver Plated Brass
- body: Silver Plated Brass
- crimp sleeve: Silver Plated Copper
- lockwasher: Spring Steel
- hex nut:: Silver Plated Brass
- dielectric: Teflon® PTFE
- gasket: Silicone Rubber
- shrink sleeve: Adhesive Lined Polyolefin
- attachment: braid clamp

**II. ELECTRICAL PROPERTIES**

- impedance: 50 ohms
- working voltage: 1000 vrms (max)
- vswr: 1.25:1 (max) up to 2.5 GHz
- insertion loss:  $0.10 \times \sqrt{F}$ ghz

Unless otherwise specified, dimensions are in inches. Tolerances are applicable when specified.

These drawings and specifications contain proprietary information which is the property of Times Microwave Systems.

Approvals		
Drawn	JP	9/24/96

**TIMES MICROWAVE SYSTEMS**  
 Wallingford, CT 06492  
 (203) 949-8400; (203) 949-8423.Fax  
 www.timesmicrowave.com

**TC-600-NFC-BH**  
 Type-N female (jack) Bulkhead  
 for LMR-600 Cable

Size A	CAGE CODE <b>68999</b>	Drawing No.: <b>3190-466</b>
-----------	---------------------------	---------------------------------

Scale: NA	Rev. (A)	Sheet: 1 of 1
-----------	----------	---------------