



ON Semiconductor®

# QSB34GR / QSB34ZR / QSB34CGR / QSB34CZR

## Surface-Mount Silicon Pin Photodiode

### Features

- Daylight Filter (QSB34GR and QSB34ZR Only)
- Surface-Mount Packages:
  - QSB34GR / QSB34CGR for Over-Mount Board
  - QSB34ZR / QSB34CZR for Under-Mount Board
- Fast PIN Photodiode
- Wide Reception Angle: 120°
- Large Chip Size: 3 mm x 3 mm
- Sensitive Area: 2.55 mm x 2.55 mm
- High Sensitivity
- Low Capacitance
- Available in 0.470 inch (12 mm) Width Tape on 7 inch (178 mm) Diameter Reel: 1,000 Units per Reel

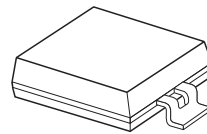

### Schematic

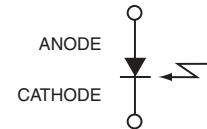

### Ordering Information

Part Number	Operating Temperature	Package	Packing Method
QSB34GR	-25 to +85°C	PLCC 2L	Tape and Reel
QSB34ZR			
QSB34CGR			
QSB34CZR			

QSB34GR / QSB34ZR / QSB34CGR / QSB34CZR — Surface-Mount Silicon Pin Photodiode

### Absolute Maximum Ratings

Stresses exceeding the absolute maximum ratings may damage the device. The device may not function or be operable above the recommended operating conditions and stressing the parts to these levels is not recommended. In addition, extended exposure to stresses above the recommended operating conditions may affect device reliability. The absolute maximum ratings are stress ratings only. Values are at  $T_A = 25^\circ\text{C}$  unless otherwise specified.

Symbol	Parameter	Min.	Unit
$T_{\text{OPR}}$	Operating Temperature	-25 to +85	°C
$T_{\text{STG}}$	Storage Temperature	-40 to + 85	
$T_{\text{SOL}}^{(1)}$	Soldering Temperature	260	
$V_R$	Reverse Voltage	32	V
$P_C$	Power Dissipation at (or below) $25^\circ\text{C}$ Free Air Temperature	150	mW

**Note:**

1. Soldering time  $\leq 5$  s.

### Recommend $I_R$ Reflow Soldering Profile

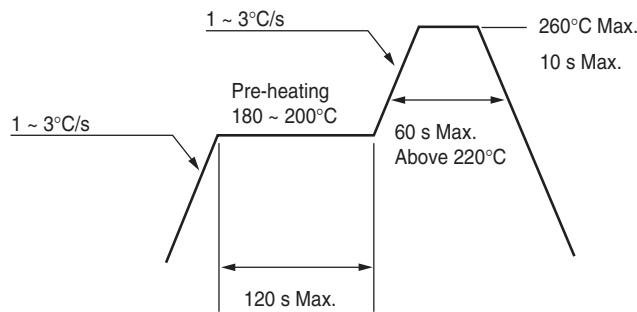

## Electrical / Optical Characteristics

Values are at  $T_A = 25^\circ\text{C}$  unless specified otherwise.

Symbol	Parameter	Test Conditions	Min.	Typ.	Max.	Units
$V_R$	Reverse Voltage	$I_R = 0.1 \text{ mA}$	32			V
$I_{R(D)}$	Dark Reverse Current	$V_R = 10 \text{ V}$			30	nA
$\lambda_{PK}$	Peak Sensitivity			940		nm
$\theta$	Reception Angle at 1/2 Power			$\pm 60$		$^\circ$
$I_{PH}$	Photo Current	$E_e = 1 \text{ mW / cm}^2$ , $V_{CE} = 5 \text{ V}$	25	37		$\mu\text{A}$
C	Capacitance	$V_R = 3 \text{ V}$		25		pF
$t_r$	Rise Time	$V_R = 10 \text{ V}, R_L = 50 \Omega$		50		ns
$t_f$	Fall Time			50		ns
$\lambda_{0.5}$	Special Sensitivity	QSB34GR, QSB34ZR	730		1100	nm
		QSB34CGR, QSB34CZR	400		1100	

### Typical Performance Characteristics

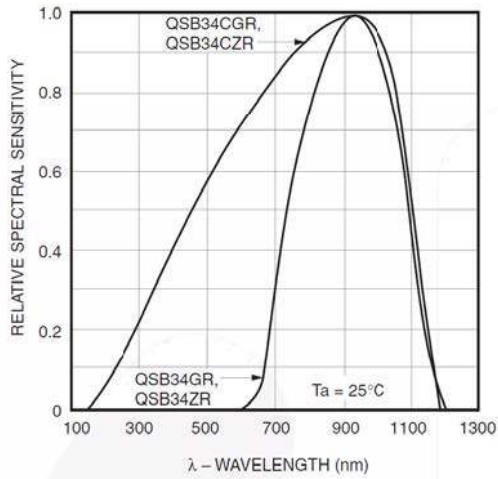

Figure 1. Relative Spectral Sensitivity vs. Wavelength

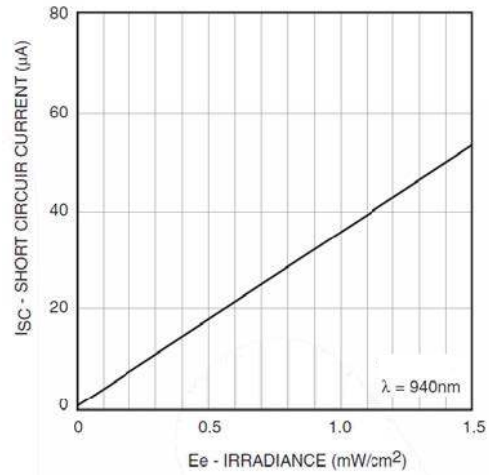

Figure 2. Short Circuit Current vs. Irradiance

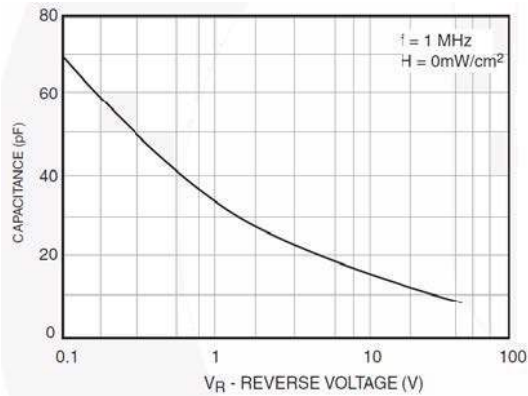

Figure 3. Capacitance vs. Reverse Voltage

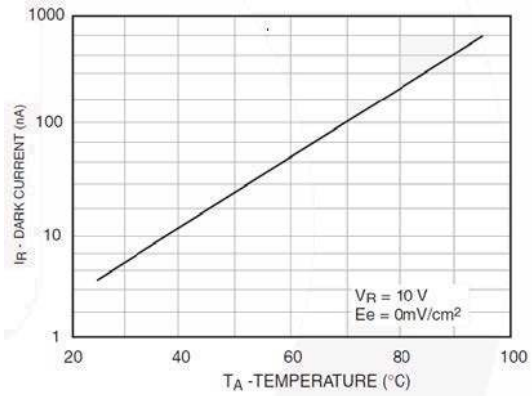

Figure 4. Dark Current vs. Temperature

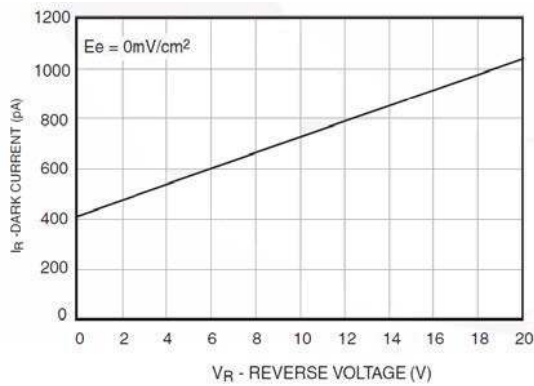

Figure 5. Dark Current vs. Reverse Voltage

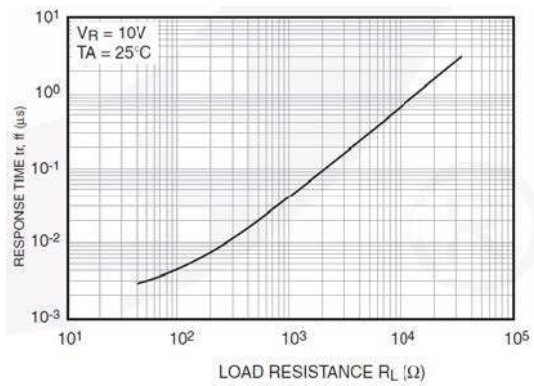
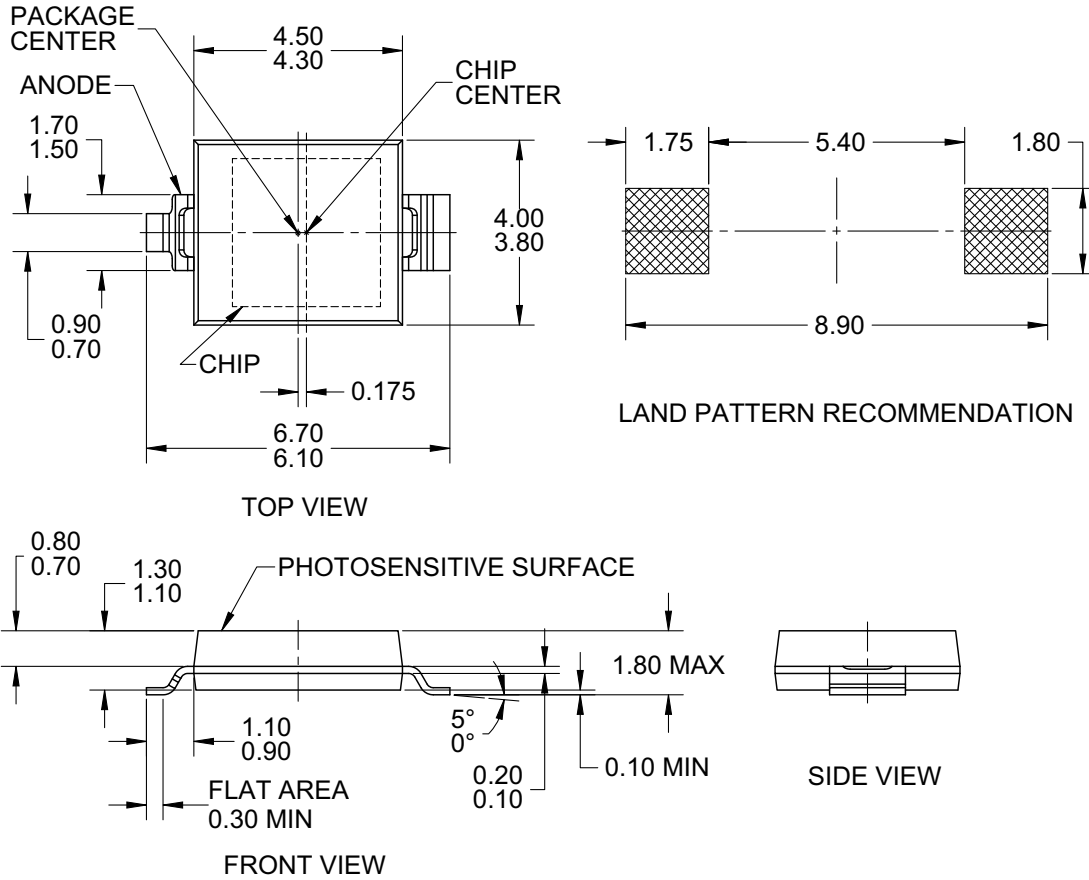

Figure 6. Response Time vs. Load Resistance

**Physical Dimensions**

**PLCC 2L (QSB34GR / CGR)**



- NOTES:
- A. NO INDUSTRY STANDARD APPLIES TO THIS PACKAGE
  - B. ALL DIMENSIONS ARE IN MILLIMETERS
  - C. DIMENSIONS DO NOT INCLUDE MOLD FLASH OR BURRS
  - D. DRAWING FILENAME: MKT-DCD02Arev1

**Figure 7. PLCC DETECTOR (ACTIVE)**

Package drawings are provided as a service to customers considering ON Semiconductor components. Drawings may change in any manner without notice. Please note the revision and/or date on the drawing and contact a ON Semiconductor representative to verify or obtain the most recent revision. Package specifications do not expand the terms of ON Semiconductor's worldwide terms and conditions, specifically the warranty therein, which covers ON Semiconductor products.



# Tape and Reel Dimensions

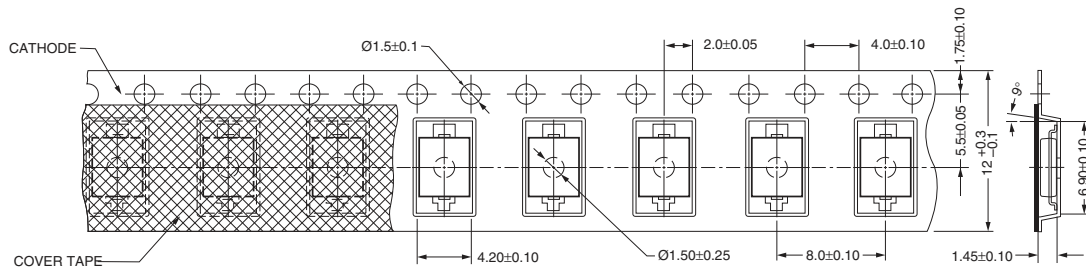
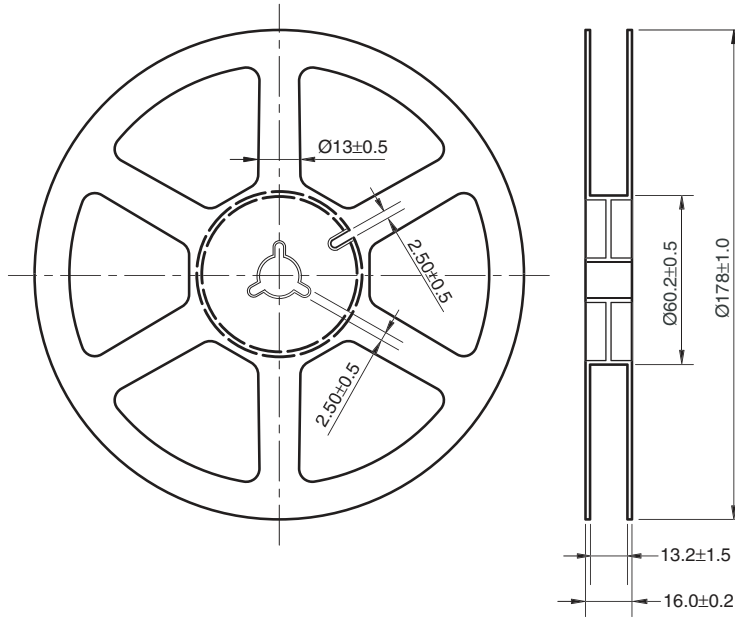

Unit: mm

ON Semiconductor and  are trademarks of Semiconductor Components Industries, LLC dba ON Semiconductor or its subsidiaries in the United States and/or other countries. ON Semiconductor owns the rights to a number of patents, trademarks, copyrights, trade secrets, and other intellectual property. A listing of ON Semiconductor's product/patent coverage may be accessed at [www.onsemi.com/site/pdf/Patent-Marking.pdf](http://www.onsemi.com/site/pdf/Patent-Marking.pdf). ON Semiconductor reserves the right to make changes without further notice to any products herein. ON Semiconductor makes no warranty, representation or guarantee regarding the suitability of its products for any particular purpose, nor does ON Semiconductor assume any liability arising out of the application or use of any product or circuit, and specifically disclaims any and all liability, including without limitation special, consequential or incidental damages. Buyer is responsible for its products and applications using ON Semiconductor products, including compliance with all laws, regulations and safety requirements or standards, regardless of any support or applications information provided by ON Semiconductor. "Typical" parameters which may be provided in ON Semiconductor data sheets and/or specifications can and do vary in different applications and actual performance may vary over time. All operating parameters, including "Typicals" must be validated for each customer application by customer's technical experts. ON Semiconductor does not convey any license under its patent rights nor the rights of others. ON Semiconductor products are not designed, intended, or authorized for use as a critical component in life support systems or any FDA Class 3 medical devices or medical devices with a same or similar classification in a foreign jurisdiction or any devices intended for implantation in the human body. Should Buyer purchase or use ON Semiconductor products for any such unintended or unauthorized application, Buyer shall indemnify and hold ON Semiconductor and its officers, employees, subsidiaries, affiliates, and distributors harmless against all claims, costs, damages, and expenses, and reasonable attorney fees arising out of, directly or indirectly, any claim of personal injury or death associated with such unintended or unauthorized use, even if such claim alleges that ON Semiconductor was negligent regarding the design or manufacture of the part. ON Semiconductor is an Equal Opportunity/Affirmative Action Employer. This literature is subject to all applicable copyright laws and is not for resale in any manner.

## PUBLICATION ORDERING INFORMATION

### LITERATURE FULFILLMENT:

Literature Distribution Center for ON Semiconductor  
19521 E. 32nd Pkwy, Aurora, Colorado 80011 USA  
**Phone:** 303-675-2175 or 800-344-3860 Toll Free USA/Canada  
**Fax:** 303-675-2176 or 800-344-3867 Toll Free USA/Canada  
**Email:** [orderlit@onsemi.com](mailto:orderlit@onsemi.com)

**N. American Technical Support:** 800-282-9855 Toll Free  
USA/Canada  
**Europe, Middle East and Africa Technical Support:**  
Phone: 421 33 790 2910  
**Japan Customer Focus Center**  
Phone: 81-3-5817-1050

**ON Semiconductor Website:** [www.onsemi.com](http://www.onsemi.com)  
**Order Literature:** <http://www.onsemi.com/orderlit>  
For additional information, please contact your local  
Sales Representative