

REVISION(S)			
LTR	DESCRIPTION	INIT	APP'D
O	ECN: 0S60-0121-04	E.T 05/05/04	B.P 5/7/04
A	ECN: 0S60-0271-04	E.T 11/3/04	B.P 11/9/04
B	ECR-06-017841	E.T 7/25/06	V.K 7/25/06

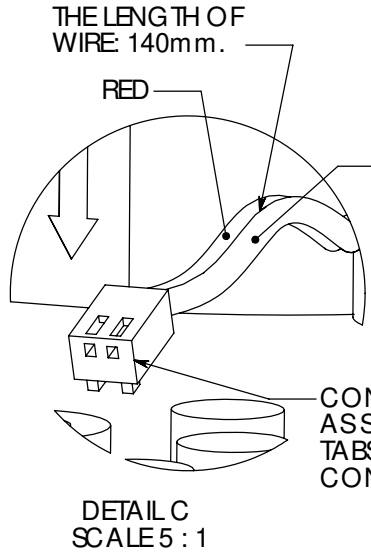

CONFIRM WIRE CONFIGURATION AS SHOWN WITH CONNECTOR TABS FACE DOWN
CONNECTOR: MOLEX 22-01-3027 2695 - 2 PIN.

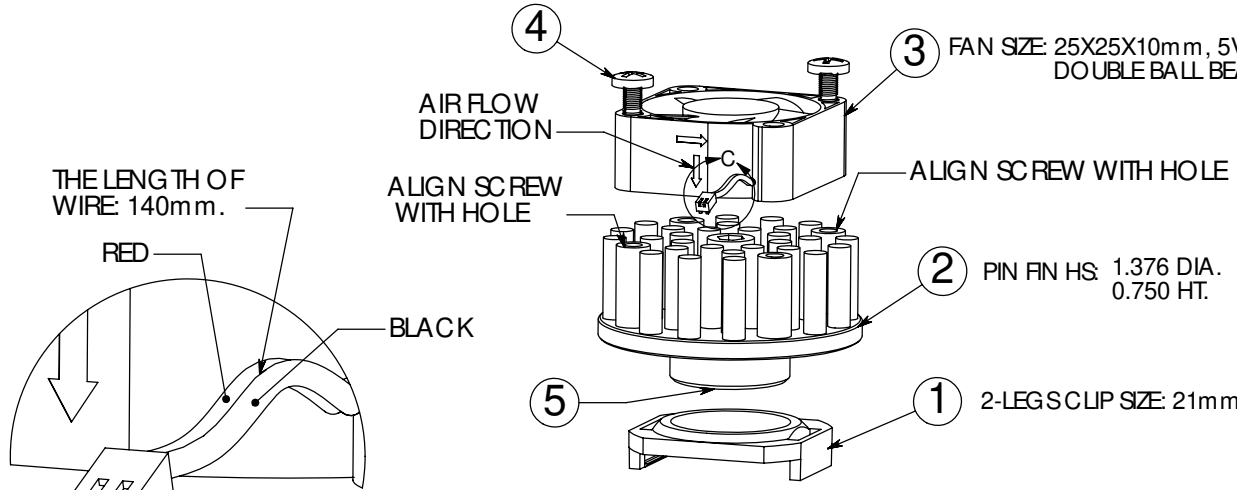
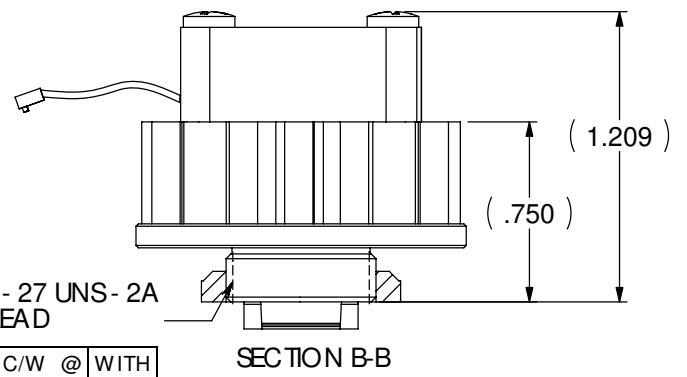
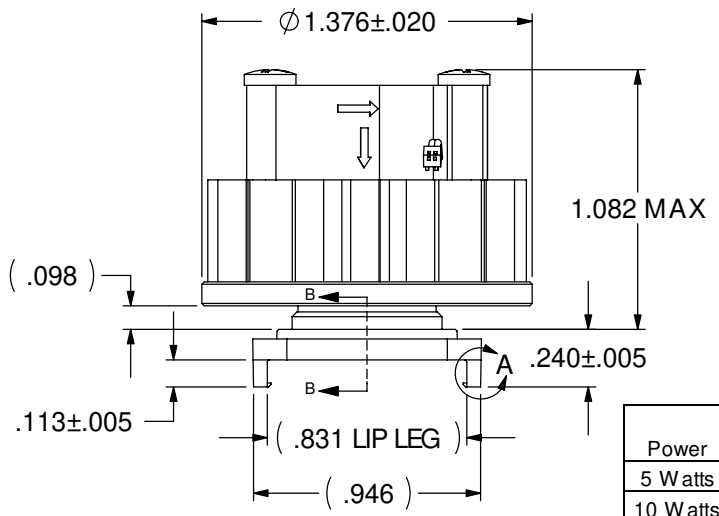
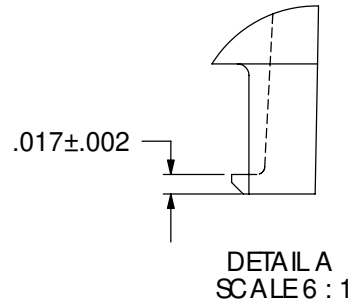

- MATERIAL:
HEAT SINK: ALUM. (BLACK ANODIZE)
CLIP: BLACK PEI (UL94-VO)
- BEFORE THE HEATSINK APPLICATION, THE USER SHOULD IDENTIFY THE SPECIFICATION OF MAXIMUM LOAD ON THE BGA PACKAGE.

HEATSINK TORQUE SPECIFICATIONS CONVERTED TO FORCE.
BARE DIE PACKAGE:
1.5 POUND-FORCE INCH TORQUE = 8.5 POUND-FORCE (0.17 NEWTON TORQUE = 37.81 NEWTON)

2.0 POUND-FORCE INCH TORQUE = 11.4 POUND-FORCE (0.23 NEWTON METER TORQUE = 50.71NEWTON)

FULL SIZE LID PACKAGE:
1.5 POUND-FORCE INCH TORQUE = 8.3 POUND-FORCE (0.17 NEWTON TORQUE = 36.92NEWTON)

2.0 POUND-FORCE INCH TORQUE = 11.1 POUND-FORCE (0.23 NEWTON METER TORQUE = 49.38NEWTON)
- REMOVE CLIP WITH REMOVAL TOOL P/N: 1542616-1.
- RoHS COMPLIANT AND CERTIFIED.

Power	° C/W @ Ambient	° C/W @ 200 LFM	° C/W @ 400 LFM	° C/W @ 600 LFM	WITH FAN
5 Watts	11.21	5.54	3.60	3.05	4.18
10 Watts	9.66	5.41	3.51	2.94	4.02
15 Watts	8.82	5.21	3.31	2.88	3.88

CUSTOMER DRAWING
SPECIFICATIONS ARE SUBJECT TO CHANGE WITHOUT NOTICE

ITEM	DESCRIPTION	QTY
1	MOUNTING CLIP	1
2	HEAT SINK	1
3	FAN	1
4	SCREWS	2
5	INTERFACE	1

tyco / Electronics Attleboro Falls Massachusetts 02763

UNLESS OTHERWISE SPECIFIED TO LEF RANGES ARE:
.XX ±
.XXX ±
.XXXX ±
ANGLES ±*

DO NOT SCALE

DRAWN BY: ETAO DATE: 05/05/04 MATERIAL: SEE NOTE

ENGINEER: B.PETROCELLI DATE: 5/7/04 FINISH: SEE NOTE

FILENAME: PROJECT: SYSTEM:

CONFIDENTIAL PROPERTY OF TYCO ELECTRONICS NOT TO BE DISCLOSED TO OTHERS REPRODUCED OR USED FOR ANY PURPOSES EXCEPT AS AUTHORIZED IN WRITING BY AN AUTHORIZED OFFICIAL OF TYCO. MUST BE RETURNED TO TYCO ON DEMAND, ON COMPLETION OF ORDERS OR OTHER PURPOSES FOR WHICH LENT.

TITLE: 21mm PIN FIN HEAT SINK ASSEMBLY (HTS276B-U)

DIMENSIONS ARE IN: INCHES SCALE: 1.25:1 PART NO.: 1542005-3 SHEET: 1 OF 1

TYPED ANGLE PROJECTION: SIZE: A DWG. NO.: C-1542005-3 REV: B