



8 dBi Omni Antenna 3,300-3,800 MHz N Type Female Connector

Antennas Technical Data Sheet

PE51OM1047

Features

- All weather operation
- $\pm 45^\circ$ Slant
- 2x2 MIMO
- PVC radome
- Integral N-Female connectors
- Commercial grade design
- 360° Omnidirectional Pattern

Applications

- Point to Multipoint and Non Line of Sight (NLOS) Applications
- 8 dBi gain
- 3500, LTE, and CBRS Cellular Band Operation

Description

The PE51OM1047 from Pasternack is a high performance 5G / LTE outdoor omnidirectional antenna designed for Cellular Networks. The PE51OM1047 operates from 3300 to 3800 MHz which is ideal for 5G, LTE, and MIMO 2x2 applications in CBRS band. The Multi-Band design of the Pasternack PE51OM1047 antenna eliminates the need to purchase different antennas for each frequency. The same antenna can be used for a wide array of base station cellular applications where wide coverage is desired. Pasternack's PE51OM1047 can be used to distribute Cellular telecommunication signals over a large area.

The omnidirectional antenna with Dual Slant ($\pm 45^\circ$) polarization PE51OM1047 from Pasternack has Type N connectors and 8 dBi of gain. The Type N connectorized PE51OM1047 antenna from Pasternack excels in large open areas. The mounting bracket and hardware are included for easy installation. Our Pasternack ISO 9001:2008 registered facilities in Irvine, CA ships all Type N RF, microwave and millimeter wave waveguide components from stock the same day you purchase them. Pasternack offers the broadest and deepest in-stock inventory and is where to buy 5G antennas. Our expert technical support and friendly, knowledgeable customer service personnel are available to assist you with your particular needs for 5G / LTE outdoor omnidirectional 5G cellular antennas.

Configuration

Design	Omni
Band Type	Single
Radiation Pattern	Omni Directional
Polarization	$\pm 45^\circ$ Deg. Slant
Connector Type	N Female
Number of Ports	2
Lightning Protection	DC Ground

Electrical Specifications

Description	Minimum	Typical	Maximum	Units
Frequency Range	3,300		3,800	MHz
Input VSWR		2:1		
Impedance		50		Ohms
Gain		8		dBi
Gain Variation		± 1		dBi
Isolation		30		dB
Horizontal (Azimuth) Beam Width		Omnidirectional		
Vertical (Elevation) Beam Width		7		Degrees

Click the following link (or enter part number in "SEARCH" on website) to obtain additional part information including price, inventory and certifications: [8 dBi Omni Antenna 3,300-3,800 MHz N Type Female Connector PE51OM1047](#)



8 dBi Omni Antenna 3,300-3,800 MHz N Type Female Connector

Antennas Technical Data Sheet

PE51OM1047

Input Power 100 Watts

Mechanical Specifications

Radome Material	PVC
Radiator Material	Aluminum
Size	
Overall Length	21.7 in [551.18 mm]
Width	3 in [76.2 mm]
Height	3 in [76.2 mm]
Mounting Mast Diameter	1.18 to 2.16 in [29.97 to 54.86 mm]
Weight	2.2 lbs [997.9 g]

Environmental Specifications

Temperature	
Operating Range	-40 to +60 deg C
Wind Loading	124.274 MPH [200 KPH]

Compliance Certifications (see [product page](#) for current document)

Plotted and Other Data

Notes:

8 dBi Omni Antenna 3,300-3,800 MHz N Type Female Connector from Pasternack Enterprises has same day shipment for domestic and International orders. Our RF, microwave and millimeter wave products maintain a 99.4% availability and are part of the broadest selection in the industry.

Click the following link (or enter part number in "SEARCH" on website) to obtain additional part information including price, inventory and certifications: [8 dBi Omni Antenna 3,300-3,800 MHz N Type Female Connector PE51OM1047](#)

URL: <https://www.pasternack.com/single-antenna-3.3-3.8-ghz-8-dbi-gain-n-pe51om1047-p.aspx>

The information contained in this document is accurate to the best of our knowledge and representative of the part described herein. It may be necessary to make modifications to the part and/or the documentation of the part, in order to implement improvements. Pasternack reserves the right to make such changes as required. Unless otherwise stated, all specifications are nominal. Pasternack does not make any representation or warranty regarding the suitability of the part described herein for any particular purpose, and Pasternack does not assume any liability arising out of the use of any part or documentation.

PE51OM1047 CAD Drawing

8 dBi Omni Antenna 3,300-3,800 MHz N Type Female Connector

REVISIONS		
REV.	DESCRIPTION	DATE
A	INITIAL RELEASE	05/04/2021
		APPROVED
		KHIETPAS

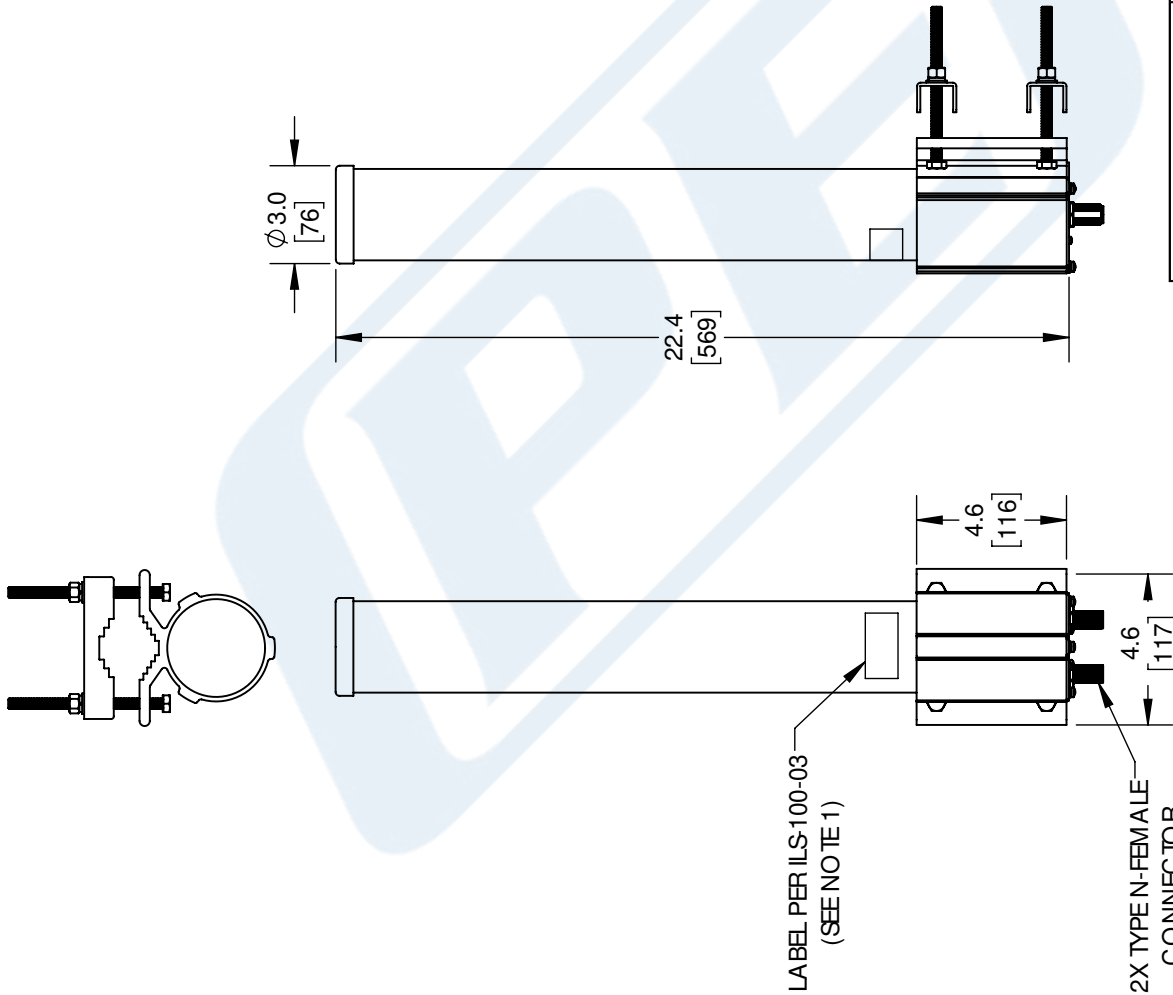

NOTES:

1. LABEL PER ILS-100-03 (FOR INTERNAL REFERENCE ONLY)
LABEL LOCATION FOR REFERENCE ONLY

THESE COMMODITIES, TECHNOLOGY OR SOFTWARE WERE EXPORTED FROM THE UNITED STATES IN ACCORDANCE WITH THE EXPORT ADMINISTRATION REGULATIONS. DIVERSION CONTRARY TO U.S. LAW PROHIBITED.

UNLESS OTHERWISE SPECIFIED LEADING DIMENSIONS ARE INCHES DIMENSIONS IN [] ARE MILLIMETERS

TOLERANCES:
 .X = ±.2 [5.08] FRACTIONS ± 1/32
 .XX = ±.02 [.51] ANGLES ± 1°
 .XXX = ±.005 [.13]

CABLE LENGTH (L), TOLERANCES:
 L ≤ 12 [305] = +1 [25] / -0
 12 [305] < L ≤ 60 [1524] = +2 [51] / -0
 60 [1524] < L ≤ 120 [3048] = +4 [102] / -0
 120 [3048] < L ≤ 300 [7620] = +6 [152] / -0
 300 [7620] < L = +5%L / -0

ALL DIMENSIONS SHOWN ARE FOR REFERENCE ONLY.

PE PASTERNAK
an INFINITI® brand

Pasternack Enterprises, Inc.
P. O. Box 16759, Irvine, CA 92623.
Phone: 1.949.261.1920 | 1.866.727.8376
Fax: 1.949.261.7451
Website: www.pasternack.com
E-mail: sales@pasternack.com

SIZE A CAGE CODE 53919 DRAWN BY BPUCHASKI ITEM NO. PE51OM1047
 SHEET 1 OF 1 SCALE N/A REV A

THIRD-ANGLE PROJECTION

THE INFORMATION AND DESIGN IN THIS DOCUMENT IS THE PROPERTY OF PASTERNAK CORPORATION ALL RIGHTS RESERVED.