

- PART NUMBER 2098541-5 SHOWN ON DRAWING.
- TPA AND CPA (WHEN APPLICABLE) ARE SHIPPED IN THEIR PRE-LATCHED POSITIONS. SEE INSTRUCTION SHEET 408-8928 FOR DIRECTIONS ON MOVING THE CPA AND TPA TO THE PRE-LATCHED POSITION, IF NECESSARY.
- TERMINALS SOLD SEPARATELY. FOR USE WITH TE MCP 1.2mm CLEAN BODY CONTACT WITH WIRE SEAL. SEE AMP MCP 1.2-CB (CLEAN BODY) TABLE FOR APPLICABLE PART NUMBERS.
- APPLICABLE HEADER INTERFACE DRAWING 114-18679-3 IS AVAILABLE UPON REQUEST. A COPY OF THIS DRAWING CAN BE OBTAINED FROM THE TYCO ELECTRONICS PRODUCT MANAGER, VIA YOUR TYCO ELECTRONICS SALES REPRESENTATIVE OR CUSTOMER SERVICE.
- MINIMUM FEED THROUGH CONDITION WITH 0.5mm CLEARANCE ALL AROUND.
- A "X" IN THIS TABLE INDICATES THAT THE TERMINAL CAVITY IS BLOCKED AND WILL NOT ALLOW INSERTION OF THE MATING TERMINAL. A "O" IN THIS TABLE INDICATES THAT THE TERMINAL CAVITY IS OPEN AND WILL ALLOW INSERTION OF THE MATING TERMINAL.
- TRACEABILITY PRINTED IN THIS LOCATION AT ASSEMBLY.
- ICD IS DEPENDENT UPON WIRE INSULATION TYPE AND OD. MUST BE SUFFICIENT TO GRIP SEAL SO IT DOES NOT SLIDE OUT OF INSULATION CRIMP WHEN INSERTING INTO CONNECTOR CAVITY BUT NOT TEAR THE SEAL.
- REFERENCE ISOMETRIC VIEWS ON SEET 2.
- CONNECTOR MEETS USCAR2 REV 4 WITH THE FOLLOWING EXCEPTIONS: TPA DISENGAGE FORCE 2ND REMOVAL = 8N MIN.

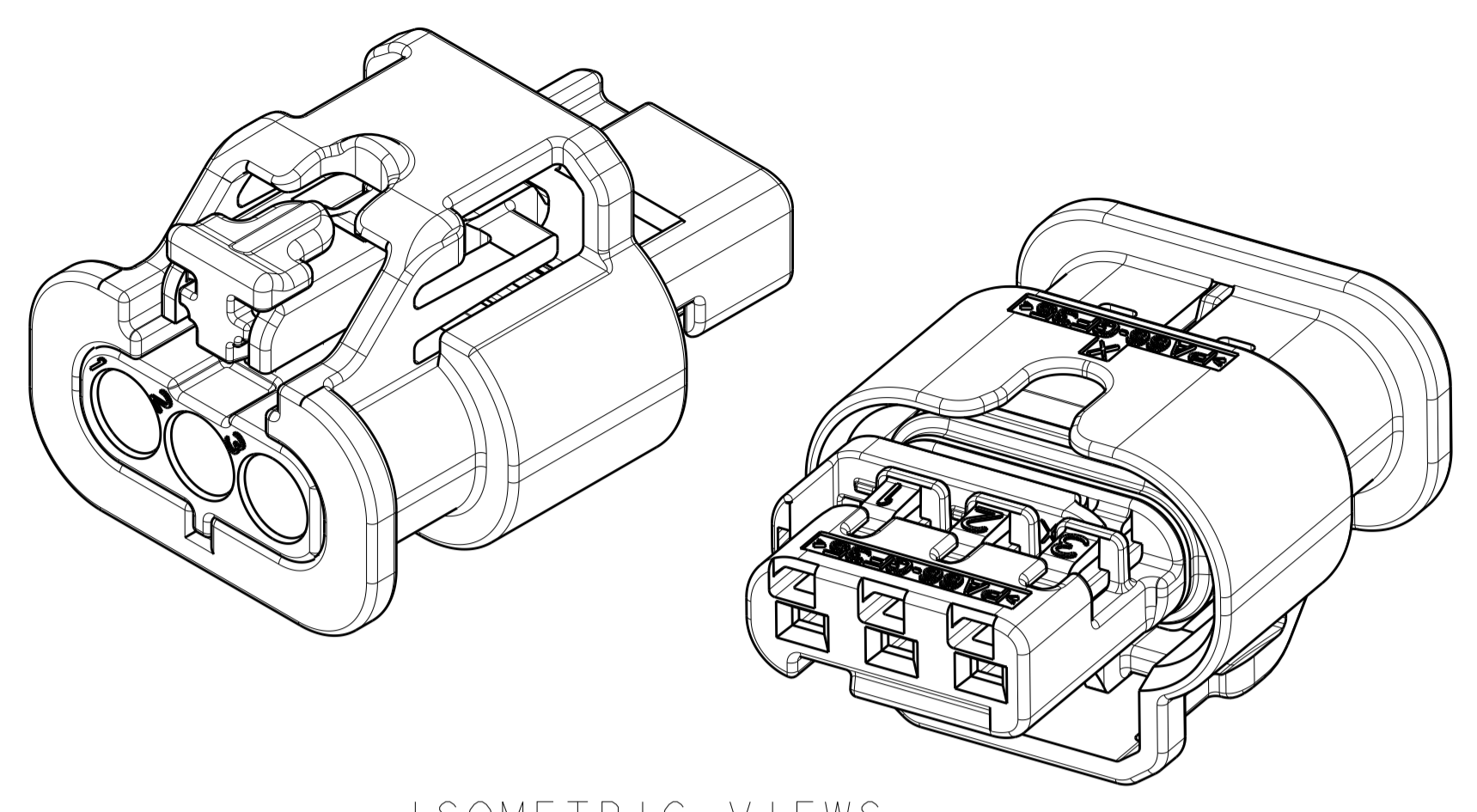

ISOMETRIC VIEWS

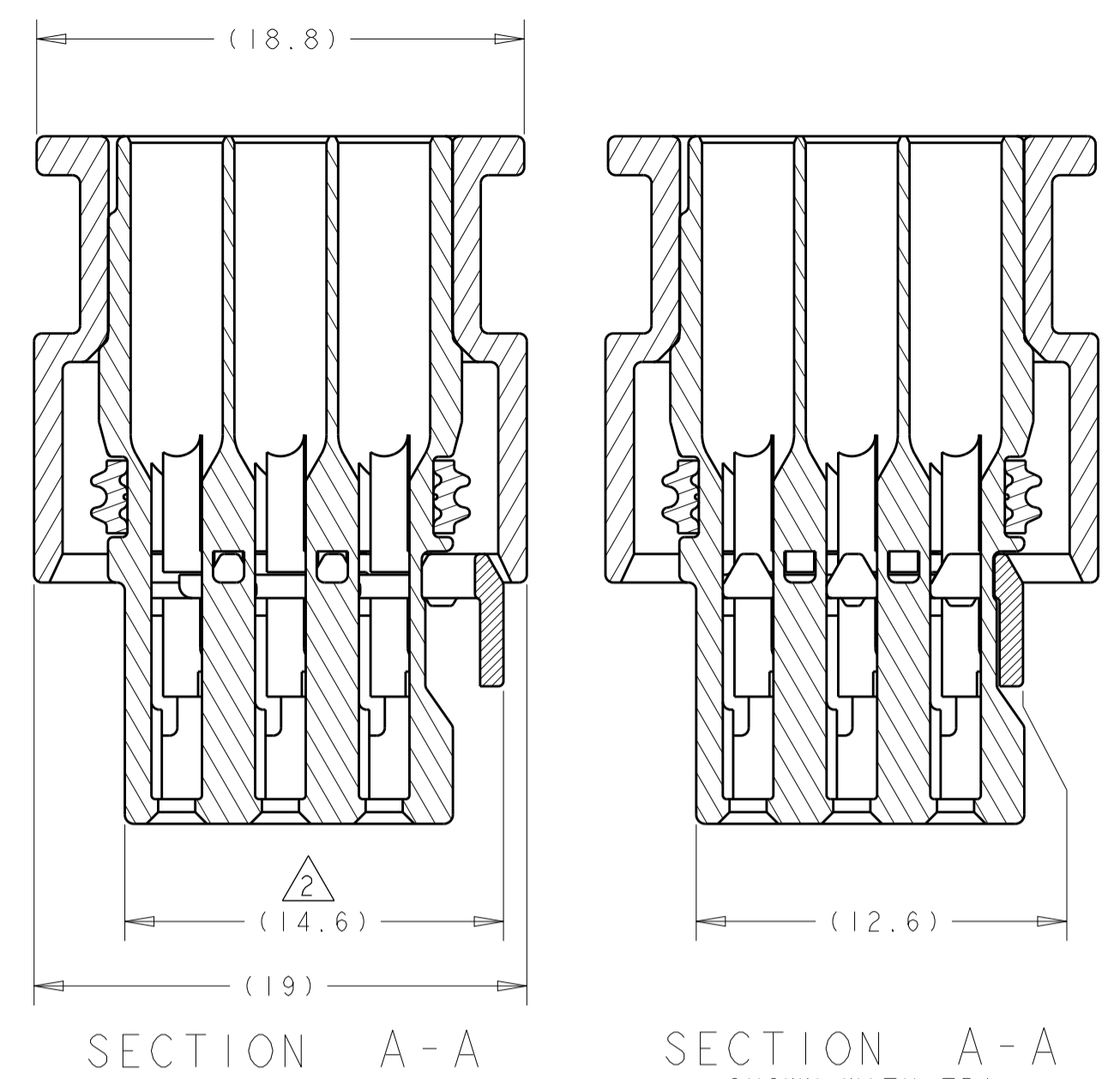

SECTION A-A  
SECTION A-A SHOWN WITH TPA IN ITS LATCHED POSITION FOR REFERENCE ONLY

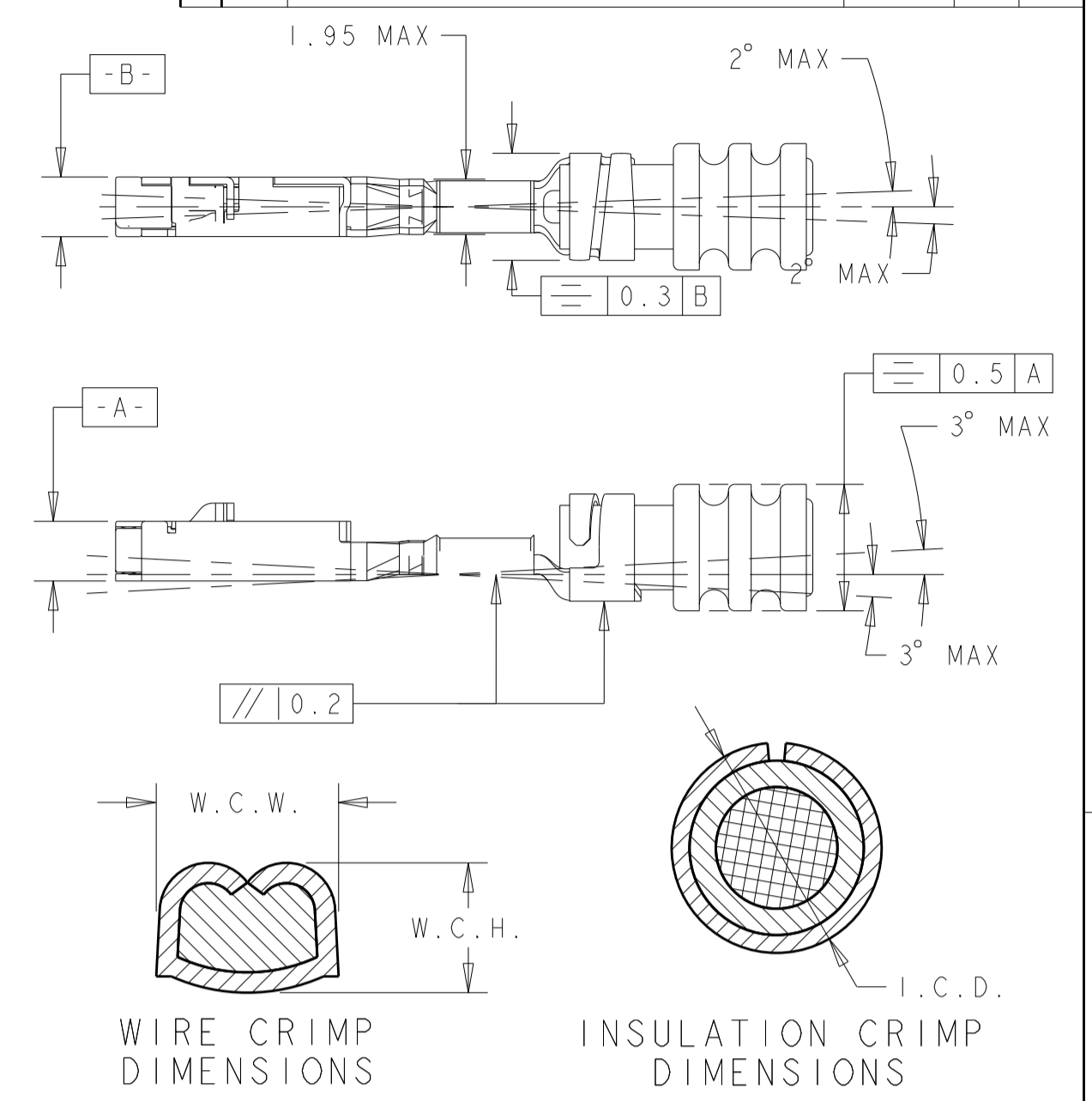

WIRE CRIMP DIMENSIONS  
INSULATION CRIMP DIMENSIONS

REVISIONS				
P. LTM	DESCRIPTION	DATE	OWN	APVD
A3	REVISED PER ECO-12-011350	19JUN2012	DLD	SLM
A4	REVISED PER ECO-15-002909	25FEB2015	DLD	SLM
A5	REVISED PER ECO-20-002102	17FEB2020	JMS	S1

KEYING CONFIGURATIONS	TERMINAL CAVITY CONFIGURATIONS
KEYING OPTION A	ALL TERMINAL CAVITIES OPEN
KEYING OPTION B	TERMINAL CAVITY #3 CLOSED
KEYING OPTION C	TERMINAL CAVITY #2 CLOSED
KEYING OPTION D	TERMINAL CAVITY #1 CLOSED

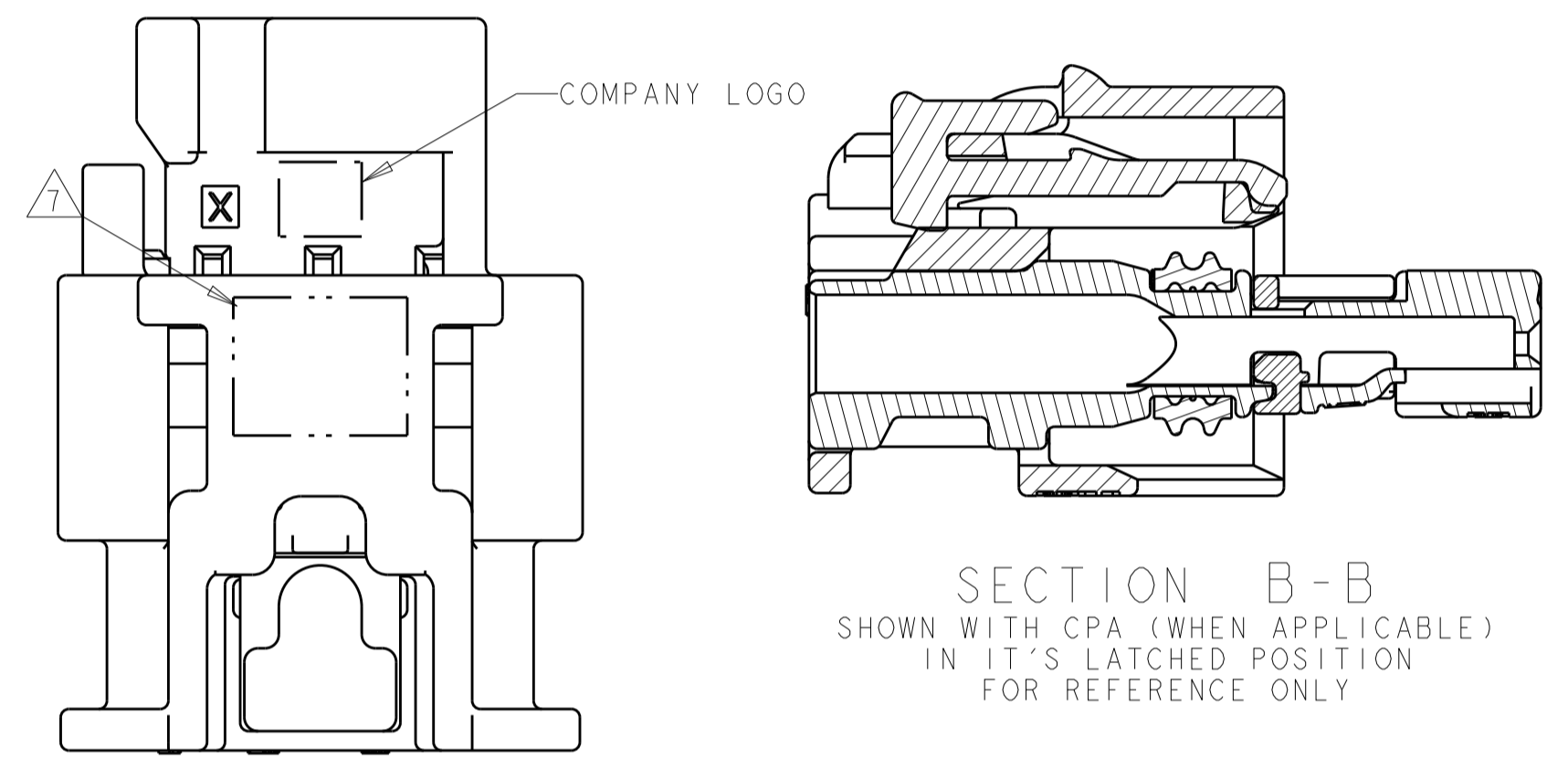

SECTION B-B  
SHOWN WITH CPA (WHEN APPLICABLE) IN ITS LATCHED POSITION FOR REFERENCE ONLY

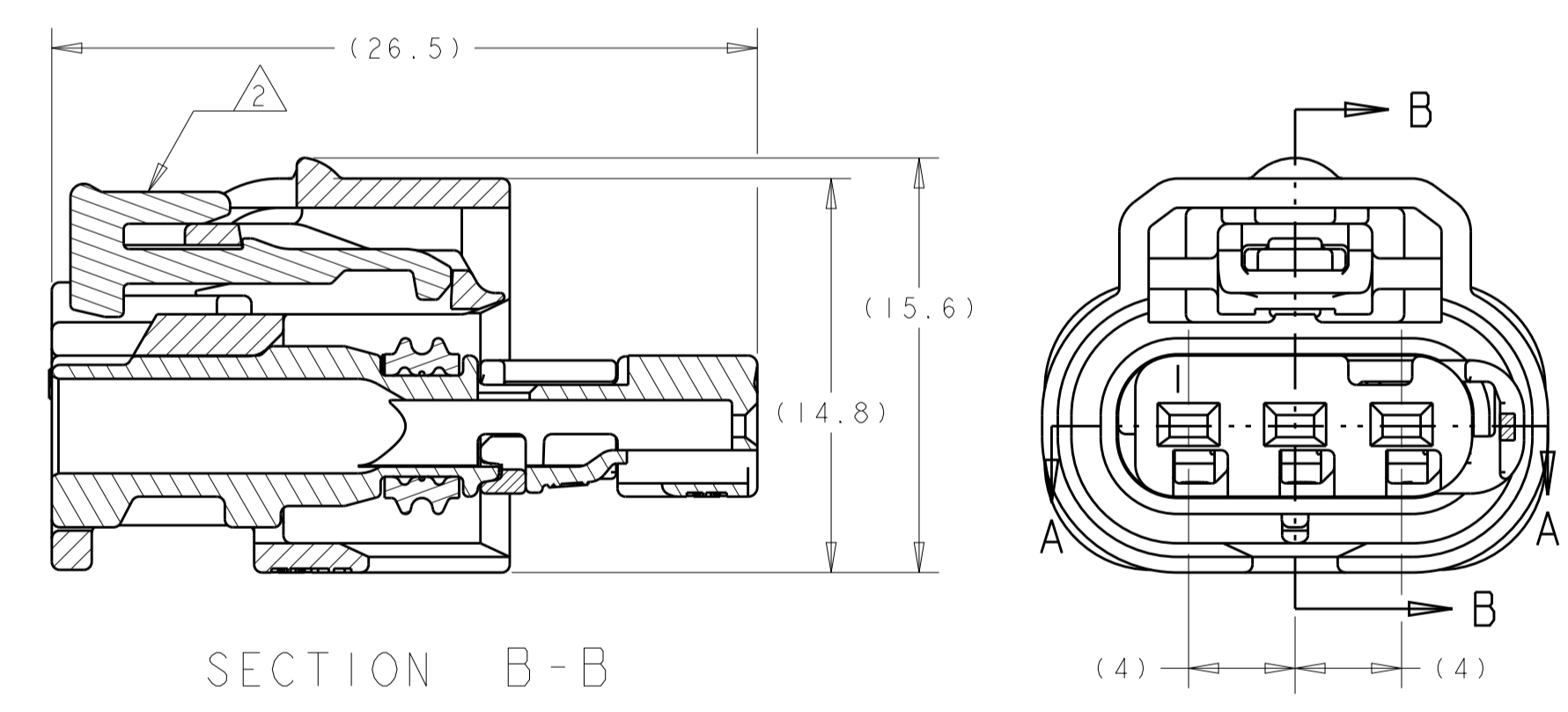

SECTION B-B

MAX TEMP	FEMALE TERMINAL PN	TERMINAL PLATING	AWG	APPLICABLE WIRE FINISHED O.D.	W.C.H.	W.C.W.	I.C.D.	WIRE SEAL PART NUMBER
125C	1418844-3	TIN	22	1.20 - 1.40mm	0.86 ±0.03	1.27 ±0.05	3.15 ±0.05	967067-2
125C	1418844-2	GOLD	22	1.20 - 1.40mm	0.86 ±0.03	1.27 ±0.05	3.15 ±0.05	967067-2
125C	1418844-1	SILVER	22	1.20 - 1.40mm	0.86 ±0.03	1.27 ±0.05	3.15 ±0.05	967067-2
125C	1670146-1	TIN	20	1.40 - 1.90mm	0.84 ±0.03	1.57 ±0.05	3.25 ±0.05	967067-1
125C	1670146-2	GOLD	20	1.40 - 1.90mm	0.84 ±0.03	1.57 ±0.05	3.25 ±0.05	967067-1
125C	1670146-3	SILVER	20	1.40 - 1.90mm	0.84 ±0.03	1.57 ±0.05	3.25 ±0.05	967067-1
125C	1418850-1	TIN	18	1.90 - 2.40mm	1.11 ±0.05	1.78 ±0.05	3.35 ±0.05	964972-1
125C	1418850-1	TIN	16	1.90 - 2.40mm	1.31 ±0.05	1.78 ±0.05	3.35 ±0.05	964972-1
125C	1418850-2	GOLD	18	1.90 - 2.40mm	1.11 ±0.05	1.78 ±0.05	3.35 ±0.05	964972-1
125C	1418850-2	GOLD	16	1.90 - 2.40mm	1.31 ±0.05	1.78 ±0.05	3.35 ±0.05	964972-1
125C	1418850-3	SILVER	18	1.90 - 2.40mm	1.11 ±0.05	1.78 ±0.05	3.35 ±0.05	964972-1
125C	1418850-3	SILVER	16	1.90 - 2.40mm	1.31 ±0.05	1.78 ±0.05	3.35 ±0.05	964972-1
150C	1670146-2	GOLD	20	1.40 - 1.90mm	0.84 ±0.03	1.57 ±0.05		2098582-1
150C	1670146-3	SILVER	20	1.40 - 1.90mm	0.84 ±0.03	1.57 ±0.05		2098582-1
150C	1418850-2	GOLD	18	1.40 - 1.90mm	1.11 ±0.05	1.78 ±0.05		2098582-1
150C	1418850-2	GOLD	16	1.40 - 1.90mm	1.31 ±0.05	1.78 ±0.05		2098582-1
150C	1418850-3	SILVER	18	1.40 - 1.90mm	1.11 ±0.05	1.78 ±0.05		2098582-1
150C	1418850-3	SILVER	16	1.40 - 1.90mm	1.31 ±0.05	1.78 ±0.05		2098582-1

STATUS	CPA	9	COLOR	KEY	CAVITY 1	CAVITY 2	CAVITY 3	PART NUMBER
RELEASED			BROWN	D	O	O	O	4-2098541-4
RELEASED			BROWN	C	O	O	O	4-2098541-3
RELEASED			BROWN	B	O	O	O	4-2098541-2
RELEASED			BROWN	A	O	O	O	4-2098541-1
PRELIMINARY			BROWN	D				3-2098541-2
			BROWN	C	X	O	O	3-2098541-1
			BROWN	B				3-2098541-0
			BROWN	A				2-2098541-9
PRELIMINARY			BROWN	D				2-2098541-8
			BROWN	C	X	O	O	2-2098541-7
			BROWN	B				2-2098541-6
			BROWN	A				2-2098541-5
PRELIMINARY			BROWN	D				2-2098541-4
			BROWN	C	O	X	O	2-2098541-3
			BROWN	B				2-2098541-2
			BROWN	A				2-2098541-1
PRELIMINARY			BROWN	D				2-2098541-0
			BROWN	C	O	X	O	1-2098541-9
			BROWN	B				1-2098541-8
			BROWN	A				1-2098541-7
PRELIMINARY			BROWN	D				1-2098541-6
			BROWN	C	O	O	X	1-2098541-5
			BROWN	B				1-2098541-4
			BROWN	A				1-2098541-3
PRELIMINARY			BROWN	D				1-2098541-2
			BROWN	C	O	O	X	1-2098541-1
			BROWN	B				1-2098541-0
			BROWN	A				2098541-9
RELEASED			BROWN	D				2098541-8
RELEASED			BROWN	C				2098541-7
RELEASED			BROWN	B	O	O	O	2098541-6
RELEASED			BROWN	A				2098541-5
RELEASED			BROWN	D				2098541-4
RELEASED			BROWN	C				2098541-3
RELEASED			BROWN	B	O	O	O	2098541-2
RELEASED			BROWN	A				2098541-1

THIS DRAWING IS A CONTROLLED DOCUMENT.

OWN: D. DRUMMOND 08OCT2009  
 CHG: S. MANKARYOS 08OCT2009  
 APVD: S. MANKARYOS 08OCT2009

TE Connectivity  
**STE**  
 CONNECTOR ASSEMBLY, FEMALE, 3 POSITION SEALED, 1.2mm STANDARD LATCH VERSION, CLASS 4

APPLICATION SPEC: IS 408-8928  
 WEIGHT: 3.0 GRAMS  
 CUSTOMER DRAWING: A100779C=2098541

SCALE: 4:1 SHEET 1 OF 2 REV A5

REVISIONS				
P.	LTN	DESCRIPTION	DATE	APVD
-	-	SEE SHEET 1	-	-

ISOMETRIC VIEWS

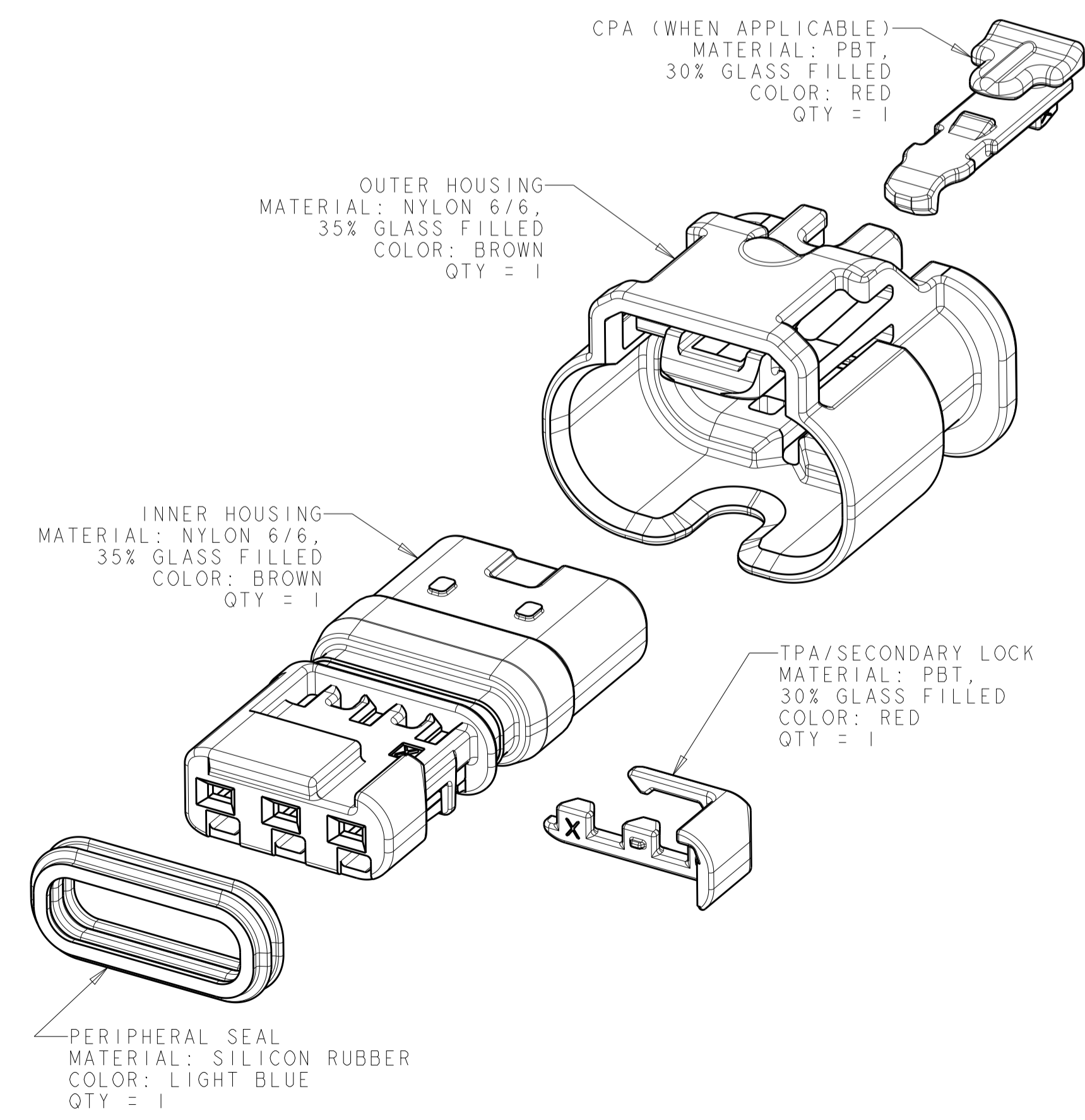
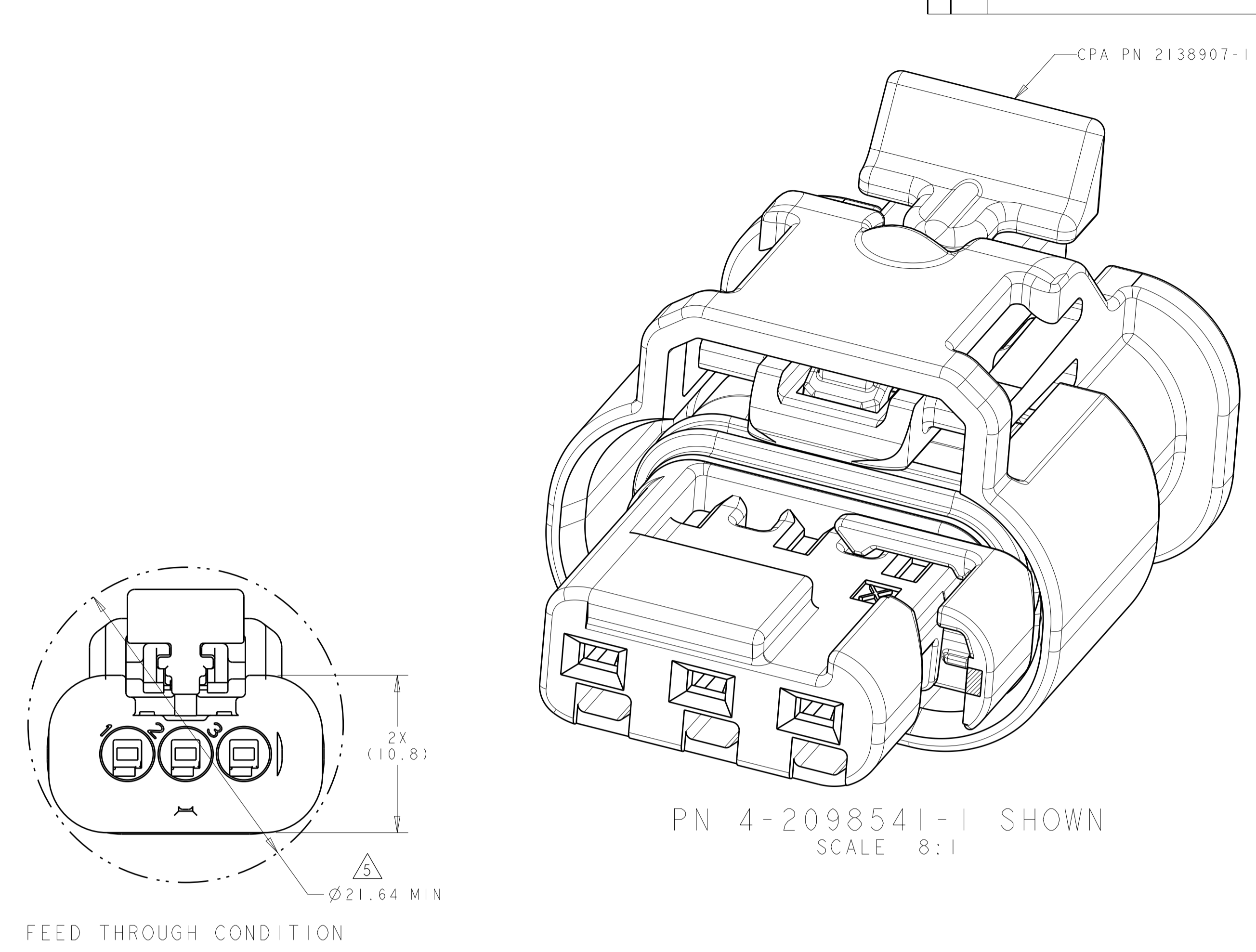
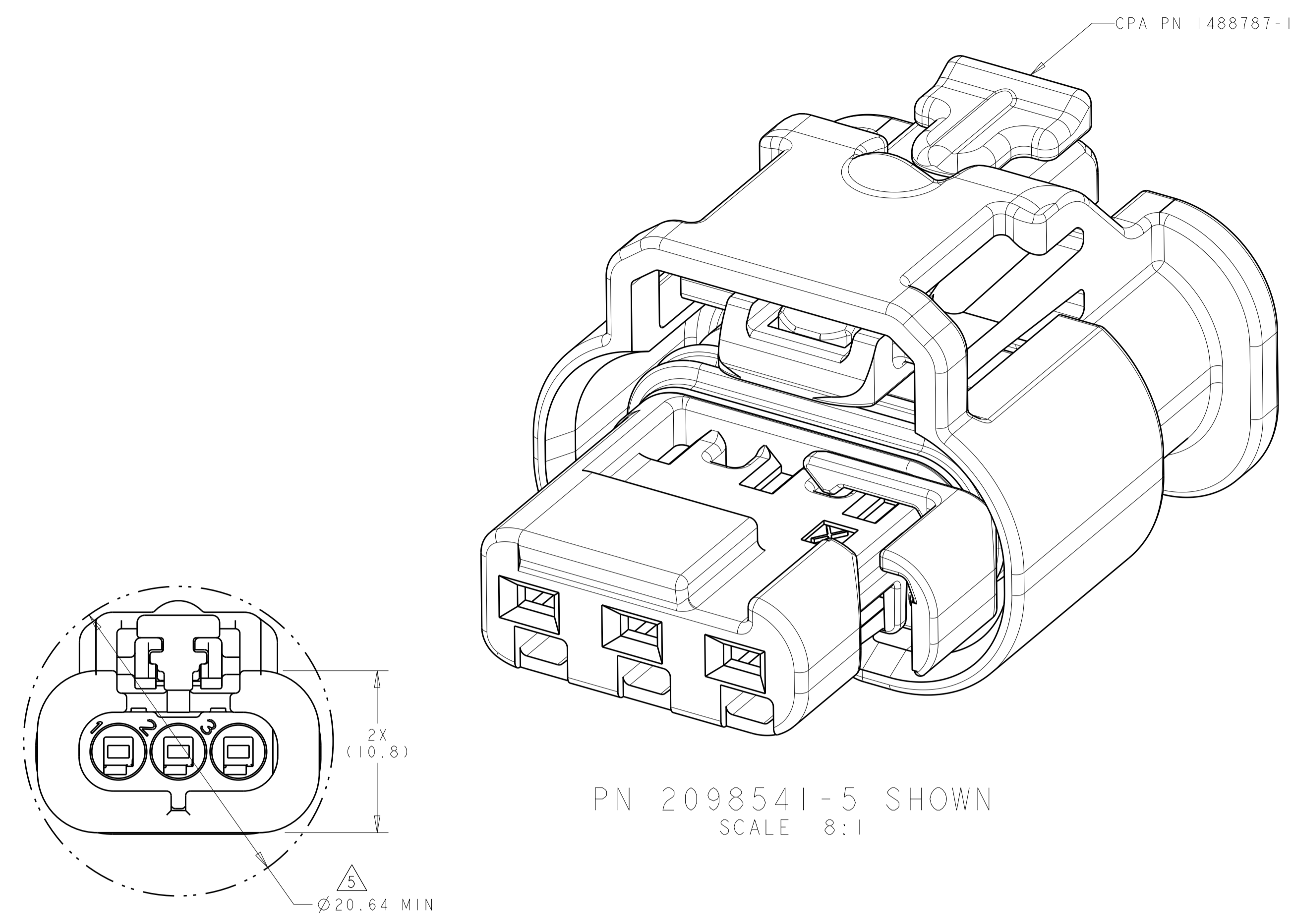

EXPLODED ISOMETRIC VIEW

THIS DRAWING IS A CONTROLLED DOCUMENT.		DWN: D. DRUMMOND 08OCT2009	
DIMENSIONS: mm		CHK: S. MANKARYOS 08OCT2009	
TOLERANCES UNLESS OTHERWISE SPECIFIED:		APVD: S. MANKARYOS 08OCT2009	NAME: CONNECTOR ASSEMBLY, FEMALE, 3 POSITION SEALED, 1.2mm STANDARD LATCH VERSION, CLASS 4
0 PLC	±	PRODUCT SPEC	SIZE: CAGE CODE DRAWING NO
1 PLC	±0.3	APPLICATION SPEC	RESTRICTED TO
2 PLC	±0.10	IS 408-8928	SCALE: 4:1
3 PLC	±	WEIGHT: 3.0 GRAMS	SHEET 2 OF 2
4 PLC	±	CUSTOMER DRAWING	REV: A5
ANGLES	±1°		
MATERIAL			
SEE TABLE			