

注記 NOTES

- 製品詳細寸法については製品単体図面を参照下さい。
FOR DETAIL OF CONNECTOR DIMENSIONS,
PLEASE SEE THE DRAWING OF CONNECTOR ITSELF (NOT PACKAGED).
- 梱包数量: 3000 個/リール
NUMBER OF CONNECTORS : 3000PCS/REEL
- リードテープ長さ LEAD TAPE LENGTH

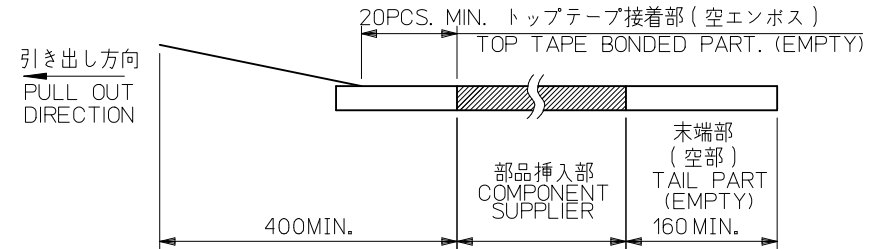

- トップテープの剥離強度: 0.1N~1.3N(10gf~130gf)
(剥離方向は下図参照)
尚、本規格値は出荷時に適用。(但し、輸送時に剥離が発生しないこと。)
PEELING OFF FORCE OF TOP TAPE : 0.1N~1.3N(10gf~130gf)
(PEELING DIRECTION AS SHOWN IN FOLLOWING FIG.)
THIS REQUIREMENT SHOULD BE APPLIED AT SHIPMENT.
PEEL OFF SHOULD NOT BE ALLOWED , DURING TRANSPORTION.

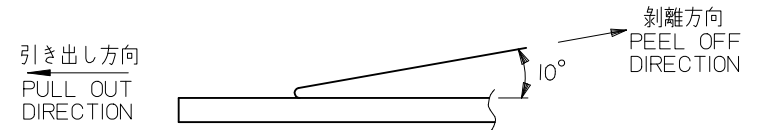

- 材料 MATERIAL
キャリアテープ (CARRIER TAPE): ポリスチレン (POLYSTYRENE)
トップテープ (TOP TAPE): PET, PE, PEF
リール (REEL): ポリスチレン (PS) <リサイクル材を含む>
POLYSTYRENE (PS) <RECYCLE MATERIAL CONTAINED>
- ELV 及び RoHS 適合品
ELV AND RoHS COMPLIANT

10 9 8 7 6 5 4 3 2 1

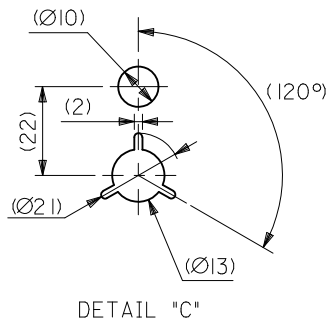
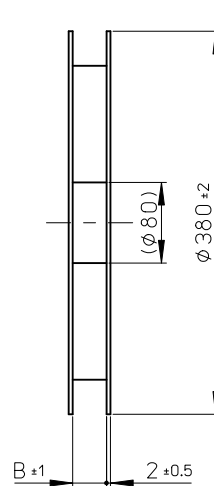
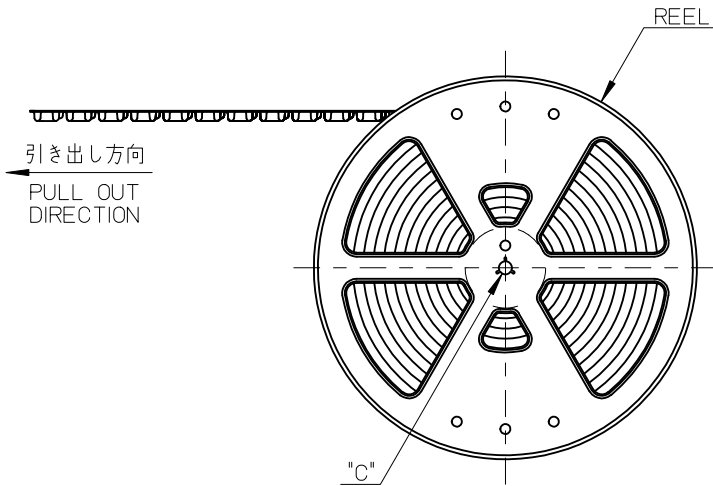

RELEASED EC NO.: J2012-0687 DRWN:MYOSHIDA 2011/11/25 CHKD:TASAKAWA 2011/11/25 APPR:MSASAO 2011/11/30	DESCRIPTION REV A	GENERAL TOLERANCES (UNLESS SPECIFIED)		DIMENSION STYLE MM ONLY		SCALE ---	DESIGN UNITS METRIC	MODEL NO. 503108-**70	
		10 UNDER	±---	DRAWN BY TTANIGUCHI	DATE 2009/01/27	TITLE 0.4 B-T0-B CONN. HGT=1.5 PLUG ASSY EMBSTP PKG CHECKER TYPE			
		10 OVER 30 UNDER	±---	CHECKED BY THIRATA	DATE 2009/01/27	MOLEX INCORPORATED			
		30 OVER	±---	APPROVED BY MSASAO	DATE 2009/01/27				
ANGULAR ±---°		DRAFT WHERE APPLICABLE MUST REMAIN WITHIN DIMENSIONS		MATERIAL NO. SEE CHART		DOCUMENT NO. SD-503108-004		SHEET NO. 1 OF 2	
THIS DRAWING CONTAINS INFORMATION THAT IS PROPRIETARY TO MOLEX INCORPORATED AND SHOULD NOT BE USED WITHOUT WRITTEN PERMISSION									

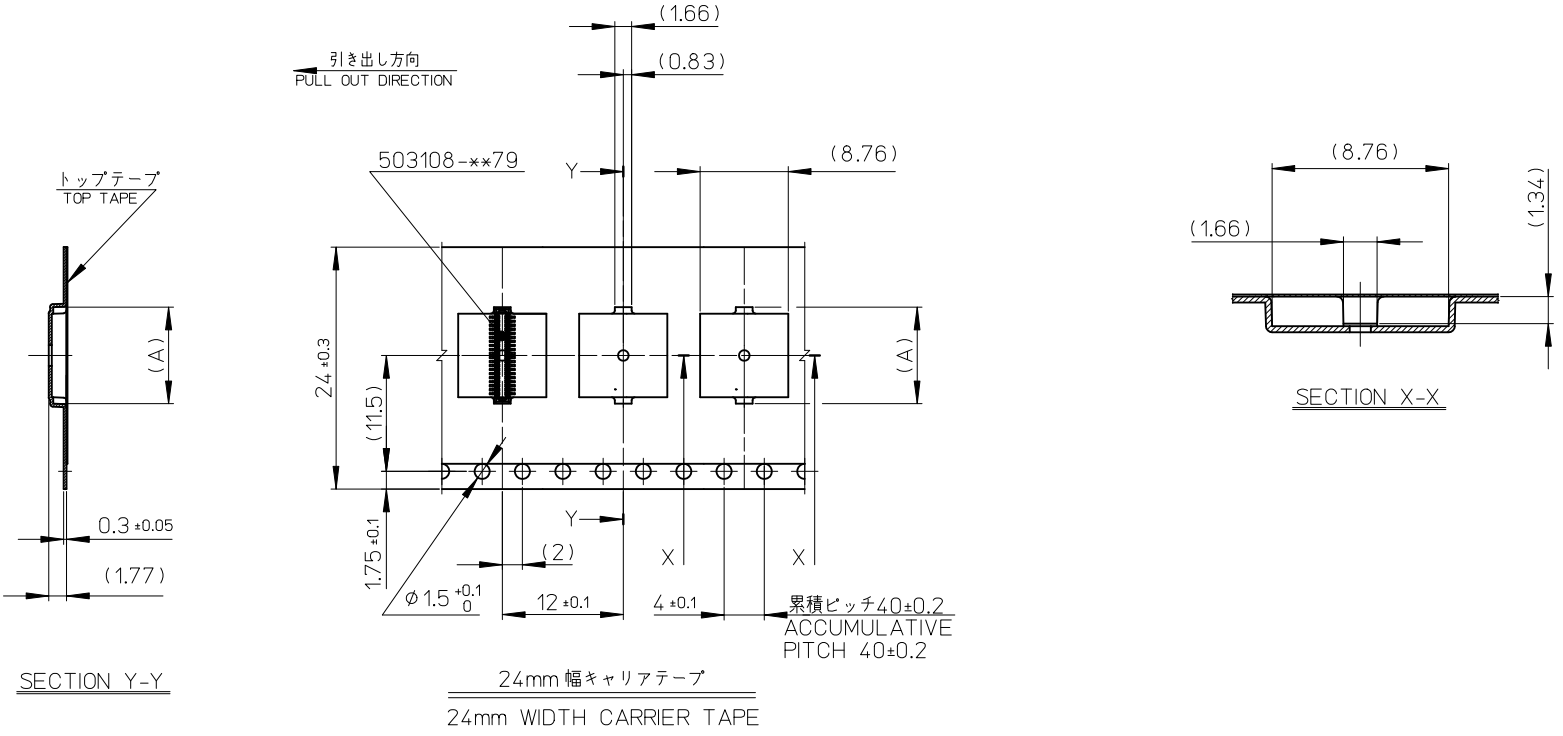

SECTION Y-Y

SECTION X-X

24mm 幅キャリアテープ
24mm WIDTH CARRIER TAPE

24	25.5	11.58	503108-5070	50	
		10.38	503108-4470	44	
		9.58	503108-4070	40	
キャリアテープ幅 CARRIER TAPE WIDTH		B	(A)	MATERIAL No.	CKT.
			MODEL No.	503108-**-70	

REVISED EC NO: J2012-0687 DRWN: MYOSHIDA 2011/11/25 CHKD: TASAKAWA 2011/11/25 APPR: MSASAO 2011/11/30	DESCRIPTION	GENERAL TOLERANCES (UNLESS SPECIFIED)		DIMENSION STYLE		SCALE	DESIGN UNITS	THIRD ANGLE PROJECTION		
				MM ONLY			METRIC			
		10 UNDER	±---	DRAWN BY	DATE	TITLE				
		10 OVER 30 UNDER	±---	TTANIGUCHI	01/27	0.4 B-TO-B CONN. HGT=1.5 PLUG ASSY EMBSTP PKG CHECKER TYPE				
30 OVER	±---	CHECKED BY	DATE	APPROVED BY						
		THIRATA	01/27	MSASAO 2009/01/27						
		ANGULAR ±---°		MATERIAL NO.		DOCUMENT NO.		SHEET NO.		
		DRAFT WHERE APPLICABLE MUST REMAIN WITHIN DIMENSIONS		SEE CHART		SD-503108-004		2 OF 2		
A	REV	THIS DRAWING CONTAINS INFORMATION THAT IS PROPRIETARY TO MOLEX INCORPORATED AND SHOULD NOT BE USED WITHOUT WRITTEN PERMISSION								