

# DPM 950S-EB

## 3½ Digit LCD Voltmeter

### ORDERING INFORMATION

Description	Stock No.
Blue Backlighting	DPM 950S-EB-B
Green Backlighting	DPM 950S-EB-G
Magenta Backlighting	DPM 950S-EB-M
Orange Backlighting	DPM 950S-EB-O
Red Backlighting	DPM 950S-EB-R
White Backlighting	DPM 950S-EB-W
Yellow Backlighting	DPM 950S-EB-Y

### FEATURES

- 19mm (0.75") Digit Height
- IDC Interface
- Auto-zero
- Auto-polarity
- 200mV d.c. Full Scale Reading (F.S.R.)
- Enhanced black LCD with LED Backlight
- Single Rail 5V d.c. Supply
- Alarm Annunciator



The DPM 950S-EB-W features an enhanced black LCD and 200mV d.c. measurement range with auto-zero and auto-polarity. Decimal points are user selectable. The DPM 950S-EB-W features a negative rail generator which enables the meter to measure a signal referenced to its own power supply GND. Enhanced contrast negative mode LCD with white LED backlighting ensures excellent readability under all light conditions. The meter is housed in a robust carrier, which can be bolted in place or panel mounted using the bezel, window and clips provided.

### CONNECTOR SOURCING GUIDE

METHOD	Cable Mounting IDC Supplied With Product
--------	--

### DIMENSIONS All dimensions in mm (inches)

Panel cut-out 72 x 40 (2.83 x 1.57)  
Maximum panel thickness 3mm (0.12).

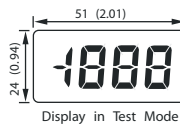
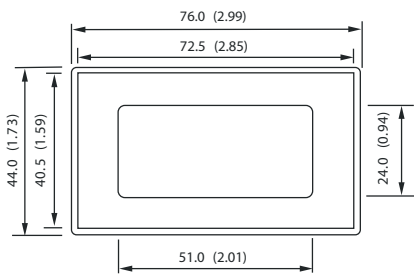

- Display in Test Mode
- a. 1.0 (0.04)
  - b. 2.0 (0.08)
  - c. 6.5 (0.26)
  - d. 11.5 (0.45)
  - e. 8.4 (0.33)\*

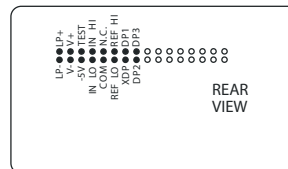

\*typical depth of tallest component behind PCB, this dimension is for guidance only.

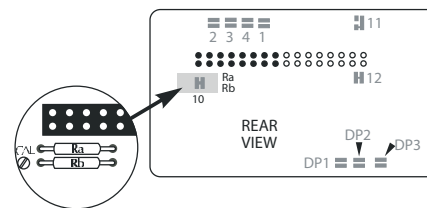
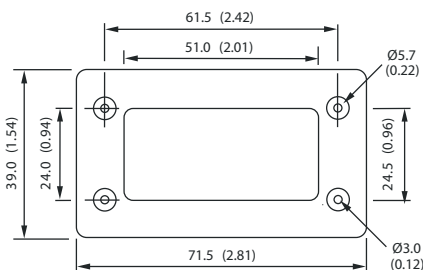

ON BOARD SOLDER LINKS  
SCALING RESISTORS

Specifications	Min.	Typ.	Max.	Unit
Accuracy (overall error) *		0.05	0.1	% ( $\pm 1$ count)
Linearity			$\pm 1$	count
Sample rate		3		samples/sec
Operating temperature range	0		50	$^{\circ}\text{C}$
Temperature stability		100		ppm/ $^{\circ}\text{C}$
Supply voltage	4.75	5	7.5 **	V d.c.
Supply current	Display on	50	90 ***	mA
	Display disabled	500		$\mu\text{A}$
Input leakage current ( $V_{in} = 0\text{V}$ )		1	10	pA

\* To ensure maximum accuracy, re-calibrate periodically.

\*\* Operation of the meter beyond the maximum supply voltage rating can cause permanent damage to the meter.

\*\*\* An external series resistor is required above 5V, see Applications. This specification linearly derates to 30mA @ 50  $^{\circ}\text{C}$ .

## PIN FUNCTIONS

1. LP- Negative power supply to LED backlighting. Connect to 0V (Pin 3)
  2. LP+ Positive power supply to LED backlighting. +5V connect to V+ for 5V supply, or via external resistor if V+ is above 5V. See Applications.
  3. V- Negative power supply connection. 0V.
  4. V+ Positive power supply connection. (+5V nom)
  5. -5V N.C. (Output from negative rail generator circuit. This output is an inversion of V+).
  6. TEST Connect to V+ to display all segments except DPs. It should not be operated for more than a few seconds as the D.C. voltage applied to the LCD may 'burn' the display. This pin is normally at 5V below V+ and is the ground for the digital section of the meter. It can be used to power external logic up to a maximum of 1mA.
  7. IN LO Negative measuring differential input. Analogue inputs must be no closer than 1V to either positive or negative supply. The negative
  8. IN HI Positive measuring differential input. supply of the DPM 950S is generated internally and mirrors the positive supply voltage.
  9. COM Ground for the analogue section of the A/D converter, it is actively held at approximately 2.8V below V+ and must not be allowed to sink excessive current ( $>100 \mu\text{A}$ ) by, for instance, connecting to a higher voltage.
  11. REF LO Negative input for reference voltage. Can be connected to COM via link 3.
  12. REF HI Positive input for reference voltage. Connected via link 1 to internal reference.
  13. XDP Annunciator Drive Waveform, this is an inversion of the backplane.
  14. DP1 199.9
  15. DP2 19.99
  16. DP3 1.999
- } Connect to V+ to display required Decimal Point or short corresponding DP link.
- 18 & 32. BP LCD backplane drive waveform.
  23. REF- Negative output from internal reference.
  24. REF+ Positive output from internal reference.
  25. LO BAT Used to control the low battery annunciator externally, cut link 12 and take to V+ to turn on annunciator. The annunciator turn on point can also be set by adjusting the BAT potentiometer (R10), in which case do not connect to this pin and leave link 12 intact.
  26. REF BG Output from internal bandgap reference. (Factory fitted option.)
  27.  Alarm annunciator, cut link ALM and take to XDP to display.
  28. : Colon annunciator, cut link COL and take to XDP to display.
  29. - Polarity annunciator, connected via link 11 to polarity output of IC1. Cut link 11 and either take to XDP to display or make other side of link 11 to hold off.
  30. POL Polarity output of IC1.
  31. CLK May be used to override the internal oscillator and control the sample rate. Link 14 must then be made.
- Only Pins 1-16 are fitted, these functions are available but a connector is not provided.

## SAFETY

To comply with the Low Voltage Directive (LVD 93/68/EEC), input voltages to the module's pins must not exceed 60Vdc. If voltages to the measuring inputs do exceed 60Vdc, then fit scaling resistors externally to the module. The user must ensure that the incorporation of the DPM into the user's equipment conforms to the relevant sections of BS EN 61010 (Safety Requirements for Electrical Equipment for Measuring, Control and Laboratory Use)

## VARIOUS OPERATING MODES

**ON-BOARD LINKS:** In order to quickly and easily change operating modes for different applications, the meter has several on-board links. They are designed to be easily opened (cut) or shorted (soldered).

Do not connect more than one meter to the same power supply if the meters cannot use the same signal ground. Taking any input beyond the power supply rails will damage the meter.

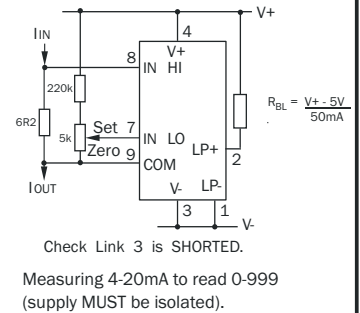
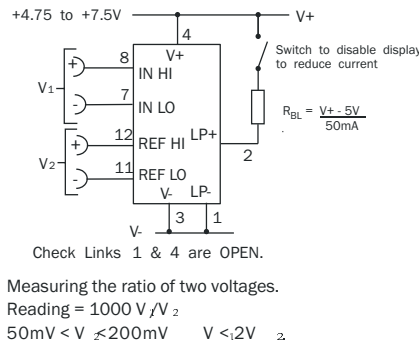
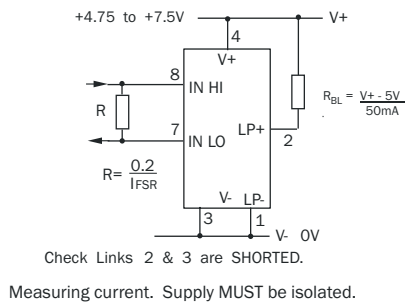
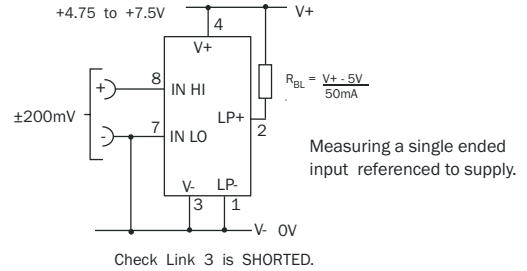
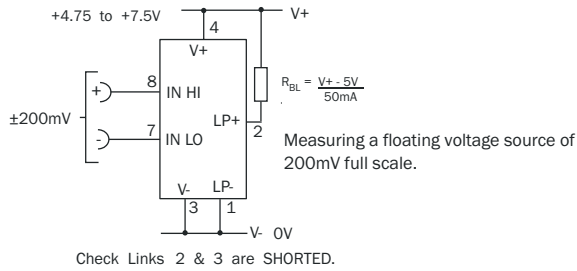

## SCALING

Two resistors Ra and Rb may be fitted in order to alter the full scale reading (F.S.R.) of the meter - see table.

The meter will need re-calibration.

Required F.S.R.		Ra	Rb
2V	Note	910k	100k
20V	Note	1M	10k
200V	Note	1M	1k
2kV	Note	1M	100R
200µA		LINK	1k
2mA		LINK	100R
20mA		LINK	10R
200mA		LINK	1R

### NOTE

Ensure that Link 10 is open if fitting Ra.

Module House  
Whiteparish, Salisbury  
Wiltshire SP5 2SJ  
UK  
T +44 (1794) 884567  
F +44 (1794) 884616  
E sales@lascarelectronics.com

4258 West 12th Street  
Erie  
PA 16505  
USA  
T +1 (814) 835 0621  
F +1 (814) 838 8141  
E us-sales@lascarelectronics.com

8th Floor, China Aerospace Centre  
143 Hoi Bun Road  
Kwun Tong, Kowloon  
HONG KONG  
T +852 2797 3219  
F +852 2343 6187  
E saleshk@lascarelectronics.com

www.lascarelectronics.com

