



CURIE BASED WEARABLE

General Description

Silego SLG7NT41502 is a low power and small form device. The SoC is housed in a 1.6 x 2.0 mm STQFN package which is optimal for using with small devices.

Features

- Low Power Consumption
- Pb-Free / RoHS Compliant
- Halogen-Free
- STQFN-14 Package

Output Summary

- 1 Output — Push Pull 2X
- 1 Output — Open Drain NMOS 1X
- 3 Outputs — Open Drain NMOS 2X

Pin Configuration

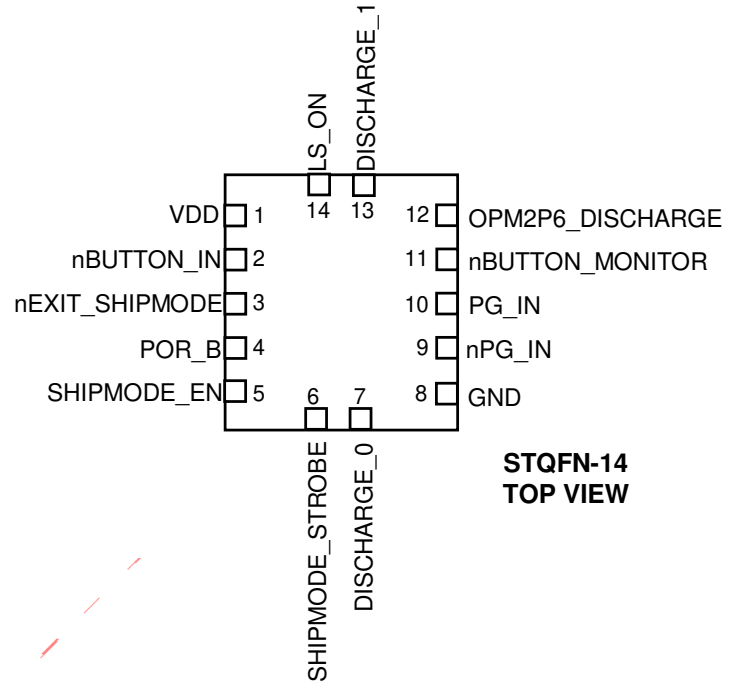



Pin Configuration

Pin #	Pin Name	Type	Pin Description
1	VDD	PWR	Supply Voltage
2	nBUTTON_IN	Digital Input	Digital Input with Schmitt trigger
3	nEXIT_SHIPMODE	Digital Input	Digital Input with Schmitt trigger
4	POR_B	Digital Input	Low Voltage Digital input
5	SHIPMODE_EN	Digital Input	Low Voltage Digital input
6	SHIPMODE_STROBE	Digital Input	Low Voltage Digital input
7	DISCHARGE_0	Digital Output	Open Drain NMOS 2X
8	GND	GND	Ground
9	nPG_IN	Digital Input	Digital Input with Schmitt trigger
10	PG_IN	Digital Input	Digital Input with Schmitt trigger
11	nBUTTON_MONITOR	Digital Output	Open Drain NMOS 1X
12	OPM2P6_DISCHARGE	Digital Output	Open Drain NMOS 2X
13	DISCHARGE_1	Digital Output	Open Drain NMOS 2X
14	LS_ON	Digital Output	Push Pull 2X

Ordering Information

Part Number	Package Type
SLG7NT41502V	V=STQFN-14
SLG7NT41502VTR	STQFN-14 – Tape and Reel (3k units)



Absolute Maximum Conditions

Parameter	Min.	Max.	Unit
V _{HIGH} to GND	-0.3	7	V
Voltage at input pins	-0.3	7	V
Current at input pin	-1.0	1.0	mA
Storage temperature range	-65	125	°C
Junction temperature	--	150	°C
ESD Protection (Human Body Model)	2000	--	V
ESD Protection (Charged Device Model)	1000	--	V
Moisture Sensitivity Level	1		

Electrical Characteristics

(@ 25°C, unless otherwise stated)

Symbol	Parameter	Condition/Note	Min.	Typ.	Max.	Unit
V _{DD}	Supply Voltage		1.71	3.6	5.5	V
T _A	Operating Temperature		-40	25	85	°C
I _Q	Quiescent Current	Static inputs and floating outputs PIN4 = 1; PIN14 = 1; DFF4 = 0 @VDD = 3.3V	--	1	--	μA
		Static inputs and outputs PIN4 = 0; PIN14 = 0; DFF4 = 1 @VDD = 3.3V	--	1	--	
		Static inputs and outputs PIN4 = 1; PIN14 = 1; DFF4 = 0 @VDD = 5.5V	--	1	--	
		Static inputs and outputs PIN4 = 0; PIN14 = 0; DFF4 = 1 @VDD = 5.5V	--	1	--	
I _A	Active Current	Static outputs PIN4 = 0; PIN14 = 1; DFF4 = 0 @VDD = 3.7V	--	50	--	μA
		Static outputs PIN4 = 0; PIN14 = 0; DFF4 = 0 @VDD = 3.3V	--	1.8	--	
		Static outputs PIN4 = 0; PIN14 = 1; DFF4 = 0 @VDD = 5.5V	--	50	--	
V _O	Maximal Voltage Applied to any PIN in High-Impedance State		--	--	VDD	V
I _O	Maximal Average or DC Current (note 1)	Per Each Chip Side	--	--	90	mA
V _{IH}	HIGH-Level Input Voltage (Note 2)	Logic Input with Schmitt Trigger, at VDD=1.8V At temperature -45°C +85°C (note 1)	1.27	--	VDD	V
		Low-Level Logic Input, at VDD=1.8V At temperature -45°C +85°C (note 1)	0.98	--	VDD	
		Logic Input with Schmitt Trigger, at VDD=3.3V At temperature -45°C +85°C (note 1)	2.13	--	VDD	



CURIE BASED WEARABLE

		Low-Level Logic Input, at VDD=3.3V At temperature -45°C +85°C (note 1)	1.13	--	VDD	
		Logic Input with Schmitt Trigger, at VDD=5.0V At temperature -45°C +85°C (note 1)	3.16	--	VDD	
		Low-Level Logic Input, at VDD=5.0V At temperature -45°C +85°C (note 1)	1.23	--	VDD	
V_{IL}	LOW-Level Input Voltage (Note 2)	Logic Input with Schmitt Trigger, at VDD=1.8V	--	--	0.44	V
		Low-Level Logic Input, at VDD=1.8V At temperature -45°C +85°C (note 1)	--	--	0.52	
		Logic Input with Schmitt Trigger, at VDD=3.3V At temperature -45°C +85°C (note 1)	--	--	0.95	
		Low-Level Logic Input, at VDD=3.3V At temperature -45°C +85°C (note 1)	--	--	0.69	
		Logic Input with Schmitt Trigger, at VDD=5.0V At temperature -45°C +85°C (note 1)	--	--	1.51	
		Low-Level Logic Input, at VDD=5.0V At temperature -45°C +85°C (note 1)	--	--	0.78	
V_{HYS}	Schmitt Trigger Hysteresis Voltage	Logic Input with Schmitt Trigger	0.273	--	0.792	V
I_{IH}	HIGH-Level Input Current	Logic Input PINs; $V_{IN} = VDD$	-1.0	--	1.0	μA
I_{IL}	LOW-Level Input Current	Logic Input PINs; $V_{IN} = 0V$	-1.0	--	1.0	μA
V_{OH}	HIGH-Level Output Voltage (note 1)	Push Pull, $I_{OH} = 100\mu A$, 2X Driver, at VDD=1.8 V At temperature -45°C +85°C (note 1)	1.679	1.792	--	V
		Push Pull, $I_{OH} = 3mA$, 2X Driver, at VDD=3.3 V At temperature -45°C +85°C (note 1)	2.861	3.201	--	
		Push Pull, $I_{OH} = 5mA$, 2X Driver, at VDD=5.0 V At temperature -45°C +85°C (note 1)	4.330	4.878	--	
V_{OL}	LOW-Level Output Voltage (note 1)	Open Drain, $I_{OL} = 100\mu A$, 1X Driver, at VDD=1.8 V At temperature -45°C +85°C (note 1)	--	0.007	0.010	V
		Push Pull, $I_{OL} = 100\mu A$, 2X Driver, at VDD=1.8 V At temperature -45°C +85°C (note 1)	--	0.007	0.010	
		Open Drain, $I_{OL} = 100\mu A$, 2X Driver, at VDD=1.8 V At temperature -45°C +85°C (note 1)	--	0.002	0.010	
		Open Drain, $I_{OL} = 3mA$, 1X Driver, at VDD=3.3 V At temperature -45°C +85°C (note 1)	--	0.070	0.130	
		Push Pull, $I_{OL} = 3mA$, 2X Driver, at VDD=3.3 V At temperature -45°C +85°C (note 1)	--	0.079	0.130	



CURIE BASED WEARABLE

		Open Drain, $I_{OL} = 3\text{mA}$, 2X Driver, at $V_{DD}=3.3\text{ V}$ At temperature $-45^{\circ}\text{C} +85^{\circ}\text{C}$ (note 1)	--	0.040	0.070	
		Open Drain, $I_{OL} = 5\text{mA}$, 1X Driver, at $V_{DD}=5.0\text{ V}$ At temperature $-45^{\circ}\text{C} +85^{\circ}\text{C}$ (note 1)	--	0.090	0.160	
		Push Pull, $I_{OL} = 5\text{mA}$, 2X Driver, at $V_{DD}=5.0\text{ V}$ At temperature $-45^{\circ}\text{C} +85^{\circ}\text{C}$ (note 1)	--	0.101	0.160	
		Open Drain, $I_{OL} = 5\text{mA}$, 2X Driver, at $V_{DD}=5.0\text{ V}$ At temperature $-45^{\circ}\text{C} +85^{\circ}\text{C}$ (note 1)	--	0.050	0.080	
I_{OH}	HIGH-Level Output Current (note 1)	Push Pull & PMOS OD, $V_{OH} = V_{DD}-0.2$, 2X Driver, at $V_{DD}=1.8\text{ V}$ At temperature $-45^{\circ}\text{C} +85^{\circ}\text{C}$ (note 1)	2.069	3.390	--	mA
		Push Pull & PMOS OD, $V_{OH} = 2.4\text{ V}$, 2X Driver, at $V_{DD}=3.3\text{ V}$ At temperature $-45^{\circ}\text{C} +85^{\circ}\text{C}$ (note 1)	11.278	21.634	--	
		Push Pull & PMOS OD, $V_{OH} = 2.4\text{ V}$, 2X Driver, at $V_{DD}=5.0\text{ V}$ At temperature $-45^{\circ}\text{C} +85^{\circ}\text{C}$ (note 1)	40.059	59.691	--	
I_{OL}	LOW-Level Output Current (note 1)	Push Pull, $V_{OL} = 0.15\text{V}$, 2X Driver, at $V_{DD}=1.8\text{ V}$ At temperature $-45^{\circ}\text{C} +85^{\circ}\text{C}$ (note 1)	1.52	2.840	--	mA
		Open Drain, $V_{OL} = 0.15\text{V}$, 1X Driver, at $V_{DD}=1.8\text{ V}$ At temperature $-45^{\circ}\text{C} +85^{\circ}\text{C}$ (note 1)	1.530	2.840	--	
		Open Drain, $V_{OL} = 0.15\text{V}$, 2X Driver, at $V_{DD}=1.8\text{ V}$ At temperature $-45^{\circ}\text{C} +85^{\circ}\text{C}$ (note 1)	3.060	5.680	--	
		Push Pull, $V_{OL} = 0.4\text{V}$, 2X Driver, at $V_{DD}=3.3\text{ V}$ At temperature $-45^{\circ}\text{C} +85^{\circ}\text{C}$ (note 1)	8.130	13.840	--	
		Open Drain, $V_{OL} = 0.4\text{V}$, 1X Driver, at $V_{DD}=3.3\text{ V}$ At temperature $-45^{\circ}\text{C} +85^{\circ}\text{C}$ (note 1)	8.130	13.850	--	
		Open Drain, $V_{OL} = 0.4\text{V}$, 2X Driver, at $V_{DD}=3.3\text{ V}$ At temperature $-45^{\circ}\text{C} +85^{\circ}\text{C}$ (note 1)	16.260	23.700	--	
		Push Pull, $V_{OL} = 0.4\text{V}$, 2X Driver, at $V_{DD}=5.0\text{ V}$ At temperature $-45^{\circ}\text{C} +85^{\circ}\text{C}$ (note 1)	12.020	19.460	--	
		Open Drain, $V_{OL} = 0.4\text{V}$, 1X Driver, at $V_{DD}=5.0\text{ V}$ At temperature $-45^{\circ}\text{C} +85^{\circ}\text{C}$ (note 1)	12.030	19.460	--	
		Open Drain, $V_{OL} = 0.4\text{V}$, 2X Driver, at $V_{DD}=5.0\text{ V}$ At temperature $-45^{\circ}\text{C} +85^{\circ}\text{C}$ (note 1)	24.060	38.920	--	



CURIE BASED WEARABLE

V _{ACMP0}	Analog Comparator Threshold Voltage	Low to High transition, at temperature 25°C.	3532.7	3582.9	3633.1	mV
		Low to High transition, at temperature -40 +85°C (note 1)	3519.7	3579.8	3644.2	
		High to Low transition, at temperature 25°C	2948.8	2991.5	3034.2	
		High to Low transition, at temperature -40 +85°C (note 1)	2937.1	2988.1	3040.9	
G _{ACMP0}	Analog Comparator0 IN+ gain	ACMP 0	--	0.33	---	
V _{HYST}	Analog Comparator Hysteresis Voltage (note 1)	ACMP 0	--	200	--	mV
R _{PULL_UP}	Internal Pull Up Resistance	Pull up on PIN 2, 3	70	100	130	kΩ
R _{PULL_DOWN}	Internal Pull Down Resistance	Pull down on PINs 5, 6	70	100	130	kΩ
R _{DIS}	Discharge Resistance	External resistor on PIN7, PIN12 and PIN13	270	--	--	Ω
T _{CNT0}	Counter0 Period (WS Ctrl)	At temperature 25°C	153.14	176.87	207.44	ms
		At temperature -40°C +85°C (note 1)	153.14	178.87	217.81	
T _{DLY1}	Delay1 Time	At temperature 25°C	195.04	200.45	206.90	ms
		At temperature -40°C +85°C (note 1)	184.59	200.45	216.47	
T _{DLY2}	Delay2 Time	At temperature 25°C	486.52	500.02	516.10	ms
		At temperature -40°C +85°C (note 1)	460.44	500.02	539.10	
T _{DLY3}	Delay3 Time	At temperature 25°C	195.04	200.45	206.90	ms
		At temperature -40°C +85°C (note 1)	184.59	200.45	216.47	
T _{SU}	Start up Time	From VDD rising past PON _{THR}	0.462	1.4	4.999	ms
PON _{THR}	Power On Threshold	VDD Level Required to Start Up the Chip	0.961	1.312	1.659	V
POFF _{THR}	Power Off Threshold	VDD Level Required to Switch Off the Chip	0.875	1.109	1.288	V

1. Guaranteed by Design.
2. No hysteresis for Low Voltage Digital Input

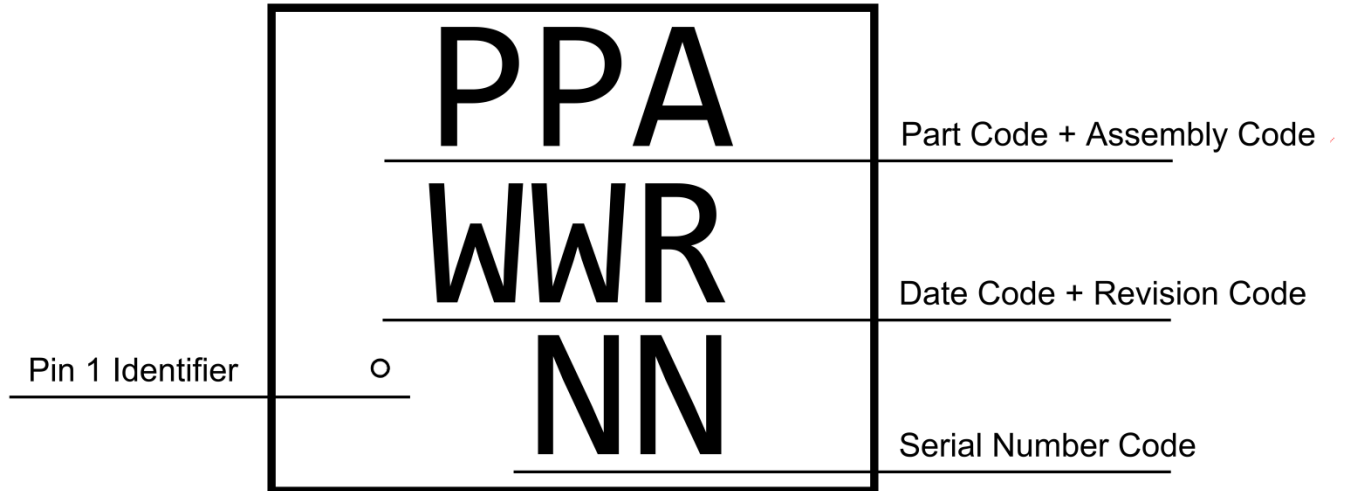

Datasheet Revision	Programming Code Number	Locked Status	Part Code	Revision	Date
1.04	002	L	V6	B	01/23/2017

The IC security bit is locked/set for code security for production unless otherwise specified. Revision number is not changed for bit locking.



Package Drawing and Dimensions

14 Lead STQFN Package

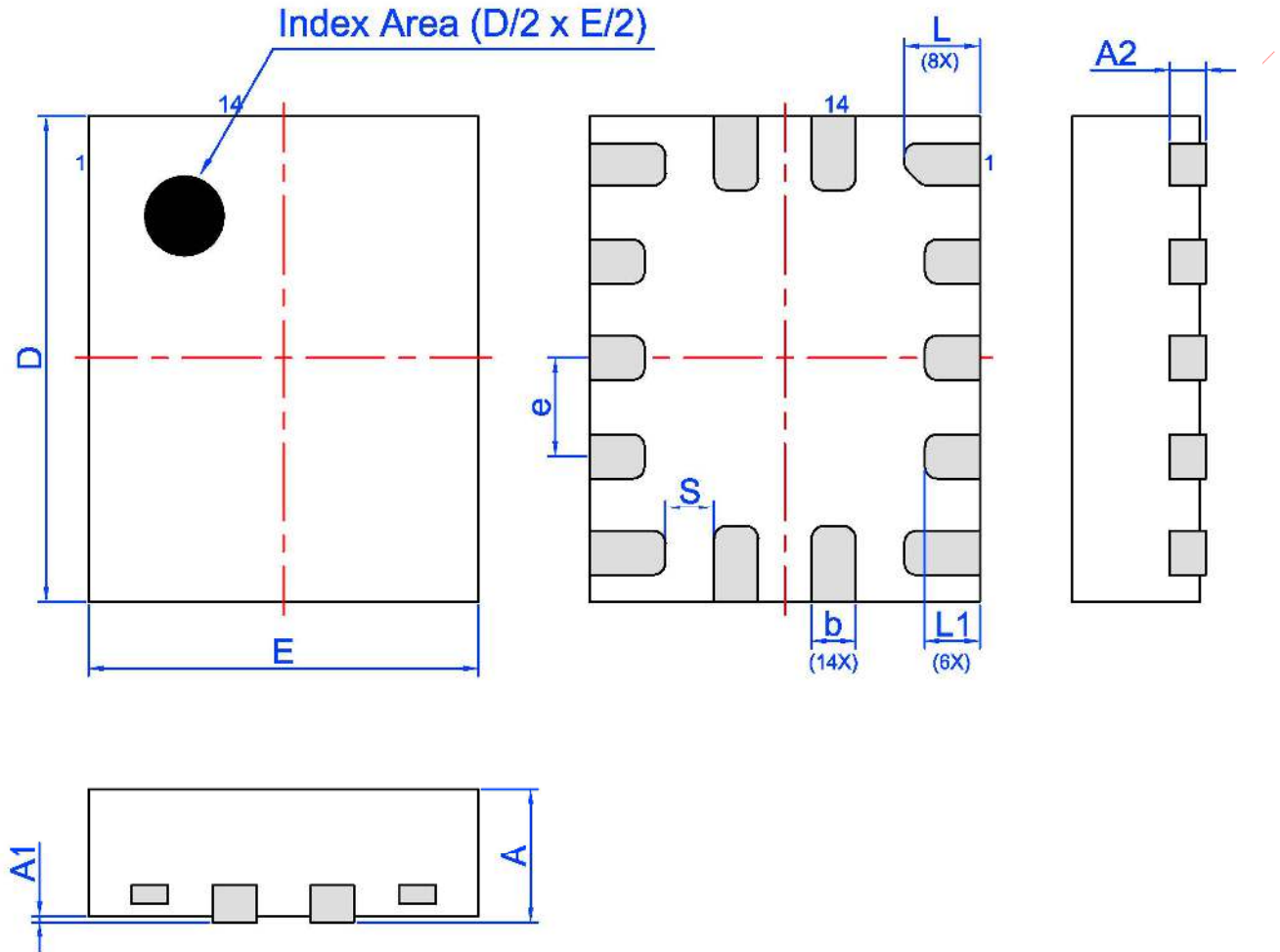

Unit: mm

Symbol	Min	Nom.	Max	Symbol	Min	Nom.	Max
A	0.50	0.55	0.60	D	1.95	2.00	2.05
A1	0.005	-	0.060	E	1.55	1.60	1.65
A2	0.10	0.15	0.20	L	0.26	0.31	0.36
b	0.13	0.18	0.23	L1	0.175	0.225	0.275
e	0.40 BSC			S	0.2 REF		



Tape and Reel Specification

Package Type	# of Pins	Nominal Package Size (mm)	Max Units		Reel & Hub Size (mm)	Trailer A		Leader B		Pocket (mm)	
			per reel	per box		Pockets	Length (mm)	Pockets	Length (mm)	Width	Pitch
STQFN 14L FC 0.4P Green	14	1.6x2.0x0.55	3000	3000	178/60	100	400	100	400	8	4

Carrier Tape Drawing and Dimensions

Package Type	Pocket BTM Length (mm)	Pocket BTM Width (mm)	Pocket Depth (mm)	Index Hole Pitch (mm)	Pocket Pitch (mm)	Index Hole Diameter (mm)	Index Hole to Tape Edge (mm)	Index Hole to Pocket Center (mm)	Tape Width (mm)
	A0	B0	K0	P0	P1	D0	E	F	W
STQFN 14L FC 0.4P Green	1.9	2.3	0.8	4	4	1.5	1.75	3.5	8

Refer to EIA-481 Specifications

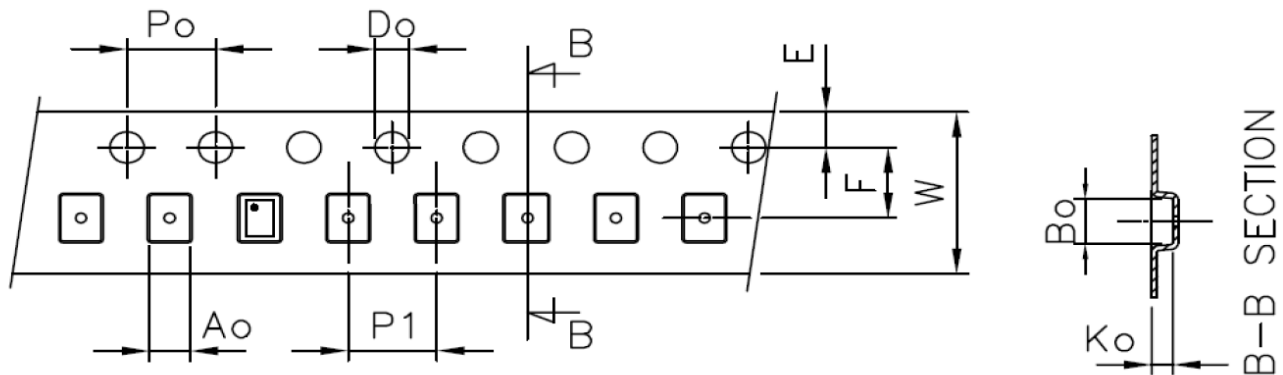

Recommended Reflow Soldering Profile

Please see IPC/JEDEC J-STD-020: latest revision for reflow profile based on package volume of 1.76 mm³ (nominal). More information can be found at www.jedec.org.



Silego Website & Support

Silego Technology Website

Silego Technology provides online support via our website at <http://www.silego.com/>. This website is used as a means to make files and information easily available to customers.

For more information regarding Silego Green products, please visit our website.

Our Green product lines feature:

GreenPAK1 / GreenPAK2 / GreenPAK3/ GreenPAK 4 / GreenPAK 5: Programmable Mixed Signal Matrix products

GreenFET1 / GreenFET3: MOSFET Drivers and ultra-small, low RDSon Load Switches

GreenCLK1 / GreenCLK2 / GreenCLK3: Crystal replacement technology

Products are also available for purchase directly from Silego at the Silego Online Store at <http://www.silego.com/buy/>.

Silego Technical Support

Datasheets and errata, application notes and example designs, user guides, and hardware support documents and the latest software releases are available at the Silego website or can be requested directly at info@silego.com.

For specific GreenPAK design or applications questions and support please send e-mail requests to GreenPAK@silego.com

Users of Silego products can receive assistance through several channels:

Contact Your Local Sales Representative

Customers can contact their local sales representative or field application engineer (FAE) for support. Local sales offices are also available to help customers. More information regarding your local representative is available at the Silego website or send a request to info@silego.com

Contact Silego Directly

Silego can be contacted directly via e-mail at info@silego.com or user submission form, located at the following URL: <http://support.silego.com/>

Other Information

The latest Silego Technology press releases, listing of seminars and events, listings of world wide Silego Technology offices and representatives are all available at <http://www.silego.com/>

THIS PRODUCT HAS BEEN DESIGNED AND QUALIFIED FOR THE CONSUMER MARKET. APPLICATIONS OR USES AS CRITICAL COMPONENTS IN LIFE

SUPPORT DEVICES OR SYSTEMS ARE NOT AUTHORIZED. SILEGO TECHNOLOGY DOES NOT ASSUME ANY LIABILITY ARISING OUT OF SUCH APPLICATIONS OR USES OF ITS PRODUCTS. SILEGO TECHNOLOGY RESERVES THE RIGHT TO IMPROVE PRODUCT DESIGN, FUNCTIONS AND RELIABILITY WITHOUT NOTICE