

A2T

PREMIUM PERFORMANCE SEVERE ENVIRONMENT EMI FILTER

FEATURES

- » **Rated currents include 1A, 2A, 2.2A, 5A, 10A, 12A, 16A and 30A**
- » Multi-Stage Line Filter
- » Available with **QD** (tabs), **S** (studs) and **C** (connectors) option
- » Premium Performance Design
- » End Mount Case Low Profile, Connector & Flange Mount Available
- » Y-cap value can be adjusted to fit specification

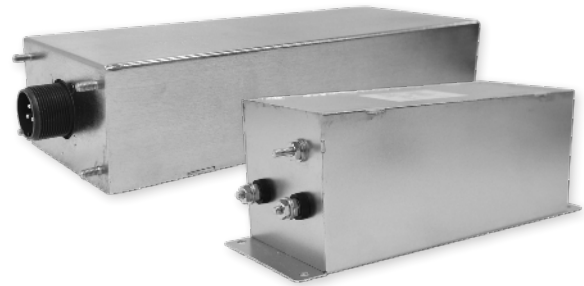

ELECTRICAL SCHEMATIC

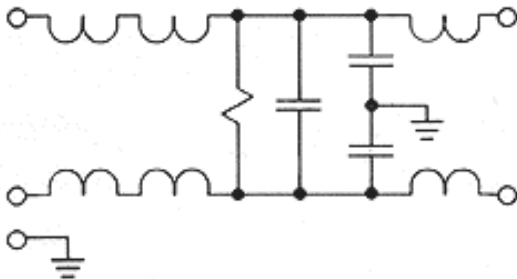

SPECIFICATIONS

OPERATING FREQUENCY 50/60Hz, 50/400Hz
MAX. OPERATING VOLTAGE 250VAC +10%
TERMINALS (-T) QD: 0.25 TABS/
 STUDS: 8-32 (1-5A),
 10-32(10-30A)

TYP. WEIGHT, LBS (KG) 0.61-12.8 (0.27-5.80)

LEAKAGE CURRENT

@ 250 VAC 60 Hz 0 - 3.6 mA Max.

HIPOT RATINGS

LINE TO GROUND 2200 VDC - 2700 VDC

TYPICAL APPLICATIONS

- ✓ High Power Rectifiers
- ✓ Uninterrupted Power Supplies
- ✓ Processing Equipment
- ✓ Alternative Energy (EV Charging & Solar)
- ✓ Factory Machinery

HOW TO ORDER

A2TXX LF

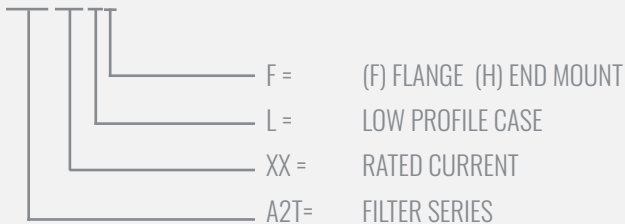

NOTE: USE ANY COMBINATION OF -X (AMPS) WITH ANY -Y RATINGS
 E.G. **A2T10 LF**(10 AMPS, LOW PROFILE CASE, FLANGE MOUNT)

A2T

PREMIUM PERFORMANCE SEVERE ENVIRONMENT EMI FILTER

MODEL NO.	RATED CURRENT (A) @ 40° C	Y-CAP, nF	LEAKAGE CURRENT, mA @ 250V AC, 60 Hz	TERMINAL OPTIONS			MAX. DIMENSIONS" (MM)		
				(QD)INPUT/ OUTPUT	(S) INPUT/ OUTPUT	(C) INPUT/ OUTPUT	WIDTH	(LENGTH)	HEIGHT
A2T1	1	2x.010µF/2x.00033µF	1.8	✓			2.03"	3.7"	1.5"
A2T2	2	*	1.8	*	*	*	*	*	*
A2T2 C	2.5	2x.010µF/2x.00033µF	1.8			✓	2"	6.19"	2"
A2T2 F	2.5	2x.010µF/2x.00033µF	1.8	✓			2"	4.95"	2"
A2T2 FS	2.5	2x.010µF/2x.00033µF	1.8		✓		2"	5.01"	2"
A2T2 L	2.5	2x.010µF/2x.00033µF	1.8		✓		2"	5.01"	2"
A2T2 LG	2.5	2x.010µF/2x.00033µF	1.8		✓		2"	5.01"	2"
A2T2C	2.5	2x.010µF/2x.00033µF	1.8			✓	2"	6.19"	2"
A2T5	5	*	1.8	*	*	*	*	*	*
A2T5 F	5	2x.010µF/2x.001µF	1.8		✓		3"	5.51"	2.75"
A2T5 L	5	2x.010µF/2x.001µF	1.8		✓		2.75"	9.36"	1.75"
A2T5C	5	2x.010µF/2x.001µF	1.8			✓	2.75"	8.65"	1.75"
A2T10 C	10	2x.010µF/2x.00033µF	1.8			✓	3.75"	11.34"	2.25"
A2T10 F	10	2x.010µF/2x.00033µF	1.8		✓		3"	8.26"	3"
A2T10 L	10	2x.010µF/2x.00033µF	1.8		✓		3.75"	11.86"	2.25"
A2T10 LF	10	2x.010µF/2x.00033µF	1.8		✓		4.25"	11.11"	2.25"
A2T10 LH	10	*	1.8		✓		4.25"	11.11"	2.25"
A2T12	12	*	2.4	*	*	*	*	*	*
A2T12 F	12	2x.0022µF/2x.010µF/2x.0022µF	2.4		✓		4"	8.86"	4"
A2T12A F	12	-	3.6		✓		4"	8.86"	4"
A2T16A H	16	2x.0022µF/2x.010µF/2x.010µF	3.6		✓		4"	10.86"	4"
A2T16	16	*	2.4	*	*	*	*	*	*
A2T16 F	16	2x.0022µF/2x.010µF/2x.0022µF	2.4		✓		4"	10.86"	4"
A2T16 L	16	*	2.4	*	*	*	*	*	*
A2T30	30	*	3.5	*	*	*	*	*	*
A2T30 F	30	2x.0022µF/2x.015µF/2x.010µF	3.5		✓		5"	14.86"	4.75"
A2T30 F	30	2x.0022µF/2x.015µF/2x.0022µF	3.5		✓		*	*	*

*Contact factory for part data.

A2T

PREMIUM PERFORMANCE SEVERE ENVIRONMENT EMI FILTER

A2L MECHANICAL OUTLINES

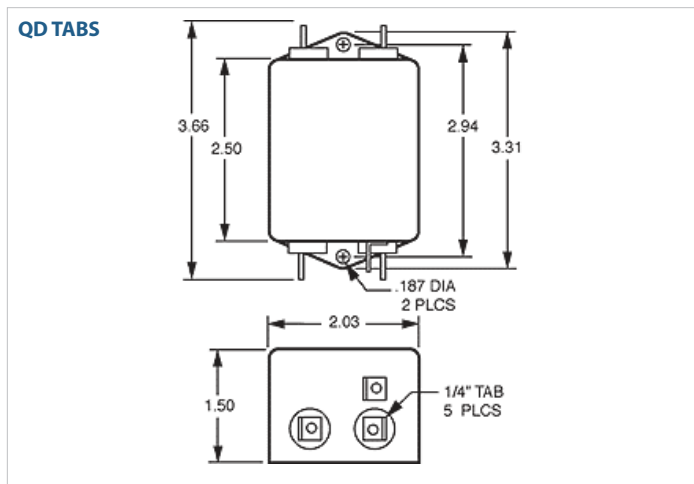

TYPICAL TOLERANCE: +/-0.02" (0.50MM)

TYPICAL INSERTION LOSS, dB (50/50 Ohm)

Amps	Freq (MHz)	0.15	0.5	1.0	10	30
1	CM (dB)	60	60	55	65	70
	DM (dB)	65	*	56	65	69
2	CM (dB)	65	65	55	65	70
	DM (dB)	65	*	56	65	69
2.5	CM (dB)	65	65	55	65	70
	DM (dB)	65	*	56	65	69
5	CM (dB)	65	65	55	65	70
	DM (dB)	65	*	56	65	69
10	CM (dB)	65	65	55	65	70
	DM (dB)	65	*	56	65	69
12	CM (dB)	60	60	55	65	70
	DM (dB)	65	*	56	65	69
16	CM (dB)	65	65	55	65	70
	DM (dB)	65	*	56	65	69
30	CM (dB)	65	65	55	65	70
	DM (dB)	65	*	56	65	69

A2T

PREMIUM PERFORMANCE SEVERE ENVIRONMENT EMI FILTER

A2L MECHANICAL OUTLINES

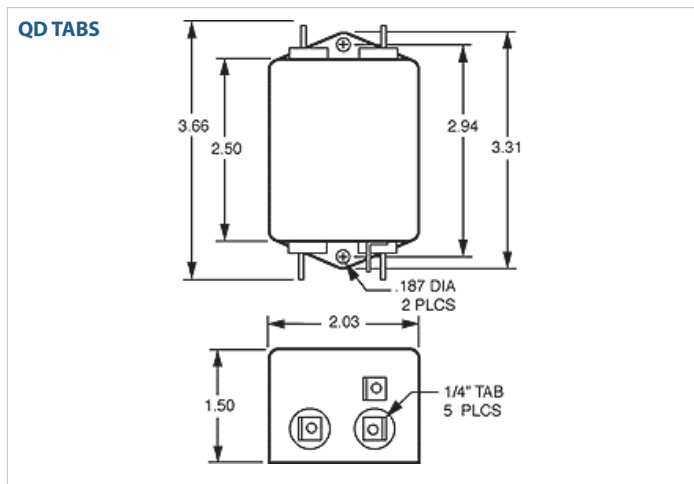

TYPICAL TOLERANCE: +/-0.02" (0.50MM)

TYPICAL INSERTION LOSS, dB (50/50 Ohm)

Amps	Freq (MHz)	0.15	0.5	1.0	10	30
1	CM (dB)	60	60	55	65	70
	DM (dB)	65	*	56	65	69
2	CM (dB)	65	65	55	65	70
	DM (dB)	65	*	56	65	69
2.5	CM (dB)	65	65	55	65	70
	DM (dB)	65	*	56	65	69
5	CM (dB)	65	65	55	65	70
	DM (dB)	65	*	56	65	69
10	CM (dB)	65	65	55	65	70
	DM (dB)	65	*	56	65	69
12	CM (dB)	60	60	55	65	70
	DM (dB)	65	*	56	65	69
16	CM (dB)	65	65	55	65	70
	DM (dB)	65	*	56	65	69
30	CM (dB)	65	65	55	65	70
	DM (dB)	65	*	56	65	69