

- 1 Identification no.**
- 1 For double winged hinges
  - 2 For triple winged hinges, with short middle wing
  - 3 For triple winged hinges, with extended middle wing

**Metric table**

Dimensions in: millimeters - inches

d <sub>1</sub>	d <sub>2</sub>	d <sub>3</sub> ±0.2	d <sub>4</sub>	d <sub>5</sub>	l <sub>1</sub>	l <sub>2</sub>	l <sub>3</sub>	l <sub>4</sub>	l <sub>5</sub>	l <sub>6</sub>	l <sub>7</sub>
6	6.15	13.9	8	7.8	60	50	33	1	20	7.5	1.5
0.24	0.24	0.55	0.31	0.31	2.36	1.97	1.30	0.04	0.79	0.30	0.06

**Specification**

- Bearing bushing / cover cap  
Plastic  
Technopolymer (Polyamide PA)  
Gray, RAL 7024 ● GR
- Tapered dowel pin ISO 8741  
Steel, zinc plated, blue passivated finish
- Plastic Characteristics → page 2135
- RoHS compliant

**Information**

GN 2290 hinge pin sets are designed as components for GN 2291 hinge wings for mounting individual hinge versions.

Hinge pin sets with identification no. 1 are designed for double winged hinges, while hinge pin sets with identification no. 2 and 3 are designed for three winged hinges. Hinge pin sets with identification no. 2 are used exclusively for short middle wings with a length of 40 mm. For extended middle wings, identification no. 3 has to be used.

see also...

- Hinge Wings GN 2291 → page 1354
- Double Winged Hinges GN 2292 (with Positioning Guide) → page 1409
- Double Winged Hinges GN 2294 → page 1410
- Triple Winged Hinges GN 2295 → page 1350

<p>How to order</p> <p><b>GN 2290-1-GR</b></p>	1	Identification no.
	2	Color

**Mounting information**

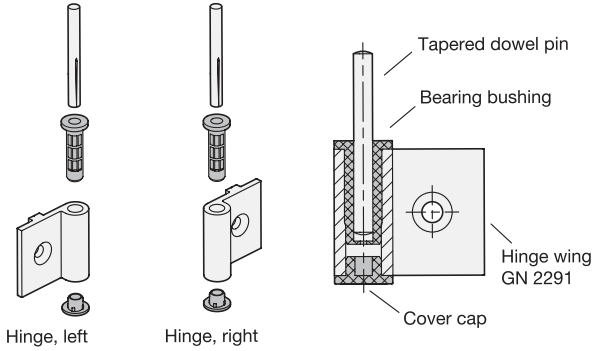

**Left / right hinges**

Right or left hinges can be created by the direction in which the bearing bushings are inserted into the hinge wing.

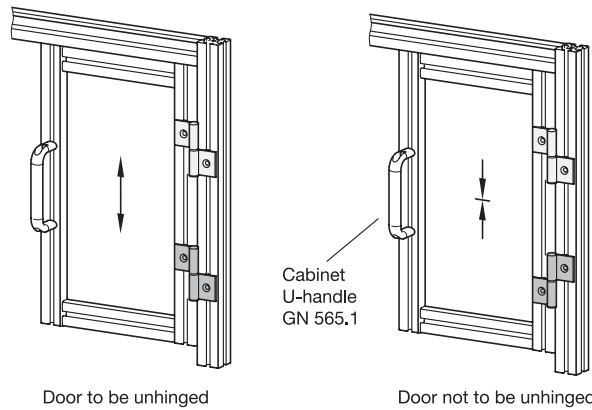

**Mounting on door frames**

For mounting a door that should be removable, two hinges of the same type must be attached to the door frame.

If the door is not supposed to be removable, the door must be mounted with at least one right hinge and one left hinge.

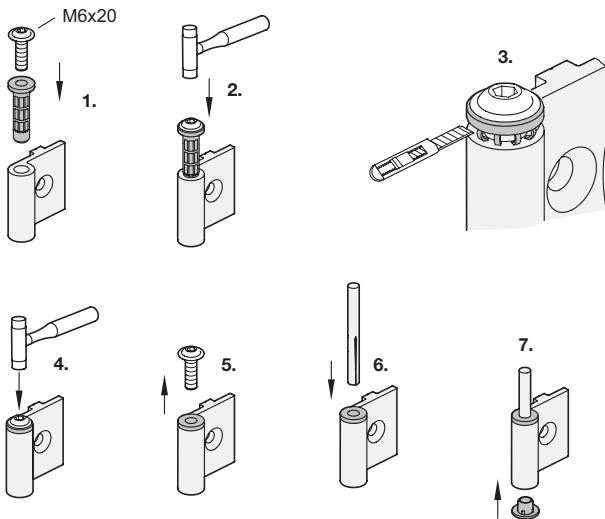

**Assembly**

1. Position the bearing bushing with the desired installation direction on the hinge wing. Then insert a screw with a collar such as an ISO 7380 oval head screw into the bearing bushing to protect the bearing bushing collar from damage while hammering in.

2. Hammer in the bearing bushing until about 1 mm remains between the bearing bushing collar and the hinge wing.

3. Remove the burr on the bearing bushing using a knife.

4. Hammer in the bearing bushing all the way.

5. Remove the screw.

6. Hammer a tapered dowel pin into the bearing bushing.

7. Place the cover cap on the opposite side of the hinge wing.

Insert the other bearing bushings according to points 1 to 5.