



FocusLCDs.com
LCDs MADE SIMPLE®

Ph. 480-503-4295 | NOPP@FocusLCD.com

TFT | CHARACTER | UWVD | FSC | SEGMENT | CUSTOM | REPLACEMENT

TFT Display Module

Part Number

E101RGD1280LBAM350-C

Overview:

- 10.1-inch TFT (229.4x149.1mm)
- Digital Interface
- 1280(RGB)x800 pixels
- 3.3V
- White LED back-light
- Transmissive/ Normally Black
- Capacitive Touch Screen
- 350 NITS
- Controller: FT5826QSL
- RoHS Compliant

1. General Information

Description

This is a color active matrix TFT (Thin Film Transistor) LCD (Liquid Crystal Display) that uses amorphous silicon TFT as a switching device. This model is composed of a transmissive type TFT-LCD Panel, driver circuit, backlight unit and capacitive touch screen. The resolution of the 10.1" TFT-LCD contains 1280x800 pixels and can display up to 262K colors.

Features

Low Input Voltage: 3.3V (TYP)

Display Colors of TFT LCD: 262K colors

TFT Interface: Digital

General Information Items	Specification	Unit	Note
	Main Panel		
TFT Display area (AA)	216.96(W) x 135.60(H) (10.1 inch)	mm	-
Driver element	a-Si TFT active matrix	-	-
Display colors	262K	colors	-
Number of pixels	1280x3(RGB)x800	dots	-
TFT Pixel arrangement	RGB stripe	-	-
Pixel pitch	0.0565 (W) x 0.1695 (H)	mm	-
Viewing angle	ALL	o'clock	-
CTP Driver IC	FT5826QSL	-	-
Display mode	Transmissive/ Normally Black	-	-
Operating temperature	0~+50	°C	-
Storage temperature	-20~+60	°C	-

Mechanical Information

Item		Min	Typ.	Max	Unit	Note
Module size	Height(H)		149.1		mm	-
	Width(W)		229.46		mm	-
	Depth(D)		2.50		mm	-
Weight			TBD		g	-

2. Outline Dimensions

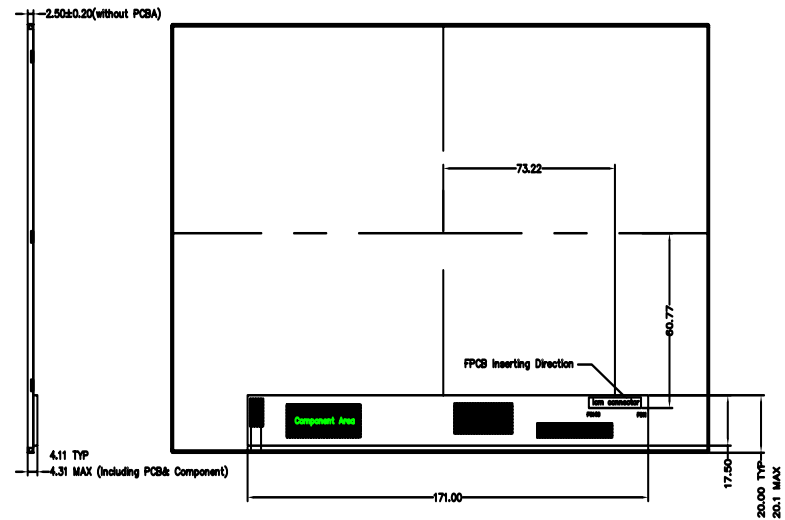
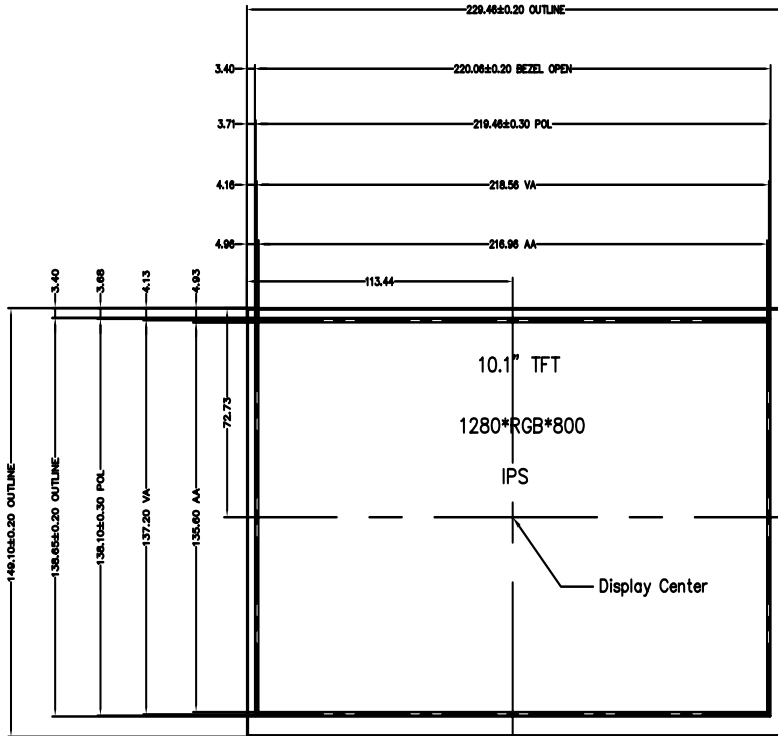

NO.	Pin Name
1	VCOM
2	VDD
3	VDD
4	NC
5	NC
6	NC
7	GND
8	RXIN0-
9	RXIN0+
10	GND
11	RXIN1-
12	RXIN1+
13	GND
14	RXIN2-
15	RXIN2+
16	GND
17	RXCLK-
18	RXCLK+
19	GND
20	RXIN3-
21	RXIN3+
22	GND
23	NC
24	NC
25	GND
26	NC
27	LED_PWM
28	NC
29	AVDD
30	GND
31	LED-
32	LED-
33	NC
34	NC
35	VGL
36	NC
37	CABC_EN
38	VGH
39	LED+
40	LED+

NOTES:

- Unit: mm
- Luminance: 350cd/m²
- Operation Temp: 0°C to 50°C
Storage Temp: -20°C to 60°C
- General Tolerance ±0.30mm
- The LCM Connector is F62240-H1210A
- ROHS Compliant

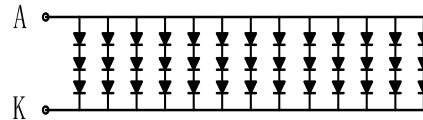

B/L Circuit (If=260mA, Vf=9.3V)

Rev	Revision content description	Date	TOLERANCE		
A	FIRST	2014/04/07	TOLERANCE UNLESS OTHERWISE SPECIFIED	X.X±0.3	
				X.XX±0.2	

Scale 1:1 Approve Page 1/1



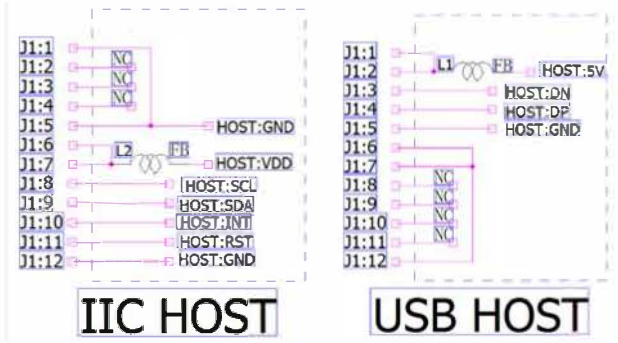
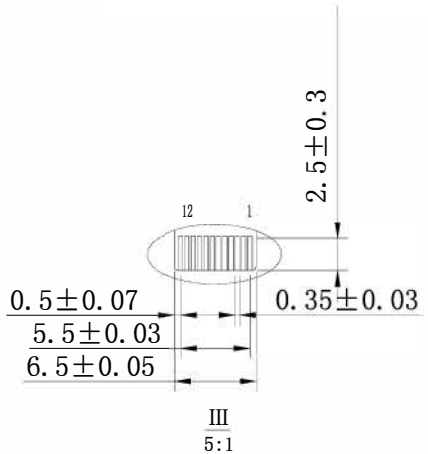
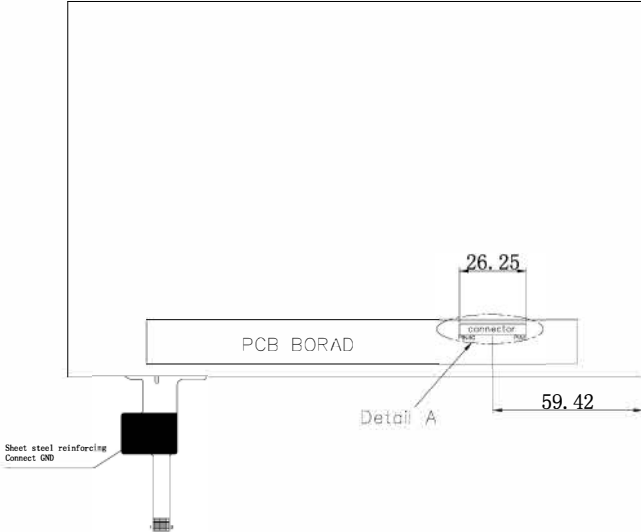
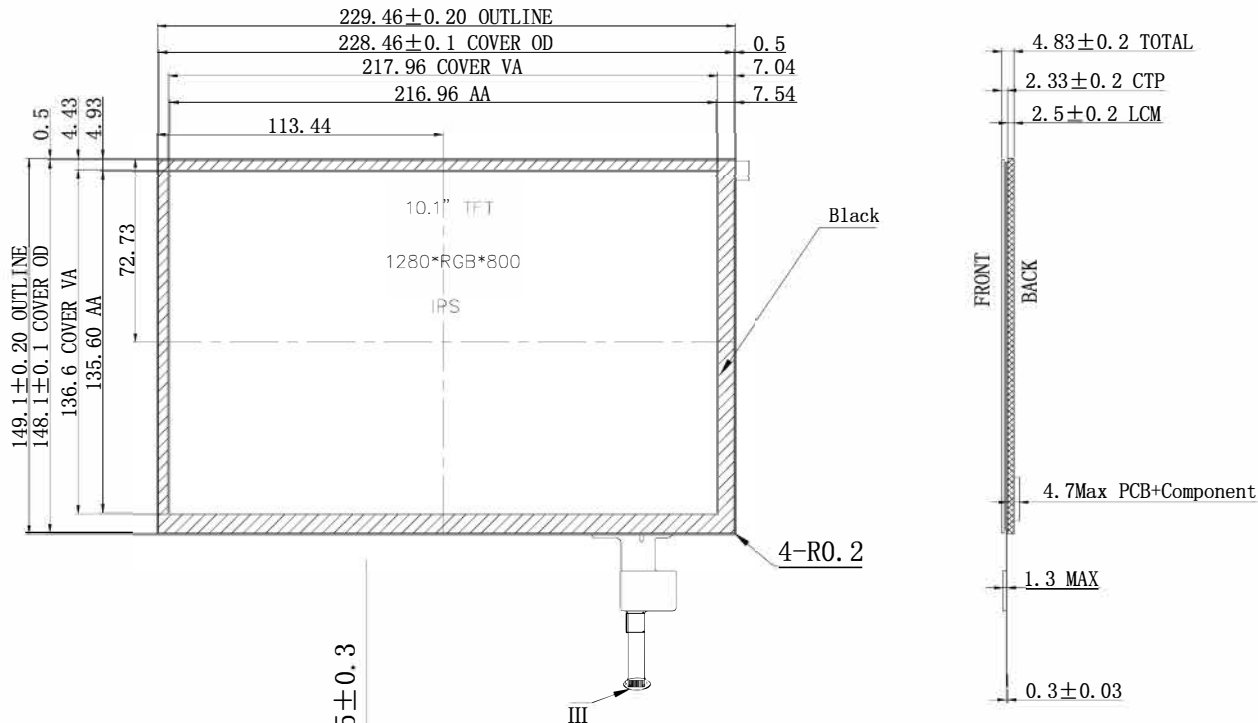

NO.	Pin Name
1	VCOM
2	VDD
3	VDD
4	NC
5	NC
6	NC
7	GND
8	RXIN0-
9	RXIN0+
10	GND
11	RXIN1-
12	RXIN1+
13	GND
14	RXIN2-
15	RXIN2+
16	GND
17	RXCLK-
18	RXCLK+
19	GND
20	RXIN3
21	RXIN3+
22	GND
23	NC
24	NC
25	GND
26	NC
27	LED_PV
28	NC
29	AVDD
30	GND
31	LED-
32	LED-
33	NC
34	NC
35	VGL
36	NC
37	CABC_E
38	VGH
39	VLED+
40	VLED+

NOTES:

1. DISPLAY TYPE: 10.1", TFT-LCD, 262K COLORS
2. DISPLAY MODE: NORMALLY BLACK
3. VIEWING DIRECTION: ALL
4. CTP DRIVER IC: FT5826QSL
5. VDD: 3.3V
6. CTP SURFACE HARDNESS: 6H
7. OPERATING TEMP: 0°C TO 50°C
STORAGE TEMP: -20°C TO 60°C
8. RoHS COMPLIANT.

A magnetic bead has to be added to the host for the FPC to work in coexistence mode.

1. To work in USB mode, the connection is as below. NC unconnected. Magnetic bead L1 should be connected to USB_5V.(J1 is one of the pins of FPC)
2. To work in IIC mode, the connection is as below. NC unconnected. Magnetic bead L2 should be connected to VDD.(J1 is one of the pins of FPC)

ReV	Revision content description	Date
A	FIRST	2016/06/03



FocusLCDs.com
LCDs MADE SIMPLE®

TOLERANCE ()		DRAWING NAME	
PARTS NO.		PARTS NO.	
TOLERANCE UNLESS OTHERWISE SPECIFIED	X.XX+0.3	Drawn	Unit
	X.XX+0.2	Checked	mm
Scale 1:1		Approve	Page 1/1

3. Input Terminal Pin Assignment

NO.	Symbol	Description	I/O
1	VCOM	Common voltage	P
2	VDD	Power supply	P
3	VDD	Power supply	P
4	NC	No connection	--
5	NC	No connection	--
6	NC	No connection	--
7	GND	Ground	P
8	Rxin0-	-LVDS differential data input (R0-R5, G0)	I
9	Rxin0+	+LVDS differential data input (R0-R5, G0)	I
10	GND	Ground	P
11	Rxin1-	-LVDS differential data input (G1-G5, B0, B1)	I
12	Rxin1+	+LVDS differential data input (G1-G5, B0, B1)	I
13	GND	Ground	P
14	Rxin2-	-LVDS differential data input (B2-B5, HS, VS, DE)	I
15	Rxin2+	+LVDS differential data input (B2-B5, HS, VS, DE)	I
16	GND	Ground	P
17	RxCLK-	-LVDS differential clock input (LVDS CLK)	I
18	RxCLK+	+LVDS differential clock input (LVDS CLK)	I
19	GND	Ground	P
20	Rxin3-	-LVDS differential data input (R6, R7, G6, G7, B6, B7)	I
21	Rxin3+	+LVDS differential data input (R6, R7, G6, G7, B6, B7)	I
22	GND	Ground	P
23	NC	No connection	--
24	NC	No connection	--
25	GND	Ground	P
26	NC	No connection	--
27	LED_PWM	CABC controller signal output for backlight. Used to adjust backlight brightness.	O
28	NC	No connection	--
29	AVDD	Power for analog circuit	P
30	GND	Ground	P
31	LED-	LED cathode	P
32	LED-	LED cathode	P
33	NC	No connection	--
34	NC	No connection	--
35	VGL	Gate off voltage	P
36	NC	No connection	--
37	CABC_EN	CABC enable input. Enabled high. Low voltage or open to disable.	I
38	VGH	Gate on voltage	P
39	LED+	LED anode	P
40	LED+	LED anode	P

I: Input, O: Output, P: Power

4. LCD Optical Characteristics

4.1 Optical Specifications

Item	Symbol	Condition	Min	Typ.	Max	Unit	Note	
Contrast Ratio	CR	$\Theta = \phi = 0$ Normal viewing angle	600	800	--	--	(2)	
Luminance	L		300	350	400	cd/m ²	(3)	
Response time	Rising		T _R	--	10	20	msec	(4)
	Falling		T _F	--	15	30		
Uniformity	Y _u		70	75	--	%	(5)	
Color Filter Chromaticity	White		W _X	0.26	0.31	0.36	(5)(6)	
		W _Y	0.28	0.33	0.38			
Viewing angle	Hor.	Θ_L	$\phi=180^\circ$ (9 o'clock)	75	85	--	degree	(1)(6)
		Θ_R	$\phi=0^\circ$ (3 o'clock)	75	85	--		
	Ver.	Θ_T	$\phi=90^\circ$ (12 o'clock)	75	85	--		
		Θ_B	$\phi=270^\circ$ (6 o'clock)	75	85	--		
Option View Direction	ALL						(1)	

4.2 Measuring Condition

VDD = 3.3V, IL = 260mA (Backlight current)

Ambient temperature: 25 ± 2°C

15min. warm-up time

Optical Specification Reference Notes:

(1) Definition of Viewing Angle: The viewing angle is the angle at which the contrast ratio is greater than 10. The viewing angles are determined for the horizontal or 3,9 o'clock direction and the vertical or 6,12 o'clock direction with respect to the optical axis which is normal to the LCD surface.

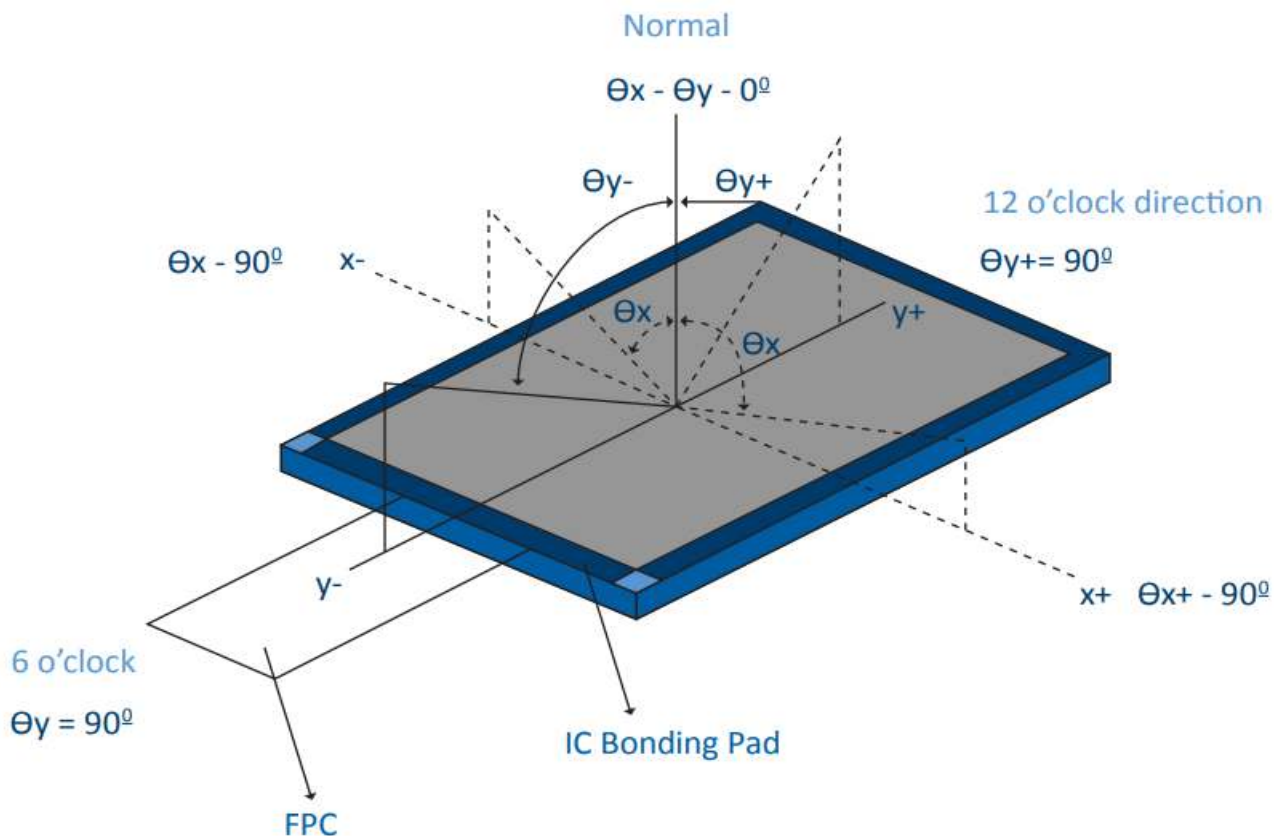
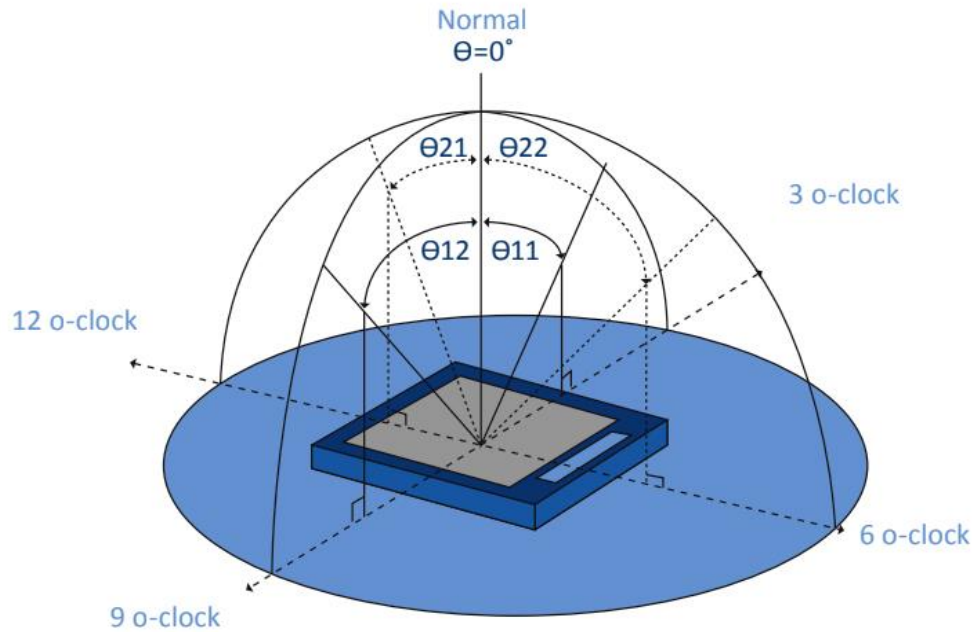

(2) Definition of Contrast Ratio (Cr): measured at the center point of panel. The contrast ratio (Cr) measured on a module, is the ratio between the luminance (Lw) in a full white area (R=G=B=1) and the luminance (Ld) in a dark area (R=G=B=0).

$$Cr = \frac{L_w}{L_d}$$

(3) Definition of transmittance (T%): The transmittance of the panel including the polarizers is measured with electrical driving.

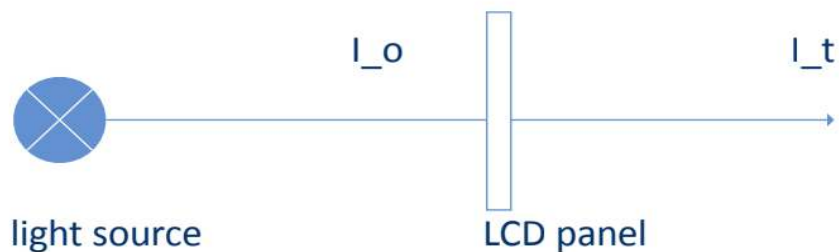

The transmittance is defined as:

$$Tr = \frac{I_t}{I_o} \times 100\%$$

I_o = the brightness of the light source.

I_t = the brightness after panel transmission

(4) Definition of Response Time (T_r , T_f): The rise time ' T_r ' is defined as the time for luminance to change from 90% to 10% as a result of a change of the electrical condition. The fall time ' T_f ' is defined as the time for luminance to change from 10% to 90% as a result of a change of the electrical condition.

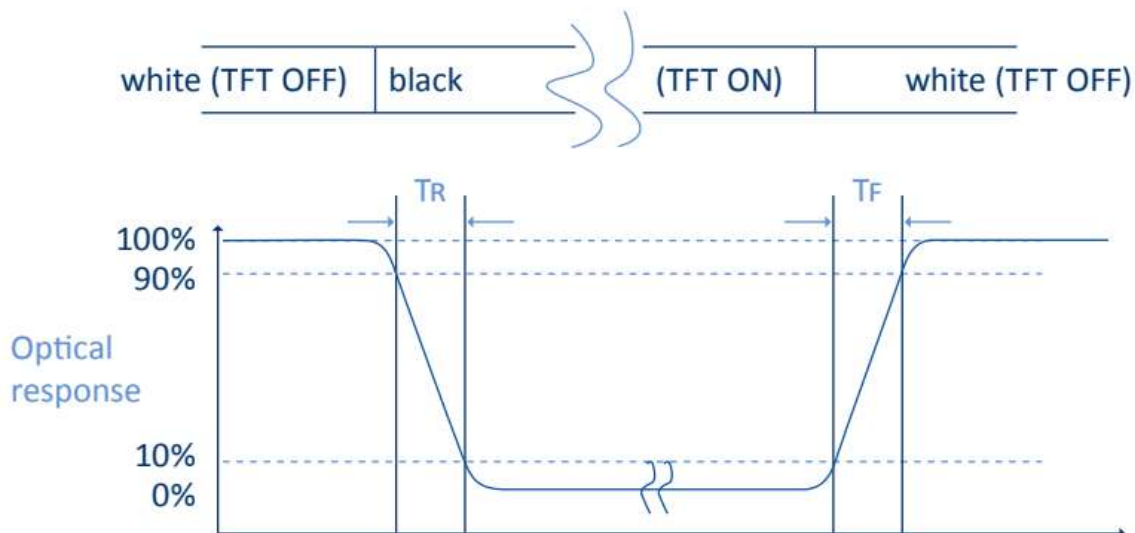

(5) Definition of Color Gamut: Measuring machine CFT-01. NTSC's Primaries: R(x,y,Y),G(x,y,Y), B(x,y,Y). FPM520 of Westar Display Technologies, INC., which utilized SR-3 for Chromaticity and BM-5A for other optical characteristics. The color chromaticity shall be calculated from the spectral data measured with all pixels first in red, green, blue and white. Measurements shall be made at the center of the panel.

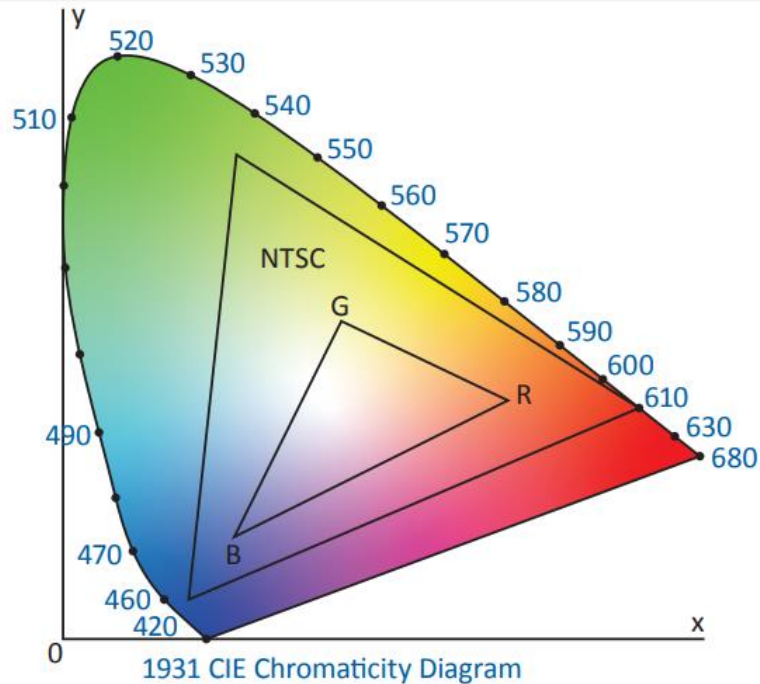
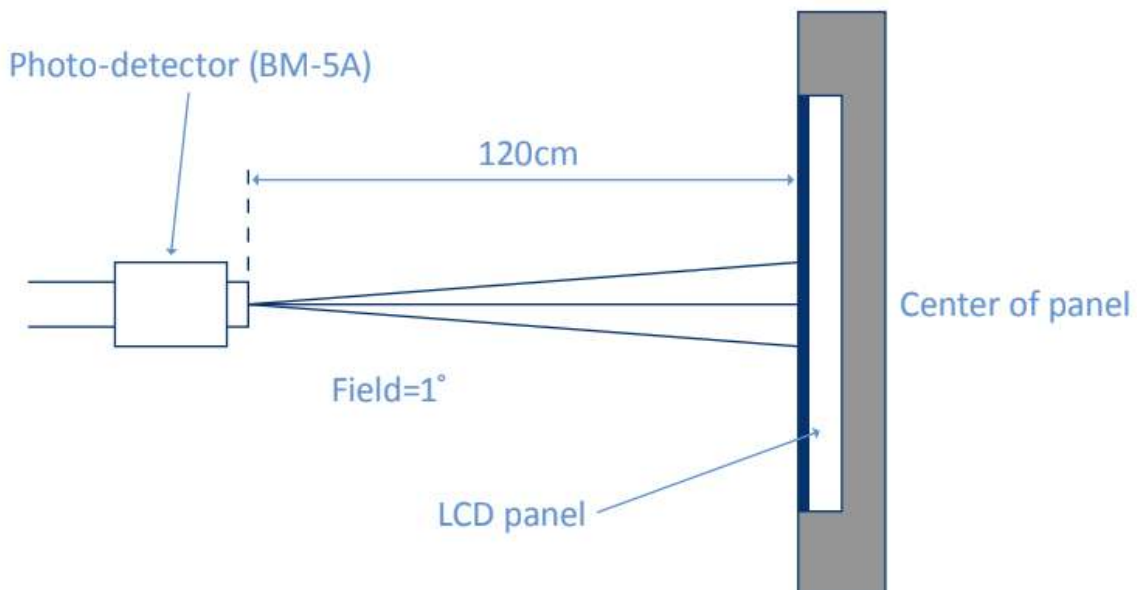

Fig. 1931 CIE chromacity diagram

$$\text{Color gamut: } S = \frac{\text{Area of RGB triangle}}{\text{Area of NTSC triangle}} \times 100\%$$

(6) Definition of Optical Measurement Setup:



(6) Optical Measurement Setup Continued:

The LCD module should be stabilized at a given temperature for 20 minutes to avoid abrupt temperature change during measuring. In order to stabilize the luminance, the measurement should be executed after lighting backlight for 20 minutes.

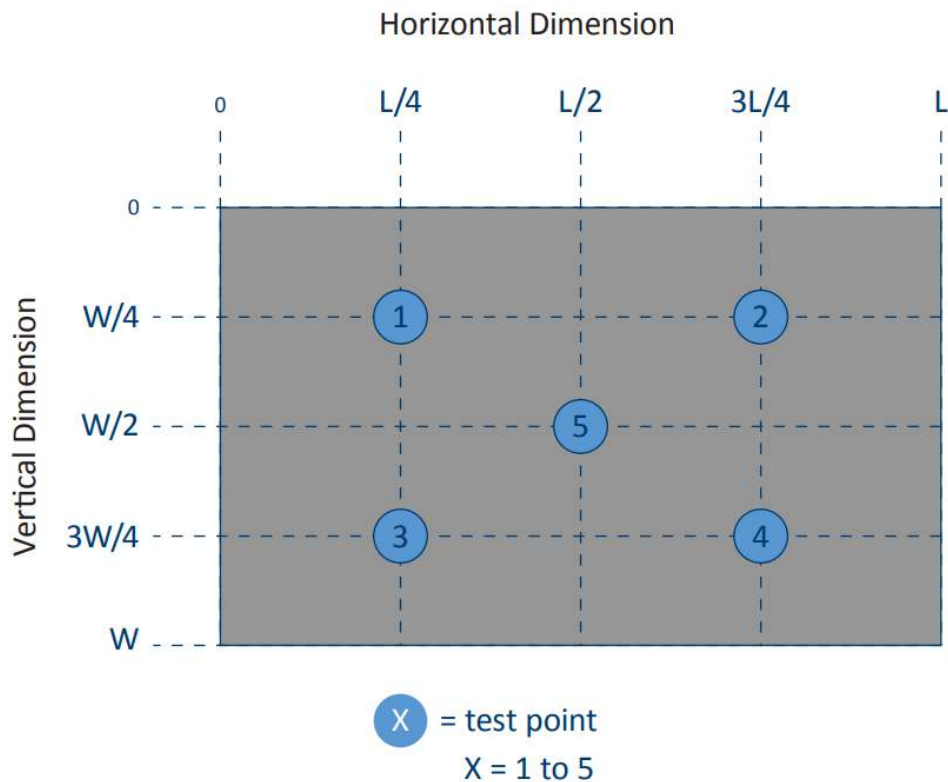
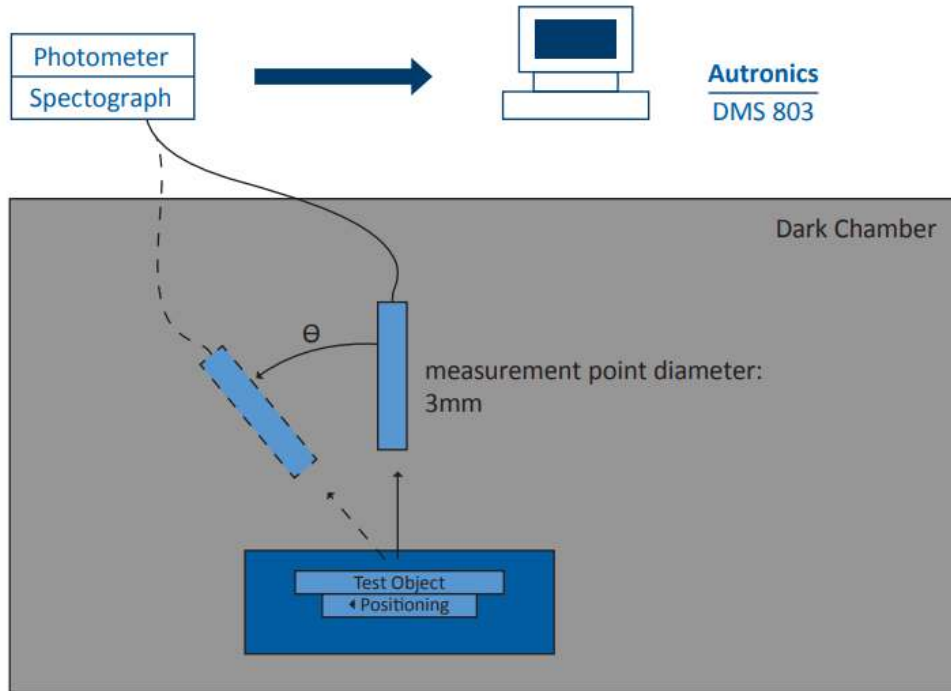

5. Electrical Characteristics

5.1 Absolute Maximum Rating (Ta=25 °C, VSS=0V)

Characteristics	Symbol	Min	Max	Unit
Power Voltage	VDD	-0.3	3.9	V
	AVDD	-0.3	14	V
	VGH	-0.3	42.0	V
	VGL	-19	0.3	V
	VGH-VGL	12	40.0	V
Operating Temperature	TOP	0	+50	°C
Storage Temperature	TST	-20	+60	°C

If the absolute maximum rating of even is one of the above parameters is exceeded even momentarily, the quality of the product may be degraded. Absolute maximum ratings, therefore, specify the values exceeding which the product may be physically damaged. Be sure to use the product within the range of the absolute maximum ratings.

5.2 Typical Operating Conditions

Characteristics	Symbol	Min	Typ.	Max	Unit	Note
Power Voltage	VDD	2.3	2.5	2.7	V	(1)
	AVDD	8.0	8.2	8.4	V	
	VGH	21.7	22	22.3	V	(2)
	VGL	-7.3	-7	-6.7	V	
Input Logic High Voltage	VIH	0.8VDD	--	VDD	V	
Input Logic Low Voltage	VIL	0	--	0.2DVDD	V	
Input Signal Voltage	VCOM	3.0	3.3	3.6	V	(3)

Note 1.) Be sure to apply VDD and VGL to the LCD first, then apply VGH.

Note 2.) VDD setting should match the signals output voltage of the system board.

Note 3.) Typical VCOM is only a reference value, it must be optimized according to each LCM. Be sure to use VR.

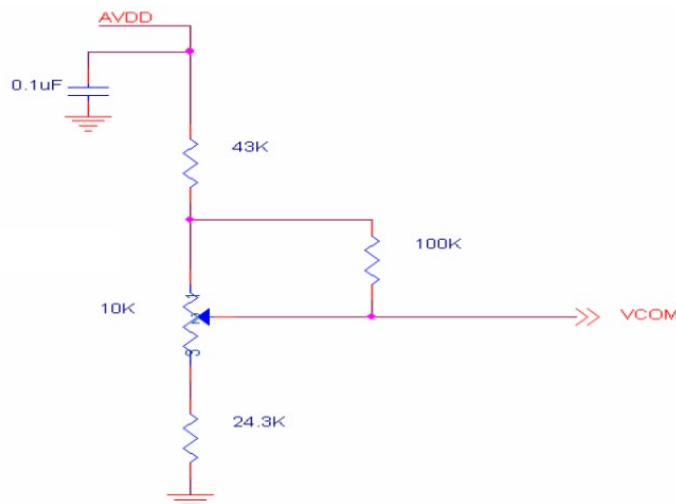

5.3 LED Backlight Characteristics

The backlight system is edge lighting type with 39 chips LED.

Item	Symbol	Min	Typ.	Max	Unit	Note
Backlight Current	IL	--	260	--	mA	
Backlight Voltage	VL	8.7	9.3	9.9	V	
LCM Luminance	LV	--	350	--	cd/m ²	Note 3
LED lifetime	Hr	15000	20000	--	hour	Note1 & 2
Uniformity	AVg	80	--	--	%	Note 3

Note 1: LED lifetime (Hr) can be defined as the time in which it continues to operate under the condition: Ta=25 ±3 °C, typical IL value indicated in the above table until the brightness becomes less than 50%.

Note 2: The “LED lifetime” is defined as the module brightness decrease to 50% original brightness at Ta=25°C and IL = 260mA. The LED lifetime could be decreased if operating IL is larger than 260mA. The constant current driving method is suggested.

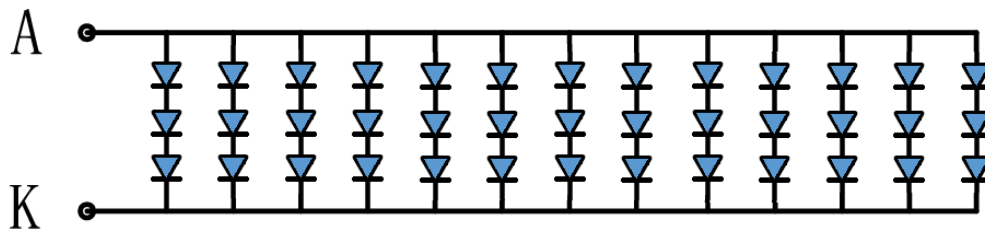

Backlight Circuit (IF=260mA, VF=9.3V)

Note 3: Luminance Uniformity of these 9 points is defined as below:

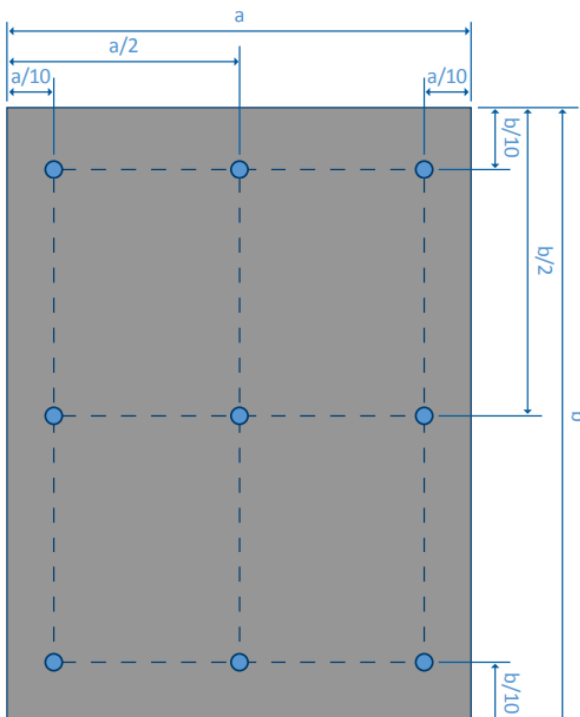

$$\text{Luminance} = \frac{\text{Total Luminance of 9 points}}{9}$$

$$\text{Uniformity} = \frac{\text{minimum luminance in 9 points(1-9)}}{\text{maximum luminance in 9 points(1-9)}}$$

6. Timing Characteristics

6.1 AC Electrical Characteristics

Parameter	Symbol	Min	Typ.	Max	Unit	Note
LVDS differential input high threshold voltage	R_{xVTH}	--	--	+100	mV	$R_{xVCM}=1.2V$
LVDS differential input low threshold voltage	R_{xVTL}	-100	--	--	mV	
LVDS differential input common mode voltage	R_{xVCM}	0.7	--	1.6	V	
LVDS differential voltage	$ V_{ID} $	100	--	600	mV	

Table 6.1: AC Electrical Differential Input Timing Characteristics

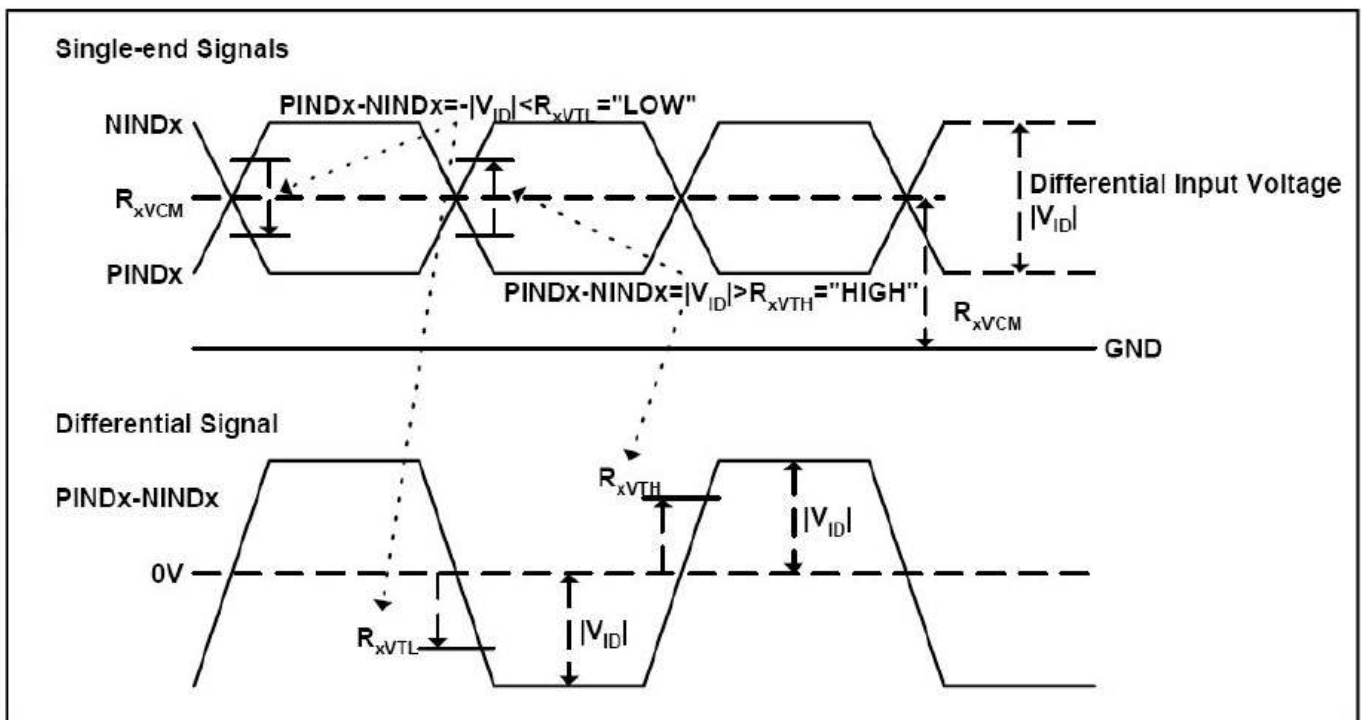

Figure 6.1: Differential and Single-End Input Timing Diagram

6.2 Clock and Data Timing Characteristics

Parameter	Symbol	Min	Typ.	Max	Unit	Note
Clock frequency	$1/T_c$	68.9	71.1	73.4	MHz	
Horizontal display area	t_{HD}	1280	1280	1280	Tc	
HS period time	t_H	1410	1440	1470	Tc	
HS width + Back porch + Front porch	$t_{HW}+t_{HBP}+t_{HFP}$	60	160	190	Tc	
Vertical display area	t_{VD}	800	800	800	tH	
VS period time	t_V	815	823	833	tH	
VS width + Back porch + Front porch	$t_{VW}+t_{VBP}+t_{VFP}$	15	23	33	tH	

Table 6.2: Horizontal and Vertical Data Timing Characteristics

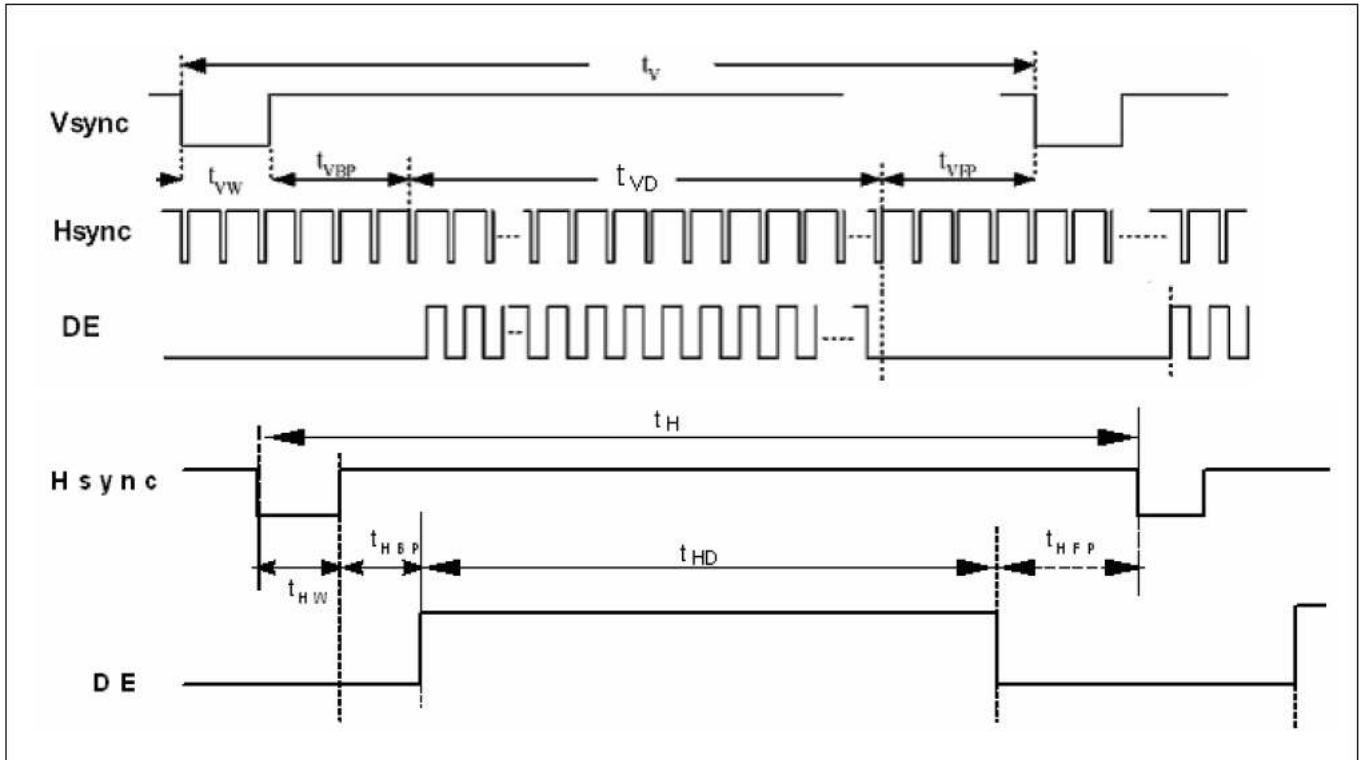

Figure 6.2: Vertical and Horizontal Sync Data Input Timing Diagram

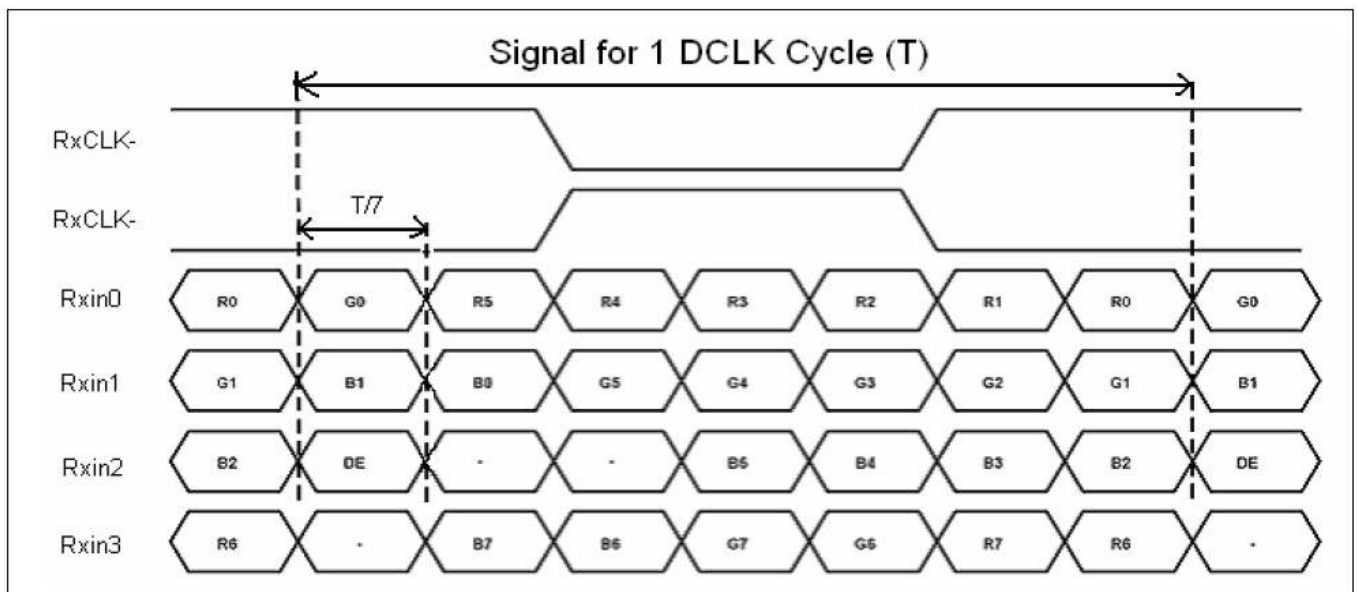

Figure 6.3: LVDS Data Input Timing Diagram

6.3 Power Sequence Timing Diagrams

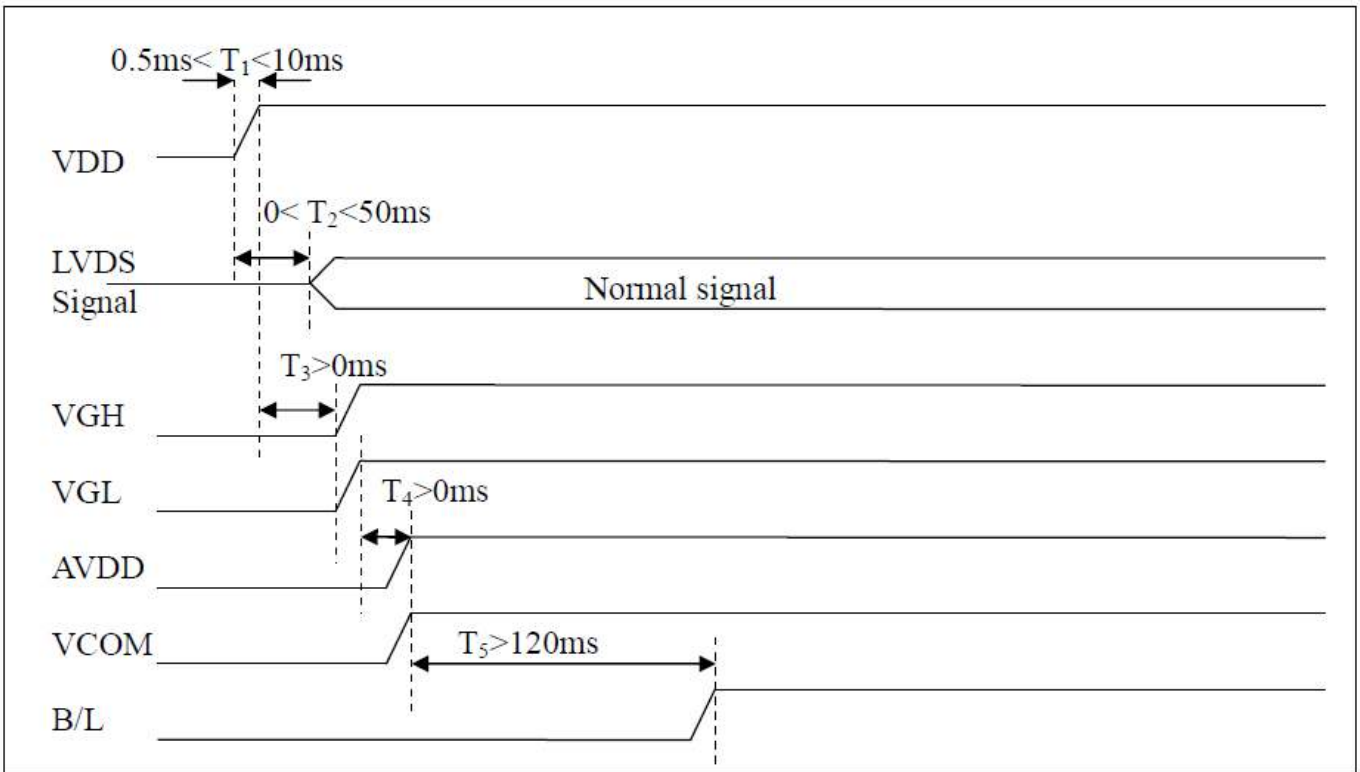

Figure 6.4: Power On Sequence Timing Diagram

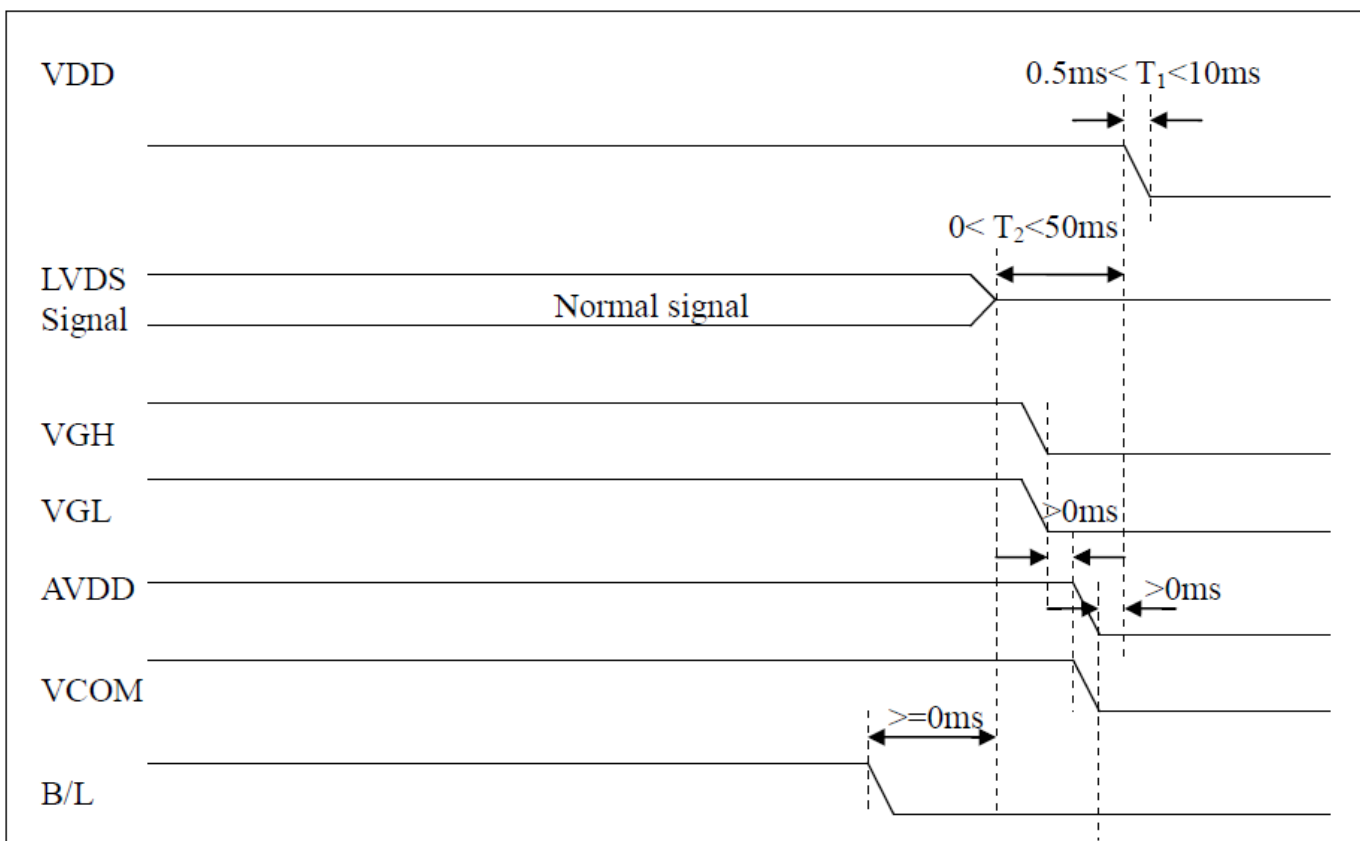

Figure 6.5: Power Off Sequence Timing Diagram

7. Cautions and Handling Precautions

7.1 Handling and Operating the Module

1. When the module is assembled, it should be attached to the system firmly. Do not warp or twist the module during assembly work.
2. Protect the module from physical shock or any force. In addition to damage, this may cause improper operation or damage to the module and back-light unit.
3. Note that polarizer is very fragile and could be easily damaged. Do not press or scratch the surface.
4. Do not allow drops of water or chemicals to remain on the display surface. If you have the droplets for a long time, staining and discoloration may occur.
5. If the surface of the polarizer is dirty, clean it using some absorbent cotton or soft cloth.
6. The desirable cleaners are water, IPA (Isopropyl Alcohol) or Hexane. Do not use ketene type materials (ex. Acetone), Ethyl alcohol, Toluene, Ethyl acid or Methyl chloride. It might permanent damage to the polarizer due to chemical reaction.
7. If the liquid crystal material leaks from the panel, it should be kept away from the eyes or mouth. In case of contact with hands, legs, or clothes, it must be washed away thoroughly with soap.
8. Protect the module from static; it may cause damage to the CMOSICs.
9. Use fingerstalls with soft gloves in order to keep display clean during the incoming inspection and assembly process.
10. Do not disassemble the module.
11. Protection film for polarizer on the module shall be slowly peeled off just before use so that the electrostatic charge can be minimized.
12. Pins of I/F connector shall not be touched directly with bare hands.
13. Do not connect, disconnect the module in the "Power ON" condition.
14. Power supply should always be turned on/off by the item Power On Sequence & Power Off Sequence.

7.2 Storage and Transportation.

1. Do not leave the panel in high temperature, and high humidity for a long time. It is highly recommended to store the module with temperature from 0 to 35 °C and relative humidity of less than 70%
2. Do not store the TFT-LCD module in direct sunlight.
3. The module shall be stored in a dark place. When storing the modules for a long time, be sure to adopt effective measures for protecting the modules from strong ultraviolet radiation, sunlight, or fluorescent light.
4. It is recommended that the modules should be stored under a condition where no condensation is allowed. Formation of dewdrops may cause an abnormal operation or a failure of the module. In particular, the greatest possible care should be taken to prevent any module from being operated where condensation has occurred inside.
5. This panel has its circuitry FPC on the bottom side and should be handled carefully in order not to be stressed.