

used for: D-SUB FILTER

POS.	A <sup>-0.76</sup>	B <sup>-0.25</sup>	C	Part NO.
9	31.19	16.46	25.00 <sup>+0.12</sup> / <sub>-0.13</sub>	<b>242A10690X</b>
15	39.52	24.79	33.30 <sup>+0.15</sup> / <sub>-0.1</sub>	<b>242A10700X</b>
25	53.42	38.50	47.04 $\pm 0.13$	<b>242A10710X</b>
37	69.70	54.96	63.50 $\pm 0.13$	<b>242A10720X</b>

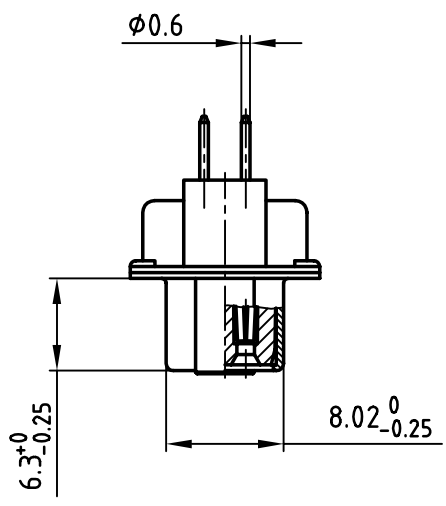
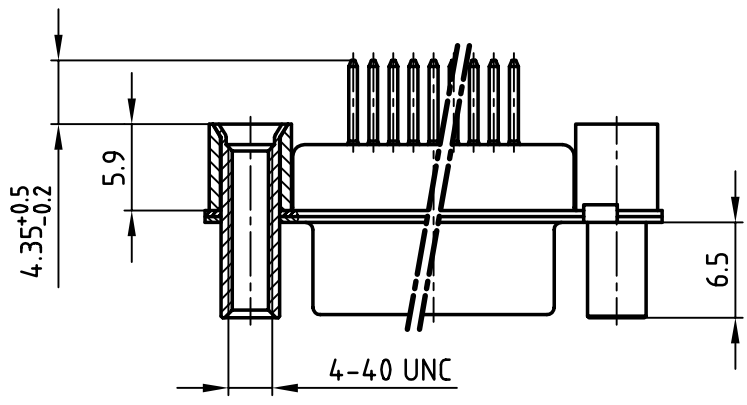
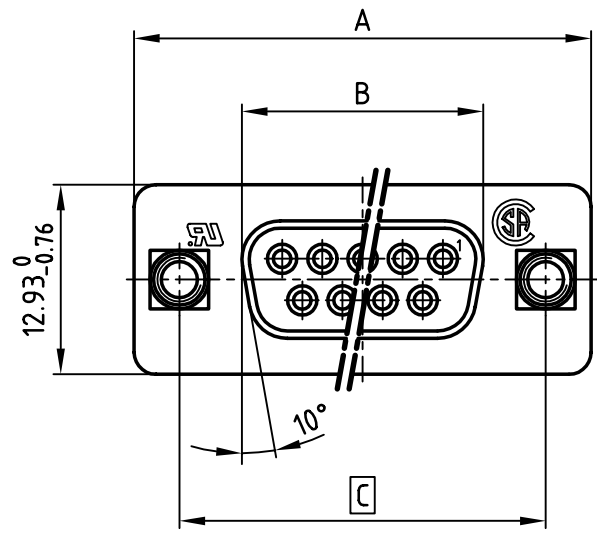

**NOTES:**

1. METALSHELLS: STEEL; min. 320 $\mu$ " TIN
2. INSULATORS: PBT GF UL 94 V-0, BLACK
3. CONTACTS: COPPER ALLOY
4. PLATING: min. 8 $\mu$ " HARD GOLD OVER min. 50 $\mu$ " NICKEL
5. THREADED REAR SPACER: COPPER ALLOY; min. 200 $\mu$ " TIN over 80 $\mu$ " NICKEL
6. FRONT THREADED LOCK: COPPER ALLOY; min. 200 $\mu$ " TIN over 80 $\mu$ " NICKEL
7. P.C.B. HOLE DRILLINGS ON DRAWING NO.: 16K111UA
8. CAPACITANCE: 830pF  $\pm 20\%$
9. MAXIMUM TORQUE VALUE FOR THREAD: 6" LBS
10.  = CRITICAL DIMENSION: SPC

THIS DRAWING MAY NOT BE COPIED OR REPRODUCED IN ANY WAY, AND MAY NOT BE PASSED ON TO A THIRD PARTY WITHOUT WRITTEN PERMISSION.  
 OWNERSHIP AND COPYRIGHT OF CONEC GmbH  
 DO NOT ALTER CAD DRAWING BY HAND

CONEC CORPORATION BRAMPTON, ONTARIO		
rev.	description	date

tolerance		
2002	date	name
drawn	29.01.	Parei
appd.	30.01.	E. Mickenbecker
norm	DIN 41652	
d-old		

scale:	2:1
material:	SEE NOTES
title:	<b>D-SUB FILTER FEMALE</b> 9-37pos. SOLDER PIN STRAIGHT threaded rear spacer and front threaded lock
dwg no:	AutoCAD 2000
part no:	SEE TABLE
DIN-A	4
sh:	1/1

